

# NGX<sup>®</sup>

## MINI 2



## Installation & Owner's Manual

With 1000 Watt Amplifier



U.S. and Canada; call toll-free:  
1-877-ROC\_N\_ROL (1-877-762-6765)

E-Mail: [support@amientertainment.com](mailto:support@amientertainment.com) Web: [www.amientertainment.com](http://www.amientertainment.com)

Outside the U.S. and Canada; call:  
+1 (616) 243-3633  
22022623 Rev B

## AMI NGX MINI 2 JUKEBOX WARRANTY

AMI extends the original operator of this equipment the following warranty:

All parts are guaranteed to be free of defects in material and workmanship for the specific periods listed. AMI agrees to repair or replace without charge during such period any part which proves defective upon examination by AMI. All costs of shipping a defective part to AMI's offices shall be borne by the original operator. AMI shall bear the shipping costs for the replacement of defective parts.

<u>Component</u>	<u>Warranty Period</u> (from date of shipment)	<u>Condition</u>
Electronic Circuit Boards	2 Years	Parts
Core Computer Motherboard	1 Year	Parts
Electrical & Mechanical	2 Years	Parts
LCD Display	1 Year	Parts
Touch Screen Sensor	1 Year	Parts
Touch Screen Controller	1 Year	Parts
Hard Drives	Life*	*Full Replacement by AMI, at no charge, for the life of the AMI Entertainment® contract.

In the case of parts supplied to AMI as components, AMI extends the same warranty period as extended by the original manufacturer.

The above warranty applies provided that all parts of the product have been serviced properly as directed in the service manual, and provided the alleged defective part, upon examination by AMI, shall prove to be thus defective. Under no circumstances shall AMI be liable for any incidental, consequential or special damages, losses or expenses arising from or in connection with the use of, or the inability to use, the product for any purpose. AMI reserves the right to make any changes or improvements in its products without notice and obligation, and without being required to make corresponding changes or improvements in products theretofore manufactured or sold.

This warranty will not apply to any product or any part which has been subjected to any accident, abuse, or misuse.

**AMI ENTERTAINMENT NETWORK, LLC EXTENDS NO WARRANTY, EXPRESSED OR IMPLIED, TO PURCHASERS OR USERS OF ITS PRODUCTS EXCEPT AS HEREIN SET FORTH, WHETHER BY OPERATION OF LAW OR OTHERWISE.**

## Table of Contents

---

<b>Important Safety Instructions</b>	<b>2</b>
<b>Section A - Jukebox Specifications</b>	<b>3</b>
<b>Section B - Placing the Wall-Mounted Jukebox on Location</b>	<b>5</b>
Location Power and Warnings	6
Jukebox Power and Reset Switch	7
Wall Mounting Instructions	8
IR Remote Installation Instructions	10
Testing the Unit	11
Lighting Controller	12
Marquee Display	12
<b>Section C - Sound System Set Up</b>	<b>13</b>
Extension Speaker Operation	14
Selecting Speaker Power	14
Selection Procedures	14
Extension Speakers Connected to Amplifier Channel + and – terminals	15
Amplifier Overload Check	15
<b>Section D - Service &amp; Maintenance</b>	<b>19</b>
Recommended Routine Maintenance	20
Calibrating the Touchscreen	21
Hard Drive Replacement	21
<b>Section E - Troubleshooting</b>	<b>23</b>
LED Indicators	24
Troubleshooting Charts	26
Connection Diagrams	28
<b>Section F - Parts Catalog</b>	<b>35</b>
Front Door	36
Currency Components	39
Currency Components	40
Electronic Components	41
Accessories	44

## **Important Safety Instructions**

---

1. Read these instructions.
2. Keep these instructions.
3. Heed all warnings.
4. Follow all instructions.
5. Do not use this apparatus near water.
6. Do not block any ventilation openings. Install in accordance with the manufacturer's instructions.
7. Do not install near any heat sources such as radiators, heat registers, stoves, or other apparatus (including amplifiers) that produce heat.
8. Do not defeat the safety purpose of the polarized or grounding-type plug. A polarized plug has two blades with one wider than the other. A grounding type plug has two blades and a third grounding prong. The wide blade or the third prong is provided for your safety. If the provided plug does not fit into your outlet, consult an electrician for replacement of the obsolete outlet.
9. Protect the power cord from being walked on or pinched, particularly at plugs, convenience receptacles, and the point where they exit from the apparatus.
10. Only use the attachments/accessories specified by the manufacturer.
11. Use only with the bracket specified by the manufacturer or sold with the apparatus.
12. Unplug this apparatus during lightning storms or when unused for long periods of time.
13. Refer all servicing to qualified service personnel. Servicing is required when the apparatus has been damaged in any way, such as when the power-supply cord or plug is damaged, liquid has been spilled or objects have fallen into the apparatus, the apparatus has been exposed to rain or moisture, does not operate normally, or has been dropped.



The exclamation point within an equilateral triangle is intended to alert the user to the presence of important operating and maintenance servicing instructions in the literature accompanying the jukebox.



The lightning flash with arrowhead symbol, within an equilateral triangle is intended to alert the user to the presence of uninsulated "dangerous voltage" within the product's enclosure that may be of sufficient magnitude to constitute a risk of electric shock to persons.

### **WARNING**



To reduce the risk of fire or electric shock, do not expose this apparatus to rain or moisture. No objects filled with liquid, such as vases, shall be placed on the apparatus.

### **AVERTISSEMENT**

Pour réduire le risque d'incendie ou un choc électrique, ne pas exposer cet appareil à la pluie ou à l'humidité. Aucun objet rempli de liquide, comme les vases, ne doit être placé sur l'appareil.

### **CAUTION!**

#### **RISK OF ELECTRIC SHOCK. DO NOT OPEN**

DO NOT REMOVE ANY COVERS, GUARDS, OR SHIELDS.  
NO USER SERVICEABLE PARTS ARE INSIDE THIS JUKEBOX.  
REFER SERVICING TO QUALIFIED SERVICE PERSONNEL.



### **ATTENTION!**

#### **RISQUE DE CHOC ÉLECTRIQUE. NE PAS OUVRIR**

NE JAMAIS RETIRER LES COUVERCLES, GARDES, OU DES BOUCLERS.  
AUCUNE PIÈCE RÉPARABLE DANS CE JUKEBOX.  
CONFIER L'ENTRETIEN DE PERSONNEL QUALIFIÉ.



## Section A - Jukebox Specifications

<b>NGX MINI 2</b>	
<b>Dimensions:</b> Uncrated: Height Width Depth Crated: Height Width Depth	31" 19.5" 8" 35" 24.5" 12"
<b>Weight:</b> Uncrated  Crated	66 lbs.  85 lbs.
<b>Amplifier:</b> Output Power: (Standard)  Protection:	1000 Wrms into 2 Ohm Load  Thermal and speaker overload Automatic, self resetting
<b>Voltage:</b> <b>Frequency:</b>  <b>LCD:</b>	115VAC 60Hz  18.5" HD flat screen
<b>Speakers:</b>	none

This page is intentionally left blank.



*Section B -  
Placing the Wall-Mounted Jukebox on Location*

- Location Power and Warnings
- Jukebox Power and Reset Switch
- Wall Mounting Instructions
- IR Remote Installation Instructions
- Testing the Unit
- Lighting Controller
- Marque Display

## Location Power and Warnings



The jukebox must have a clean source of properly-phased and grounded 115VAC power at 10 amps max. This **MUST** be provided 24 hours a day, 7 days a week. The outlet the jukebox is connected to must **NOT** be controlled by a switch, nor should the circuit breaker feeding it be shut off at night.



If the outlet is not properly phased, grounded, or is connected to an overloaded circuit, it must be corrected by a qualified electrician before using.

The main power distribution unit is the power supply. This device contains a 10 amp fuse with a separate ON/OFF power switch located on the bottom of the power supply chassis.

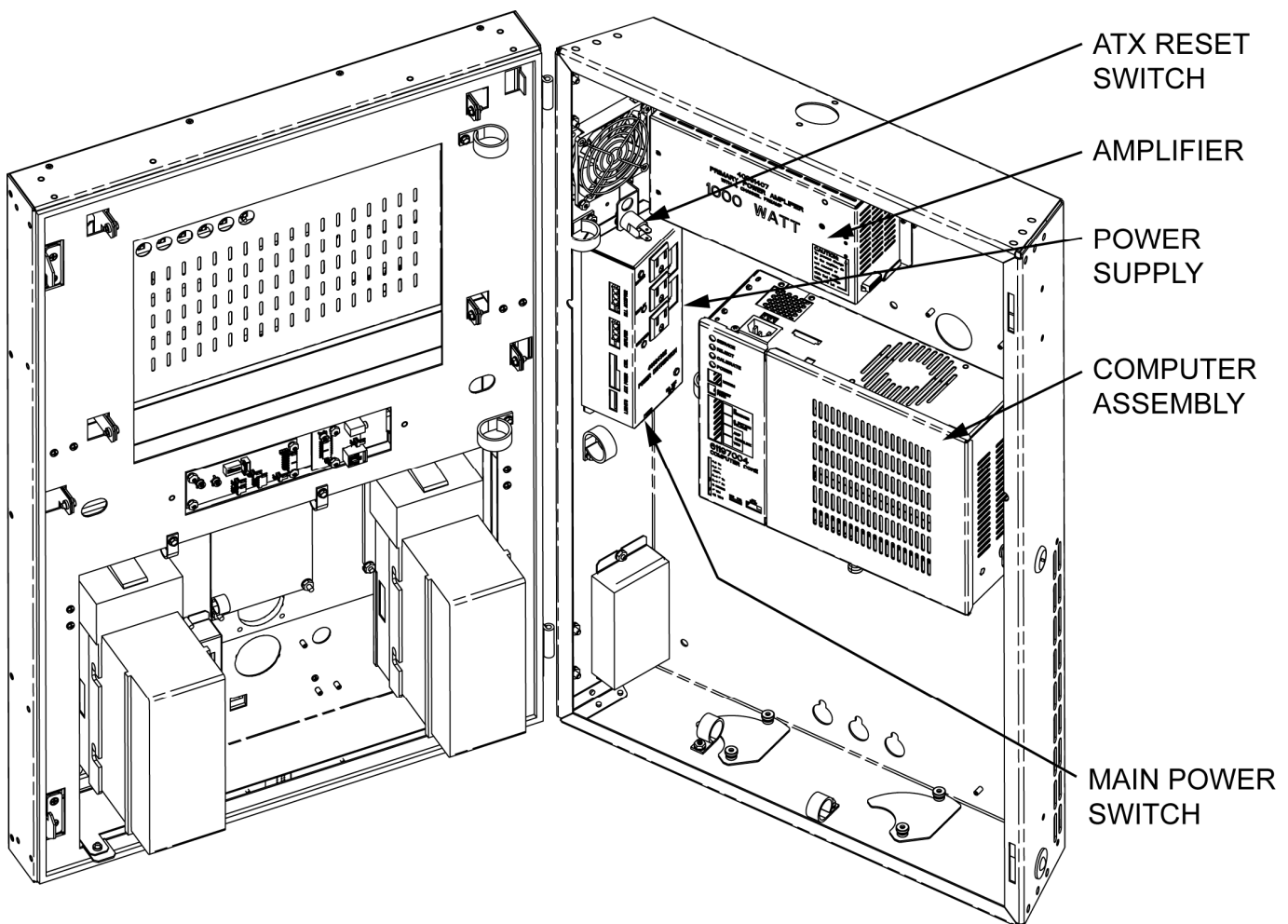

**Figure 1-B – Inside View of Cabinet  
with Front Door Opened**

## Jukebox Power and Reset Switch

---

The NGX MINI 2 jukebox is powered from a standard 115VAC wall plug using the provided power cord. Inside the jukebox, power is routed to a power distribution assembly located on the left-hand side of the cabinet (see *Figure 1-B*). This assembly includes a 10 amp fuse and separate power ON/OFF switch. All other components in the jukebox are powered by plugging them into this power distribution assembly.

### Soft Power Down

The Core Computer and other components in the jukebox should remain powered up at all times. However, there may be times when the jukebox needs to be turned off so that customers cannot insert money or make selections. The soft power down mode will give every outward appearance that the jukebox is off by turning off the lights, the LCD display, the bill acceptor(s), and the credit card reader; however, the Core Computer and other internal components remain powered up. There are multiple ways to enter and exit this soft power down mode:

- **Core Computer Power Button** – The button labeled “POWER” on the Core Computer inside the jukebox (see *Figure 1-B*) is used to enter the soft power down mode. Push it again to exit the soft power down mode.
- **IR Remote Control** – The button labeled “POWER” on the IR remote control transmitter will also toggle the soft power state just like the button described above.
- **6 Button Wired Volume Control** – This control can be modified to provide a POWER function. See *Wired 6 Button Volume Control* on page 10 for details.

### Computer Core

The jukebox Computer Core can be powered off by pressing the “SERVICE” button on the Computer Core (see *Figure 1-B*), and then touching “Shutdown Jukebox” on the touchscreen. This will turn off the Computer Core and other components that get their power from the ATX power supply in the Computer Core. To restore power after turning off the ATX power supply, the jukebox must be rebooted. Reboot the jukebox by toggling off the main power ON/OFF switch (see *Figure 1-B*) and then toggling it back on, or by pushing the ATX Reset Switch (see “ATX Reset Switch”).

### Hard Power Down

When the jukebox power cord is unplugged or the main power ON/OFF switch is turned off (see *Figure 1-B*), the jukebox is in the hard power down state. All power is removed from all components in the jukebox.

### ATX Reset Switch

There is a hidden ATX reset switch located inside the cabinet on the upper-left side just below the cooling fan (see *Figure 1-B*). It is accessible by either opening the jukebox door, or by inserting a paper clip, toothpick, or other long, thin object through the access hole on the left side of the jukebox.

- The **ATX Reset Switch** resets the Computer Core. This is like the reset switch on a PC. Pressing and releasing this switch will cause the computer main board to completely reboot. Use this switch only if the jukebox is completely non-responsive. Additionally, when the Computer Core has been powered down using the “Shutdown Jukebox” option in Service Mode, pushing this button will restart the computer.

## Wall Mounting Instructions

### Choosing the Location

The jukebox must be mounted on a strong, flat wall. It is recommended that a sub panel made from ¾" plywood or similar material be used and properly shimmed to provide a flat mounting surface. The jukebox should be visible and convenient to use. Do NOT install directly above a radiator or other source of heat. Be sure the speaker wires can be easily run to the unit.

#### WARNING



The mounting of the jukebox on the wall should be done by a qualified installer familiar with wall construction and loading. The wall and installation hardware **MUST** be capable of supporting a **700 lb.** load for the NGX MINI 2. Failure to follow these instructions could result in serious injury.

Tools and hardware required for normal installation into wood wall studs:

- Socket wrench with 3/8" and 7/16" sockets
- Level
- Pencil
- Punch or awl (to start the lag screws) and/or drill driver
- (4) 1/4" x 1-1/2" lag screws provided

### Mounting the Jukebox Cabinet

1. Remove the jukebox cabinet from its packing carton. Open the door, ensure all cables are detached from the door, and then lift the door off of the cabinet. Set the door aside for the moment.
2. Install a subpanel or locate a wall stud roughly in the center of where the jukebox will be mounted. See *Figure 2-B*.
3. Install the first ¼" x 1½" lag screw 65" up from the floor. If not using a subpanel, center the lag screw on a wall stud. This should be on the centerline of the jukebox. See *Figure 2-B*.
4. Hang the jukebox cabinet on this lag screw using one of the upper keyholes in the back of the jukebox cabinet (see *Figure 2-B*). Ensure the jukebox cabinet is level and mark the wall for the lower keyhole and the mounting holes in the top right and top left of the cabinet (See *Figure 2-B*).

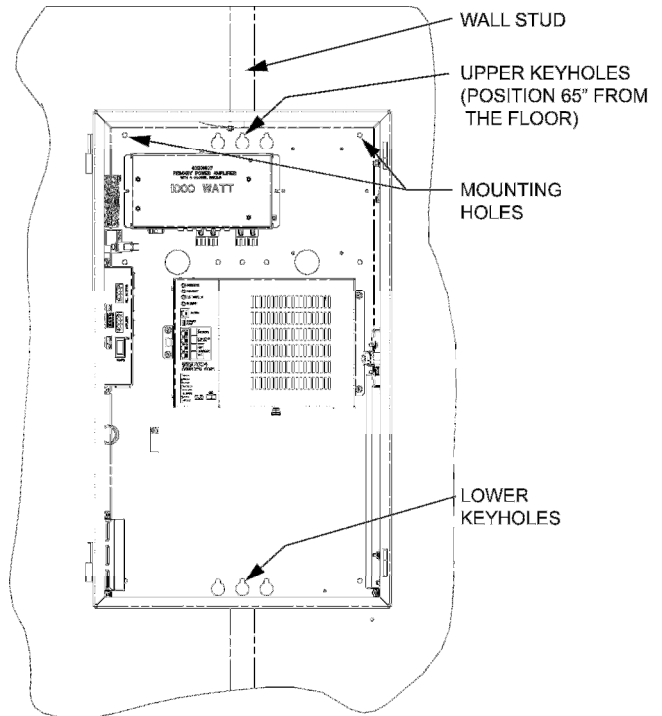

**Figure 2-B – Inside View of the Cabinet**

5. Remove the jukebox cabinet from the wall, drill pilot holes for the remaining lag screws, re-hang the jukebox cabinet and secure it to the wall using the additional lag screws provided.

**NOTE:** If the wall is concrete, cinder block, brick, or uses metal wall studs, then a subpanel with the appropriate fasteners must be used. At least 4" heavy-duty fasteners (one in each corner) must be employed. The fasteners and subpanel must be able to support a minimum 700 lbs. Do NOT use "press-in" anchors or any other "light" or "medium" duty fasteners. Consult a contractor experienced in the type of construction used if there is any doubt about the strength of the mounting devices.

6. Prepare the external wiring. The power cord, speaker wiring, and Ethernet cable can be routed to enter the top or the bottom of the jukebox. Use the block-out plates and nuts to secure the wiring.

- The front door is secured using slide hinges, which do not require tools to attach. To attach the front door, carefully lift the door, line up the hinge pins on the cabinet with the mating hinge barrels on the front door, and lower the door (see *Figure 3-B*).

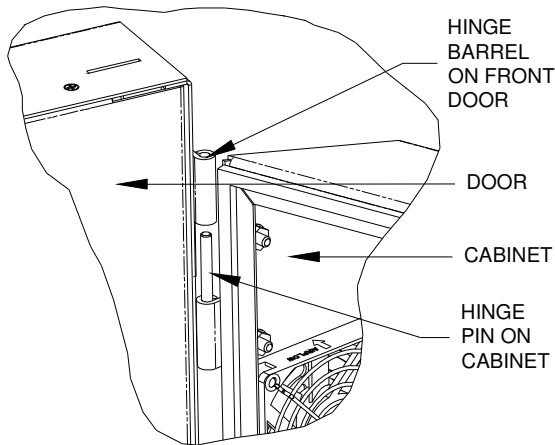

**Figure 3-B – Detail View of Top Cabinet Hinge**

- Locate the bundle of loose cables in the inside back of the cabinet. Route the cable bundle to the front door and into the cable clamps on the hinge side of the door (see *Figure 4-B*). Connect the LCD power, VGA, and USB Touch Controller cables to the back of the LCD.
- Connect the free end of the credit card reader cable (coming from the USB port on the Computer Core) to the card reader.
- Connect the free ends of the Audio cable, two-wire power connector, and Rowelink cable to the LED Controller Interconnect board.
- Connect the free ends of the 15-pin cables from the cabinet and door together.
- Make sure all cables are dressed properly. Use the cable clamps in the jukebox to keep cables in place. Make sure nothing interferes with opening and closing the door.

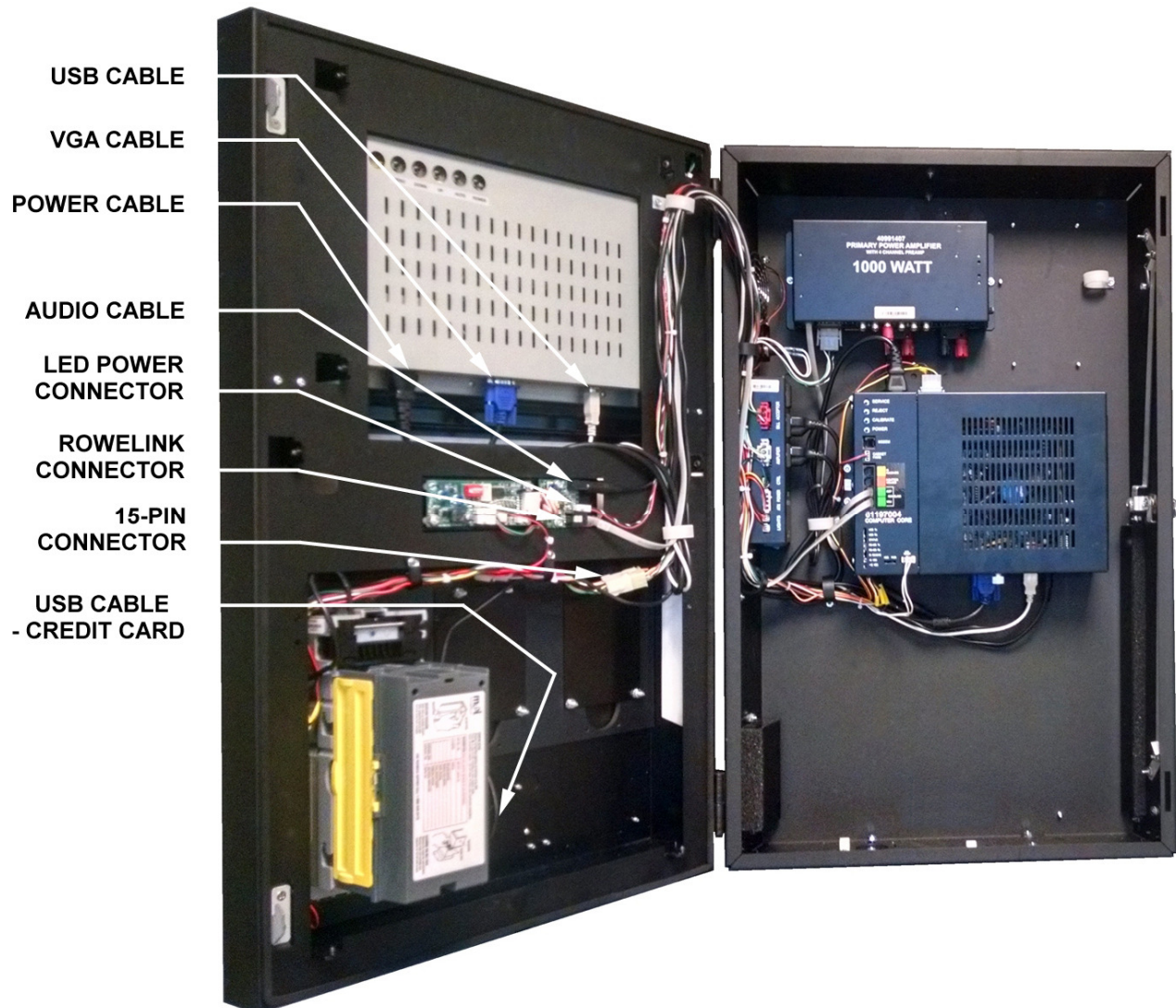

**Figure 4-B – Inside View of NGX MINI 2 Jukebox with Front Door Opened**

# IR Remote Installation Instructions

## IR Remote Control Installation Instructions

The NGX Mini 2 Jukebox comes with an IR remote (located in the Handy Pack). To install, plug the provided cable into the provided IR remote receiver (see *Figure 10-B*) and route the other end of the cable through one of the wire access holes in the cabinet. Connect the end of the cable into the port labeled “IR Receiver” on the Core Computer. Install the IR remote receiver above the jukebox, with a clear line of sight between the receiver and the handheld transmitter. Plug in and turn on the jukebox and test the remote.

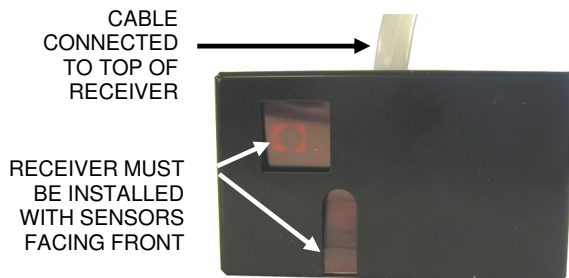

Figure 10-B – IR Remote Receiver

## Button Functionality on the IR Remote Transmitter

To enable or disable options on the IR remote, see “IR Remote Setup” in the *Network Setup, Jukebox Operation, Operator Setup Screens Manual*.

### REJECT

This button is used to cancel (or “reject”) the selection currently playing, and cancels all (rejects all) selections in the queue if held down for four seconds. This functionality can be enabled and disabled through the software.

### POWER

This button turns the lights, the LCD display, the bill acceptors, and the credit card reader ON/OFF. To turn them back on and resume normal operation, press the “POWER” button again.

### VOLUME

The **CH1+** and **CH2+** buttons raise the volume.

The **CH1-** and **CH2-** buttons lower the volume.

The **PLAY** button puts the jukebox in play mode.

The **PAUSE** button puts the jukebox in pause mode for a programmed amount of minutes or until the **PLAY** button is pushed.

The **AP OFF** and **AP ON** buttons turn any programmed Autoplay mode on/off.

The **FUTURE** button is used to give a remote credit.

The **VID SEL** button is used to enable and disable video selections on the jukebox.

## Wired 6 Button Volume Control

The NGX Mini 2 Jukebox also comes with a small 6 button wired remote control. This control is designed to be mounted close to the jukebox and provides some basic functions.

### INT.

These buttons change volume for Channels 1 & 2.

### EXT.

These buttons change volume for Channels 3 & 4.

### CANCEL

This button will cancel the selection currently playing.

### MUTE

This button toggles the jukebox between PAUSE mode and PLAY mode.



The MUTE button on this remote can be repurposed to function as a POWER button.

Remove the back cover of the remote control then remove the circuit board. There are two shunt jumpers located on the board. When these jumpers are both in the right hand position, the MUTE button functions as MUTE.

Move both shunt jumpers to the LEFT hand position to repurpose the MUTE button to function as a POWER button.

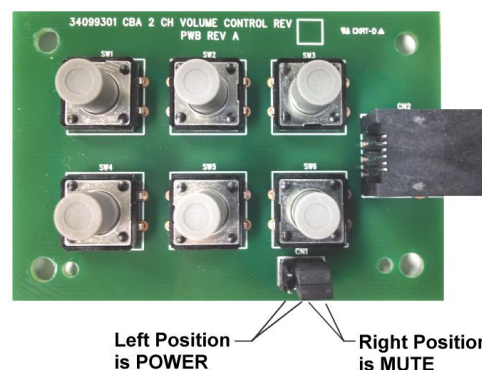

## Testing the Unit

---

### Initial Set Up

When all of the network connections have been made, boot up the jukebox. The first time you turn on the jukebox with a new hard drive, you will see the Local Music Configuration Screen, which lists the available local music configurations that can be installed on the jukebox. You will be prompted to select one of the available lists. This selection can be changed at any time by pressing the SERVICE button on the Computer Core, and then touching **System Setup -> Advanced Administration -> Local Music Configuration**.

Touch the **View** button to display a dialog box listing all of the albums in the selected list. Some albums may appear grayed out; this means that some or all of the songs in the album are not currently stored on this jukebox. If a list with grayed albums is installed, the grayed albums will start being downloaded to the jukebox within 24 hours (as long as the jukebox is connected). If the jukebox becomes disconnected, any songs not yet downloaded will be unavailable to patrons.

Touch the **Install** button to display a dialog box prompting you to install the selected list. To install the selected list, touch the Install button at the bottom of the dialog box.

### Testing the Touchscreen, Bill and Coin Acceptor(s), and Credit Card Reader

**Touchscreen** – Every time a new hard drive is installed, the touchscreen should be calibrated.

Follow these steps to calibrate.

1. Press the “CALIBRATE” button on the Computer Core (see *Figure 1-B*) to launch the calibration program.
2. Close the jukebox door and make sure it is locked.
3. Follow the directions on the screen, touching the center of the targets, and then touching different areas on the screen. If the cursor follows your movement, touch **YES** to exit.

### Bill/Coin Acceptor(s) and Credit Card Reader –

*(NOTE: Credit Card functionality requires a broadband Internet connection).*

1. Press the “SERVICE” button on the Computer Core to enter Service Mode.
2. Touch the **Diagnostics** button.
3. Touch **Credit Device Tests**.
4. To test the bill acceptor(s), insert a \$1, \$5, \$10, and \$20 bill (into each bill acceptor, if the jukebox has two) and check the screen to make sure proper credit is awarded.

5. To test the coin acceptor (if installed), deposit coins into the coin slot and verify proper credit is awarded.
6. To test the credit card reader, swipe a valid credit card and check that the screen displays the last four digits of the credit card.
7. When finished, touch the **Back** button to return to the Main Menu.

### Testing the Network

Enter Service Mode by pressing and releasing the “SERVICE” button on the Computer Core. To test the network:

1. Touch the **System Setup** button on screen and then touch **Advanced Administration**.
2. On the Advanced Administration Screen, touch **Configure Server**. Then touch the **Test Connection** button. This test confirms the jukebox can connect to AMI’s server (“Server Found”), and authenticate a connection with AMI’s server (“Connected”).
3. If the connection is successful, you will see “**Yes**” next to “**Server Found**” and “**Connected**”. If the connection fails, you will see “**No**”. If the connection fails, check the settings on the Network Information Screen (**Diagnostics** → **Network Information**). This screen will allow you to check the IP Configuration and run LAN and WAN tests.

### Testing the Audio

**NOTE:** For operators pre-testing the jukebox in their own facility, any features in the application associated with the network will not work unless the jukebox is connected to the Internet.

1. If the jukebox is not in Service Mode, press the “SERVICE” button on the Computer Core to enter Service Mode.
2. Add one (or more) credits to play a song and test the audio. Touch **Cash Management** and then touch **Credit Management**.
3. Touch the box under “Credits” and a pop-up box will display.
4. Touch **Clear** to remove the “0” from the box.
5. Touch **1** (or more) and then touch **Update**.
6. Touch **Save** on the Credit Management Screen.
7. Touch **Exit Service Mode**.
8. After connecting speakers to the jukebox (see section C), play a local music selection to test the audio.

## Lighting Controller

The NGX MINI 2 lighting assembly can be programmed for several different modes of operation. By default, the lighting assembly is set to display random colors and random patterns.

To change the mode, open the main door of the jukebox. The LED controller is located on the back of the door just above the currency panel. There are two adjustment pots on the board marked **BRIGHT** and **SPEED**. These are used to set the brightness of the LEDs and adjust the speed of color changes for the color cycle display modes.

The five position DIP switch is used to set the operating mode of the controller. Use the following table to set the mode.

### Beat to the Music

The NGX Mini 2 includes an audio interface, located next to the LED Controller, which allows the LEDs to change to the beat of the music.

To disable this feature, move jumper JP1 to the "P" position and rotate the pot R14 fully clockwise, or simply disconnect the audio cable going to the board.

SW1	SW2	SW3	SW4	SW5	Mode
OFF	OFF	OFF	OFF	ON	Color cycle – quick change between colors
ON	OFF	OFF	OFF	ON	Static – Red
OFF	ON	OFF	OFF	ON	Static – Yellow
ON	ON	OFF	OFF	ON	Static – Green
OFF	OFF	ON	OFF	ON	Static – Cyan
ON	OFF	ON	OFF	ON	Static – Blue
OFF	ON	ON	OFF	ON	Static – Magenta
ON	ON	ON	OFF	ON	Static – White
OFF	OFF	OFF	ON	ON	Static – Orange
ON	OFF	OFF	ON	ON	Static – Rose
OFF	ON	OFF	ON	ON	Color cycle – Rainbow: Pastels
ON	ON	OFF	ON	ON	Color cycle – Patriotic: Red, White and Blue
OFF	OFF	ON	ON	ON	Color cycle – Holiday: Reds and Greens
ON	OFF	ON	ON	ON	Color cycle – programmed colors and patterns
<b>OFF</b>	<b>ON</b>	<b>ON</b>	<b>ON</b>	<b>ON</b>	<b>Color cycle – random colors and patterns (default)</b>
ON	ON	ON	ON	ON	Color cycle – gradual change between colors
---	---	---	---	OFF	LED lighting OFF

## Marquee Display

### Graphic Panel

The back lit Graphic Panel in the marquee can easily be changed to your own custom panel. To change the graphic panel, follow these steps.

1. Power off the jukebox.
2. Disconnect the 15 pin connector separating the door harness from the cabinet harness. Disconnect the two pin connector at J2 of the LED Controller, disconnect the USB cable at the back of the card reader.
3. Remove the two cable clamps holding the door harness (or take the harness out of the clamps).
4. Remove the 4 screws holding the currency panel to the door. Remove the currency panel from the front of the jukebox.
5. Place the currency panel face down on a work surface. Remove two #8-32 hex nuts and lift off the backlight panel. Remove the clear spacer and the graphic panel.

Place the new graphic panel in the opening and reverse the steps to reinstall your currency panel.

### Graphic Panel specifications (recommended):

Material: Backlit Duratrans (or equivalent)

Finished thickness: 7 mils

Dimensions: 3-1/4" high x 14" long

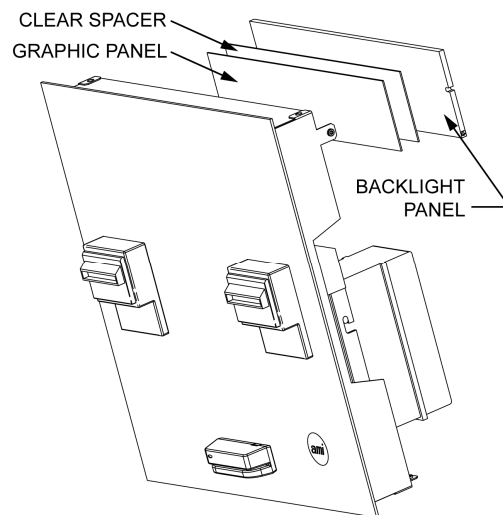



*Section C -  
Sound System Set Up*

- Extension Speaker Operation
- Selecting Speaker Power
- Speaker Connection Diagrams

## Sound System Set Up

---

The NGX Mini 2 jukebox sound system is powered by a 1000 Watt S-Pro2 Class 2 power amplifier manufactured by Pascal. Speaker terminals are provided to connect extension speakers directly to the amplifier. An Audio Output Transformer Kit (part number 22180806) is available if your installation uses 70 volt speakers or you need to connect extension speakers using various power taps.

### Extension Speaker Operation

To avoid poor sound quality, care must be taken when adding extension speakers. The following requirements must be met:

- Speakers connected to the amplifier must be wired so the power consumed by the extension speakers does not exceed the amplifier power rating of 500 watts per channel.
- Complete the Extension Speaker Worksheet (*Table 1-1*) for each channel and verify it does not exceed the 500 watt amplifier channel rating. After wiring the speakers, perform the Amplifier Overload Check immediately following *Table 1-1*.
- All speakers must be connected with the correct polarity (see *Figure 1-A*).
- Do not bridge output channels.

### Low Impedance Speakers

Low impedance speakers (16, 8, or 4-ohm) can be used when the connecting cable is less than 100 feet. Keep the following two things in mind when wiring your speakers:

1. No more than one 4-ohm speaker should be connected to a speaker line. If several 4-ohm speakers are to be used, each speaker should have its own line.
2. The loss in 100 feet of 18-gauge zip-cord feeding on an 8-ohm speaker is 15%. The loss for two 8-ohm speakers is 30%.

### Selecting Speaker Power

#### General Instructions

This section will lead you through the power and speaker selection process. This process consists of three major steps and several smaller steps. The major steps are:

1. Identify the extension speakers and compute the speaker power for speakers connected directly across the amplifier.
2. Make the extension speaker connections.
3. Perform an amplifier overload check (see instructions immediately following *Table 1-1*).

#### Selection Procedures

- Use a pencil (you may want to revise your figures) to fill in the Extension Speaker Worksheet on the following pages.
- Use the *Table 1-1* Worksheet to help you calculate the amount of power consumed by the extension speakers.
- An extension speaker RMS power rating should be at least 10% higher than the power it will consume at maximum jukebox volume.

When RMS power to speaker  
at maximum jukebox volume is:

240 watts  
120 watts  
60 watts  
30 watts

Then recommended RMS power  
rating of speaker is:

300 watts  
150 watts  
75 watts  
40 watts

---

**Table 1-1 – Extension Speaker Worksheet**  
**Sheet 1**

**Extension Speakers Connected to Amplifier Channel + and – terminals**

Place the quantity of speakers in the blank under **Qty** and multiply the quantity times the power consumption. Place your results in the blank under **Total**.

	<b>Qty</b>			<b>Total</b>	
	<b>CH 1</b>	<b>CH 2</b>		<b>CH 1</b>	<b>CH 2</b>
Two 8-ohm speakers in series: (30 watts to each speaker)	_____	_____	at 60 watts per series =	_____	_____ watts
Two 4-ohm speakers in series: (60 watts to each speaker)	_____	_____	at 120 watts per series =	_____	_____ watts
8-ohm speakers:	_____	_____	at 120 watts each =	_____	_____ watts
4-ohm speakers:	_____	_____	at 240 watts each =	_____	_____ watts
Total Load, sum Total columns for CH1 and CH2				_____	_____ watts

---

**Amplifier Overload Check**

Check that the amplifier is not overloaded by performing the following steps:

1. Make sure that the extension speakers are connected to the amplifier terminals properly (Channel1 + – and Channel 2 + –).
2. If the red OVERLOAD LED is always lit, the amplifier is overloaded and will shut down. You must perform Step 3.
3. Do this step only if the OVERLOAD LED came on as described in Step 2.
  - Find the source of the overload (shorted speaker wires, shorted speaker, too many speakers connected).
  - After you fix the short, disconnect a few speakers to reduce the wattage. Repeat Step 2.
  - If no overload is detected, reconnect the disconnected speakers (ensure you do not have too many speakers, use Table 1-1). Repeat step 2.

**NOTE: SPEAKER WATTAGE SHOWN IS RATING OF SPEAKER**

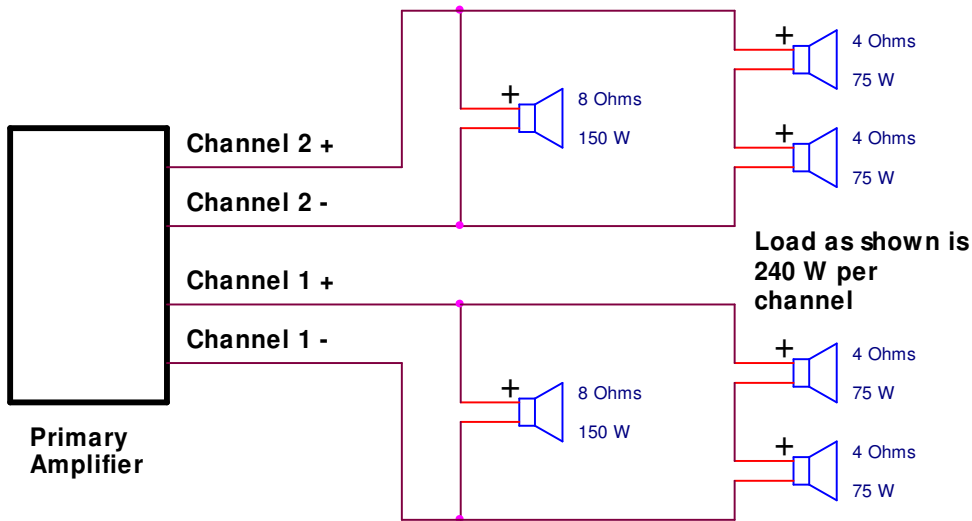
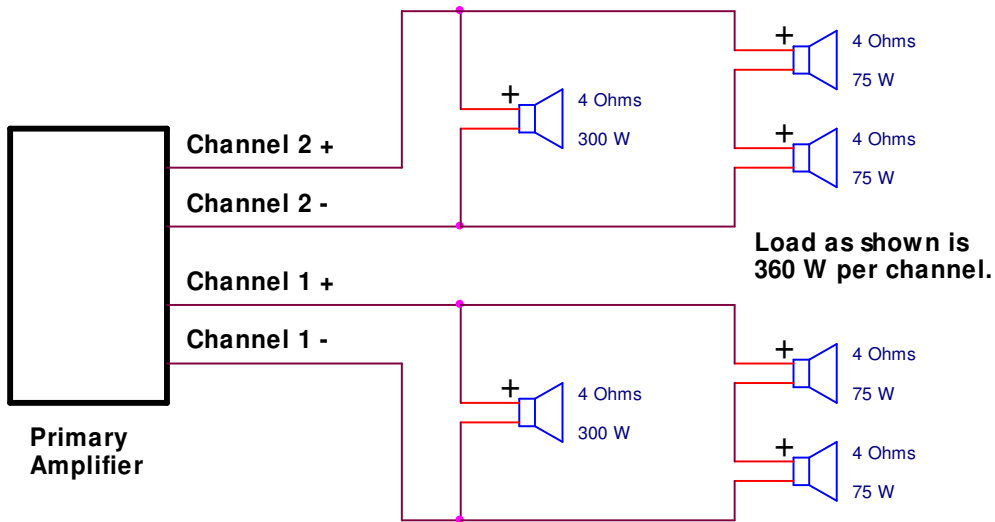
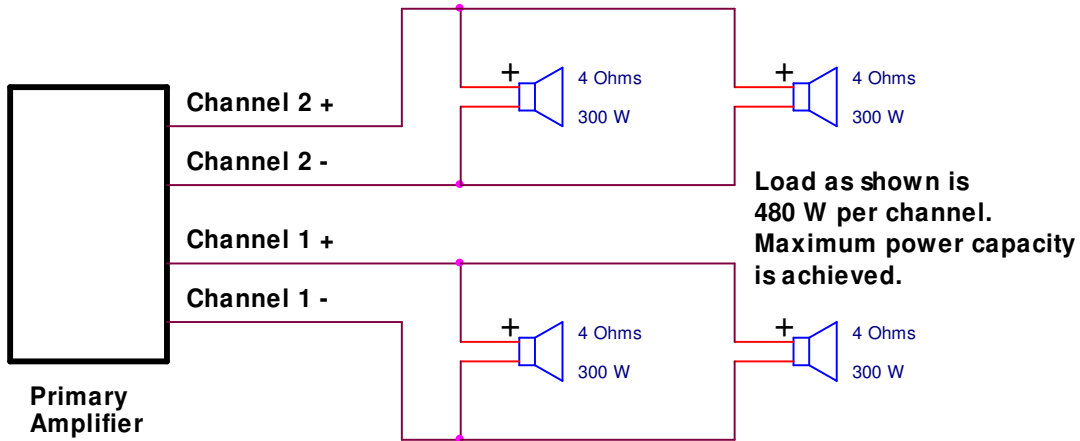

**Figure 1-C**

**NOTE: SPEAKER WATTAGE SHOWN IS RATING OF SPEAKER**

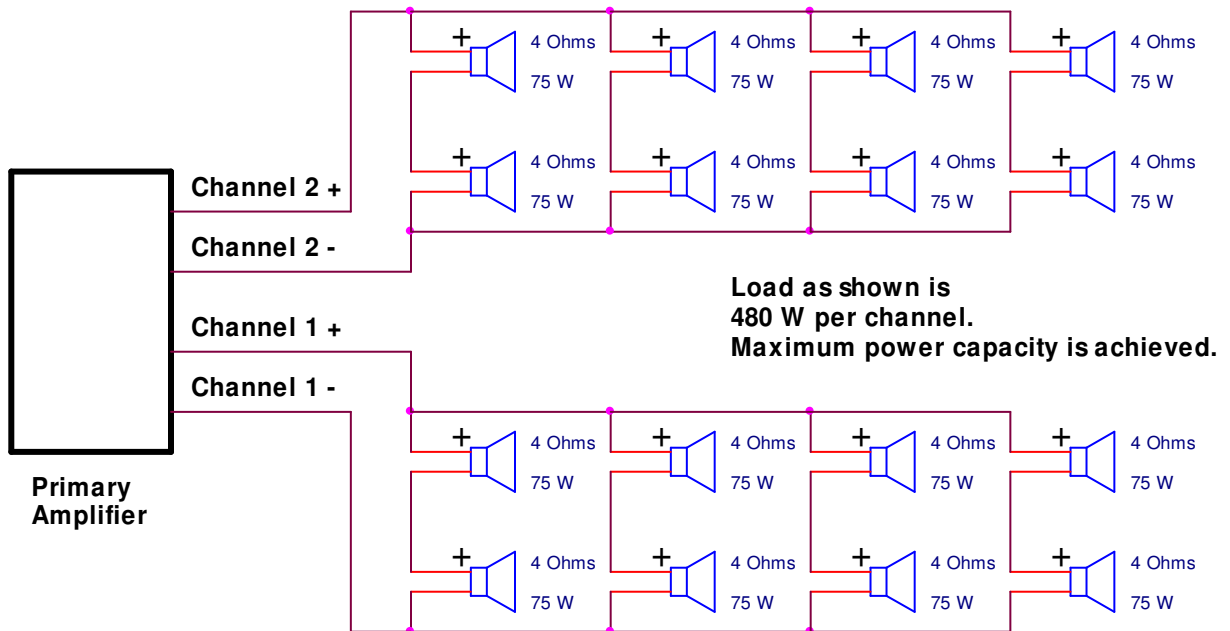
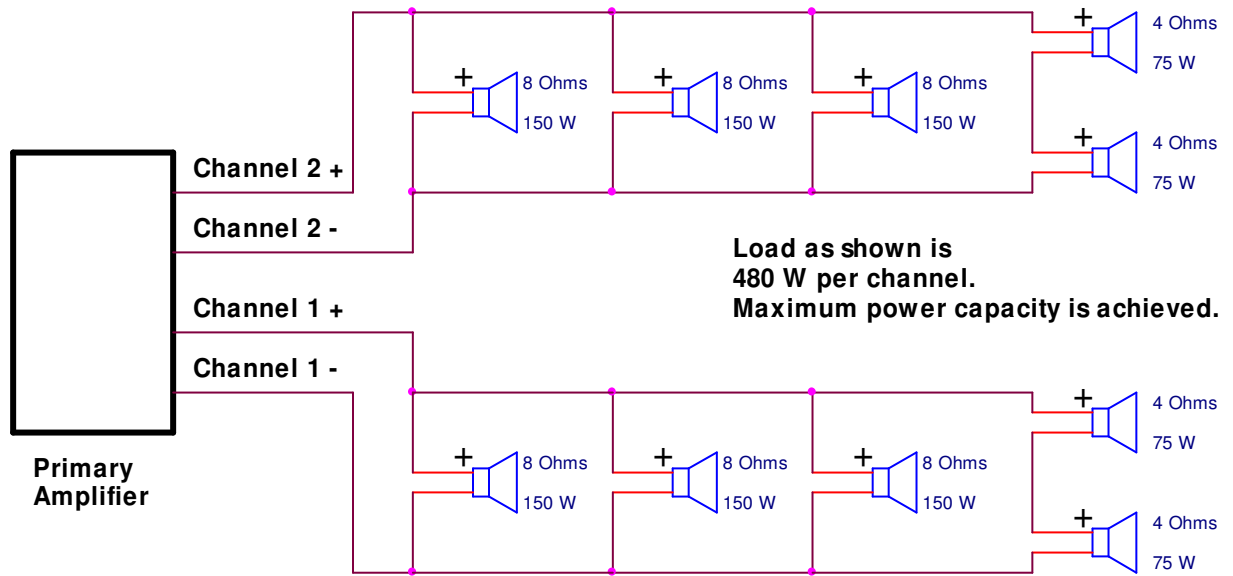

**Figure 1-C (continued)**

This page is intentionally left blank.



*Section D -  
Service & Maintenance*

- Recommended Routine Maintenance

## Recommended Routine Maintenance

**Heat is the biggest enemy of electronic components. Proper maintenance is essential for maximum earnings and reliability.**

It is very important to keep all cooling fans clean. Once dust and dirt is visible on a cooling fan, the airflow can be reduced by 25% or more. There are several cooling fans in the cabinet (see *Figure 1-D*).

### Recommended preventative maintenance

#### Routine Service

The following steps take about 3 minutes and should be performed at each collection.

1. Check the CPU fan from the “Health Status” Screen.
2. Ensure the cabinet fan at the upper-left side of the cabinet is blowing air out and the fan looks clean. See *Figure 1-D*.
3. Be sure that nothing is resting on top of the unit or otherwise blocking the airflow around the machine.

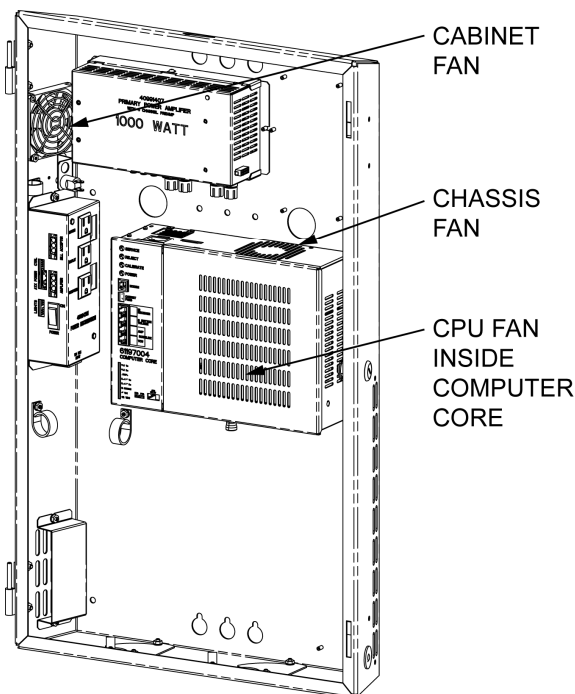

**Figure 1-D – Inside View of Cabinet**

#### Collecting from the Bill Acceptor

1. Unlock and open the front door.
2. To remove the bill stacker, slide the tab on the bottom of the bill acceptor towards the front door, push the stacker downward then pull it off the bill acceptor.
3. Open the side door on the bill stacker to remove the cash.
4. Push the Service button to access the Collect Now function to help manage and audit your collections.

5. Slide the bill stacker back on the bill acceptor. Be sure the green light is on (for MEI, make sure the green lights/arrows are flashing).
6. Close and lock the jukebox door.

#### Minor Service

Perform these steps a minimum of every 3 months if operating more than 14 hours per day, operating where smoking is allowed, or operating in a dusty environment. Perform these steps a minimum of every 6 months if operated less than 14 hours per day and in a very clean environment. You will need a new, soft 2” paintbrush\*.

1. Gently brush\* dirt from the cabinet cooling fan. Verify fan operation.
2. Check the operation of the CPU fan from the “Health Status” Screen.
3. Listen to the CPU fan for excessive noise or vibration. Replace faulty fans as needed.
4. Clean the bill acceptor with an approved cleaning card.
5. Clean the credit card reader with an approved cleaning card.
6. Clean then calibrate the touchscreen (see the next page for calibration instructions).

#### Cleaning the Touchscreen

Any standard glass cleaner can be used to clean the touchscreen. Always spray the glass cleaner on the cloth or towel and not directly on the touchscreen. Glass cleaner sprayed directly on the screen could possibly leak inside and cause damage.

#### Cleaning the Currency Panel

The door panel is made of plastic. We recommend cleaning with a mild cleaner and a soft cloth to avoid scratching the surface.

#### Annual Service

The following steps should be performed every year in addition to everything in the minor service section.

1. Vacuum the interior of the cabinet and fans.
2. Inspect the power cord for fraying or damage.
3. Check the power ground.
4. Check all LAN connections and wiring.
5. Listen to all speakers to make sure they are operating correctly.

**Scheduled maintenance always costs less time and money than an unscheduled breakdown.**

## Calibrating the Touchscreen

Every time a new hard drive is installed, the touchscreen should be calibrated. Follow these steps to calibrate.

1. Press the “CALIBRATE” button on the Computer Core (see *Figure 2-D*) to launch the calibration program (see *Figure 3-D*).

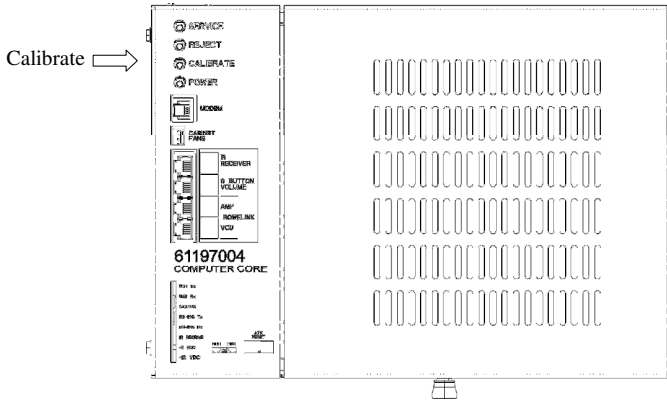

**Figure 2-D – Computer Core**

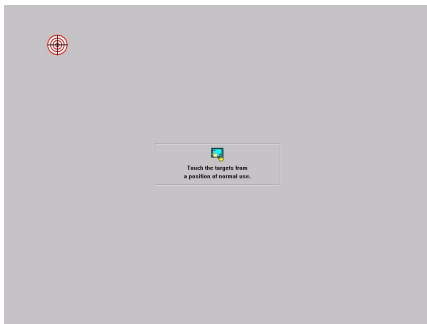
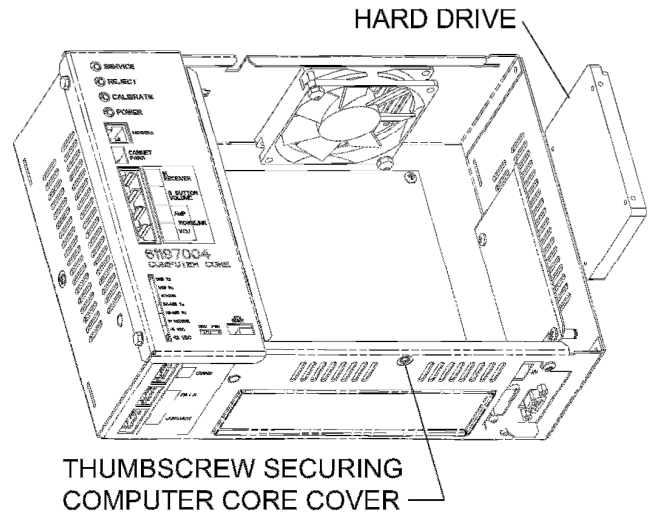

**Figure 3-D – Calibration Screen**

2. Close the jukebox door and make sure it is locked.
3. Follow the directions on the screen, touching the center of the targets, and then touching different areas on the screen. If the cursor follows your movement, touch **YES** to exit.

## Hard Drive Replacement

1. Turn off and unplug the jukebox.
2. Loosen the thumbscrew securing the cover on the Computer Core and slide it off (see *Figure 4-D*).



**Figure 4-D – Computer Core**

3. Carefully slide the hard drive out of the assembly as far as cabling will allow.
4. Disconnect the SATA power and data cables from the drive.
5. Connect the SATA power and data cables to the new hard drive.
6. Slide the hard drive back into the assembly. Make sure not to pinch any cables while doing so. Also make sure cables are not interfering with cooling fans.
7. Replace the Computer Core cover and secure it with the existing thumbscrew.

This page is intentionally left blank.



*Section E -  
Troubleshooting*

- LED Indicators
- Troubleshooting Chart
- Connection Diagrams

## ***LED Indicators***

---

The LEDs are described below to help you isolate a problem.

### **COMPUTER CORE ASSEMBLY (61197004)**

**USB Tx LED** – It should be flashing, indicating good communication between the motherboard and the I/O board.

**USB Rx LED** – It should be flashing, indicating good communication between the motherboard and the I/O board.

**STATUS LED** – Flashes three times on power up, but otherwise it should be off.

**RS485 Tx LED** – It should be flashing, indicating good communication between the I/O board and Rowelink devices such as the Amplifier and Volume Control Units.

**RS485 Rx LED** – It should be flashing, indicating good communication between the I/O board and Rowelink devices such as the Amplifier and Volume Control Units.

**IR RECEIVER LED** – Flashes when an IR signal is received.

**+5VDC** – Indicates this voltage from the ATX power supply is present.

**+12VDC** – Indicates this voltage from the ATX power supply is present.

**HDD LED (RED)** – Flashes when the motherboard is accessing data on the hard drive.

**PWR LED (GREEN)** – When lit, indicates the power supply in the Computer Core assembly is on.

### **PRIMARY POWER AMPLIFIER ASSEMBLY (40991407)**

**POWER (Green)** – When lit, indicates power is applied to the Amplifier.

**STATUS (Red)** – Indicates the status of the Preamplifier/Amplifier.

**COM (Green)** – Quick flashes indicate communication with the Core Computer is OK.

**MUTE (Red)** – Indicates the mute status of the Amplifier (On = muted, Off = not muted)

**OVERCURRENT** – When lit, indicates the Amplifier is overloaded. Verify speaker load and ensure there are no shorted speaker wires.

**THERMAL** – When lit, indicates the Amplifier is overheating. Be sure the cabinet fan(s) are working, the filters are clean, and nothing is blocking air flow through the cabinet.

**RAIL VOLTAGE** – When lit, indicates the Amplifier power supply is on or the power supply capacitors have not yet discharged. To prevent damage to the Amplifiers, DO NOT connect or disconnect the cable between the Primary Amplifier and the Secondary Amplifier while these two LEDs are lit.

**Preamplifier STATUS – normal operation**

The STATUS LED is used to indicate the status of the preamplifier. Under normal conditions the STATUS LED will flash once on power up, stay off for a second, and then turn back on and stay on. If either of the two microphone inputs become active, either by activation of the SENSE line or by the Voice Activation Circuits, the STATUS LED will blink on and off at a 150ms rate until the microphone circuits become inactive.

**Preamplifier STATUS – error conditions**

The STATUS LED is used to indicate possible faults on the preamplifier board. During power up, the preamplifier runs a self test. If a fault is detected, the STATUS LED is used to indicate what may be wrong. The LED will repeat a pattern of a specific number of blinks.

The blink pattern is 500ms on, 500ms off and then one to seven quick 100ms on blinks, three seconds off. The blinking pattern will repeat until the preamplifier is reset or power is turned off.

Number of Blinks	Problem Description
1	Digital Audio Processor did not come out of RESET
2	Digital Audio Processor COM error
3	EEPROM COM error
4	Digital Audio Processor memory load error
5	EEPROM data error
6	Digital Potentiometer COM error in Mic circuit
7	I <sup>2</sup> C SDA line is stuck low

If the DAP (Digital Audio Processor) fails during normal operation, after power up the STATUS led will start to blink one second on, two seconds off, continuously until power is cycled or until the DAP failure goes away.

**Preamplifier Jumpers**

There are 5 jumpers on the preamplifier. They are preset at the factory and should not have to be reconfigured.

The preamplifier will support both the IcePower 250ASX2 500 watt power amplifier and the Pascal S-PRO2 1000 watt power amplifier. JP2 and JP3 must be set to match the power amplifier in use.

**JP1: LOAD** – used to set the speaker load. This jumper affects the S-PRO2 1000 watt amplifier only.

**JP2, JP3: AMPLIFIER TYPE** – used to configure the preamplifier power supply. Set both jumpers to match which amplifier is being used. If these jumpers are set in the wrong position, the preamplifier will not work.

**JP4, JP5: MODE** – set these jumpers to the STANDARD position for normal operation. The SUB position implements a High Pass Filter on Channel 1 and a Low Pass Filter on Channel 2.

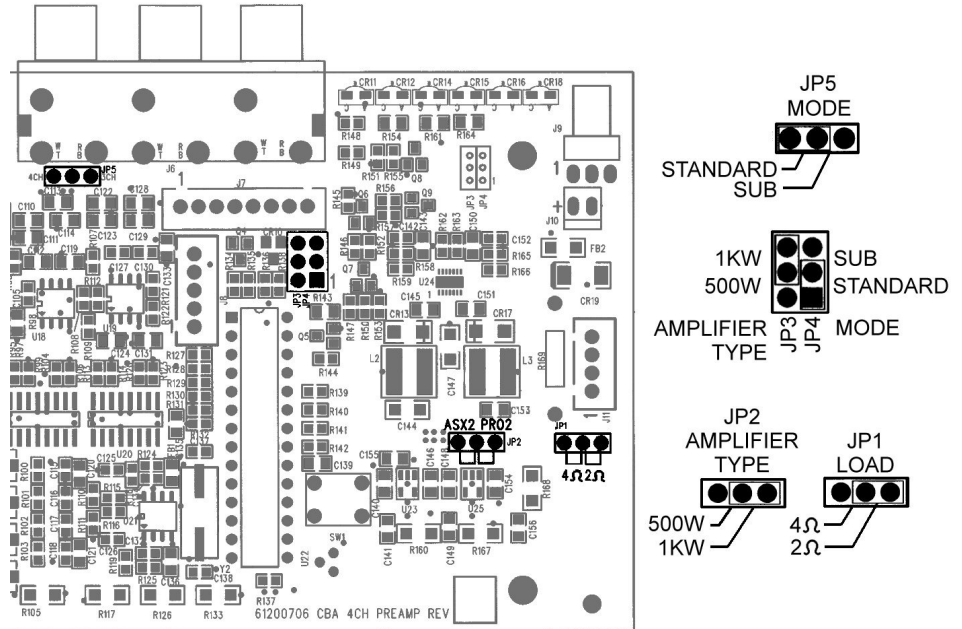

**Figure 1-E – Preamplifier Jumpers**

## Troubleshooting Charts

The best way to isolate a problem is to determine its cause. The following charts should help to narrow down which module is failing and whether it can be fixed or it needs to be replaced.

Start with finding the “Problem” column that relates the closest to the problem you are experiencing and then match it to the closest “Symptom”. There can be many “Probable Causes” listed for each Symptom. The Probable Causes are listed in decreasing order of probability.

PROBLEM	SYMPTOM	PROBABLE CAUSE
<b>The Windows operating system does not boot up.</b>	At the first boot up screen, “PASSWORD”	<ol style="list-style-type: none"> <li>1. There is no hard drive in the Computer Core.</li> <li>2. The plugs are not completely seated in the hard drive.</li> <li>3. The data cable or power cable has come loose from the motherboard or hard drive.</li> </ol>
	The boot up process stops at “DISK BOOT FAILURE, INSERT SYSTEM DISK AND PRESS ENTER.”	<ol style="list-style-type: none"> <li>1. There is no hard drive in the Computer Core.</li> <li>2. The data cable or power cable has come loose from the motherboard or hard drive.</li> <li>3. The hard drive is faulty.</li> </ol>
<b>The LCD screen stays dark when the jukebox is powered up.</b>	The PWR LED on the Computer Core does not light.	<ol style="list-style-type: none"> <li>1. The plug is not completely inserted into the outlet.</li> <li>2. The wall circuit is not “hot”.</li> <li>3. The ON/OFF switch on the power supply is in the OFF position.</li> <li>4. The ATX power supply in the Computer Core is faulty.</li> </ol>
	The LEDs on the Computer Core come on, but the screen stays dark.	<ol style="list-style-type: none"> <li>1. The power plug to the display is not seated completely.</li> <li>2. The power distribution assembly is defective.</li> <li>3. The LCD is faulty.</li> </ol>
<b>The LCD briefly shows “NO CABLE” or “NO VIDEO SIGNAL”.</b>	The computer fan is on and all system’s LEDs and lights are normal.	<ol style="list-style-type: none"> <li>1. The video cable wiring is not seated completely.</li> <li>2. The LCD is defective.</li> <li>3. The Computer Core is defective.</li> </ol>
<b>The touchscreen does not work.</b>	The application boots up, but the touchscreen does not respond to touch.	<ol style="list-style-type: none"> <li>1. The USB cable is not seated completely at the LCD or at the Computer Core.</li> <li>2. The touchscreen is not calibrated.</li> <li>3. The touchscreen is defective.</li> </ol>
<b>The touchscreen will not calibrate.</b>	Nothing happens after pressing the calibration button.	<ol style="list-style-type: none"> <li>1. The I/O interface board in the Computer Core is faulty.</li> <li>2. The hard drive is faulty.</li> <li>3. The Computer Core is faulty.</li> </ol>
	The calibration program runs, but will not respond to touch.	<ol style="list-style-type: none"> <li>1. The USB cable plug is not fully seated at the LCD or at the Computer Core.</li> <li>2. The touchscreen controller is faulty.</li> <li>3. The touchscreen sensor (glass) is faulty.</li> <li>4. The motherboard in the Computer Core has failed.</li> </ol>
<b>No music from jukebox.</b>	No sound from jukebox, although the application reports “Now Playing...a New Song.”	<ol style="list-style-type: none"> <li>1. Volume control is turned all the way down.</li> <li>2. The audio mode input routing or muting is configured incorrectly.</li> <li>3. Audio cables are disconnected or loose from the Computer Core or the preamplifier.</li> <li>4. Volume control is broken.</li> <li>5. The amplifier is overloaded and shutdown.</li> </ol>
	No sound from jukebox and the application doesn’t appear to be playing the song selected.	<ol style="list-style-type: none"> <li>1. There are no more credits available for play.</li> <li>2. Reject song was activated.</li> </ol>

PROBLEM	SYMPTOM	PROBABLE CAUSE
<b>Machine is locked up during normal runtime.</b>	Bill acceptor is taking money but credits are not accumulating, the touchscreen is not responsive, and I/O board LEDs are not flashing.	The Computer Core is locked up. Reboot it by pressing and releasing the ATX Reset Switch. If the Computer Core does not boot up, perform a complete Power Down and Power Up.
<b>The bill acceptor does not work.</b>	Lights on the bill acceptor are lit, but the bill acceptor will not accept a bill.	<ol style="list-style-type: none"> <li>1. The bill acceptor bill box is full.</li> <li>2. The bill box was not re-installed on the bill acceptor correctly.</li> <li>3. There is a jammed bill in the device.</li> <li>4. The plugs are not inserted securely at the acceptor.</li> <li>5. The bill acceptor is defective.</li> </ol>
	The lights on the bill acceptor are not flashing.	<ol style="list-style-type: none"> <li>1. The cable is damaged at the acceptor.</li> <li>2. The jukebox has disabled the bill acceptor. Put the jukebox into normal operating mode.</li> <li>3. The bill acceptor is defective.</li> </ol>
<b>Location network line not installed in the location.</b>	There is no designated broadband line installed in the location.	<ol style="list-style-type: none"> <li>1. The inside wiring installation appointment was not scheduled.</li> <li>2. The inside wiring installation has not occurred.</li> <li>3. The line was not installed in the pre-selected location.</li> <li>4. The line (jack) was not labeled by the technician.</li> </ol>
<b>Router does not work.</b>	When the power supply is connected to the router, nothing happens.	<ol style="list-style-type: none"> <li>1. The AC power plug is not fully inserted in the receptacle on the back of the router.</li> <li>2. Router reset circuit in power distribution assembly is defective.</li> </ol>
	The "Link/Act #" light (on the front of the router) does not light up when an Ethernet cable is plugged in the respective port.	<ol style="list-style-type: none"> <li>1. The cable is loose at the Computer Core or router.</li> <li>2. The jukebox is not powered on.</li> <li>3. The Ethernet port is defective.</li> </ol>
	The WAN light does not light up.	<ol style="list-style-type: none"> <li>1. The broadband connection is not plugged into the WAN port.</li> <li>2. The cable modem or DSL modem is not powered on.</li> </ol>
<b>The "Music On Demand" feature does not work.</b>	The feature has never worked in the location before.	<ol style="list-style-type: none"> <li>1. There is no Ethernet cable connection between the router and the jukebox.</li> <li>2. The Ethernet cable is not fully seated in the port on the Computer Core or in the back of the router.</li> <li>3. The connection is loose between the installed line and the router.</li> <li>4. The cable is bad.</li> <li>5. The Internet line is down.</li> <li>6. The hard drive trigger code was not entered.</li> </ol>
	The feature did work at one time, but is no longer available.	<ol style="list-style-type: none"> <li>1. The connection has become loose between the router and the jukebox.</li> <li>2. The connection has become loose between the installed line (jack) and the router.</li> <li>3. All the lights on the front of the router are ON.</li> <li>4. The router was shut off or lost power.</li> <li>5. The Internet service provider (ISP) is down.</li> <li>6. The AMI Entertainment server is down.</li> </ol>

# Connection Diagrams

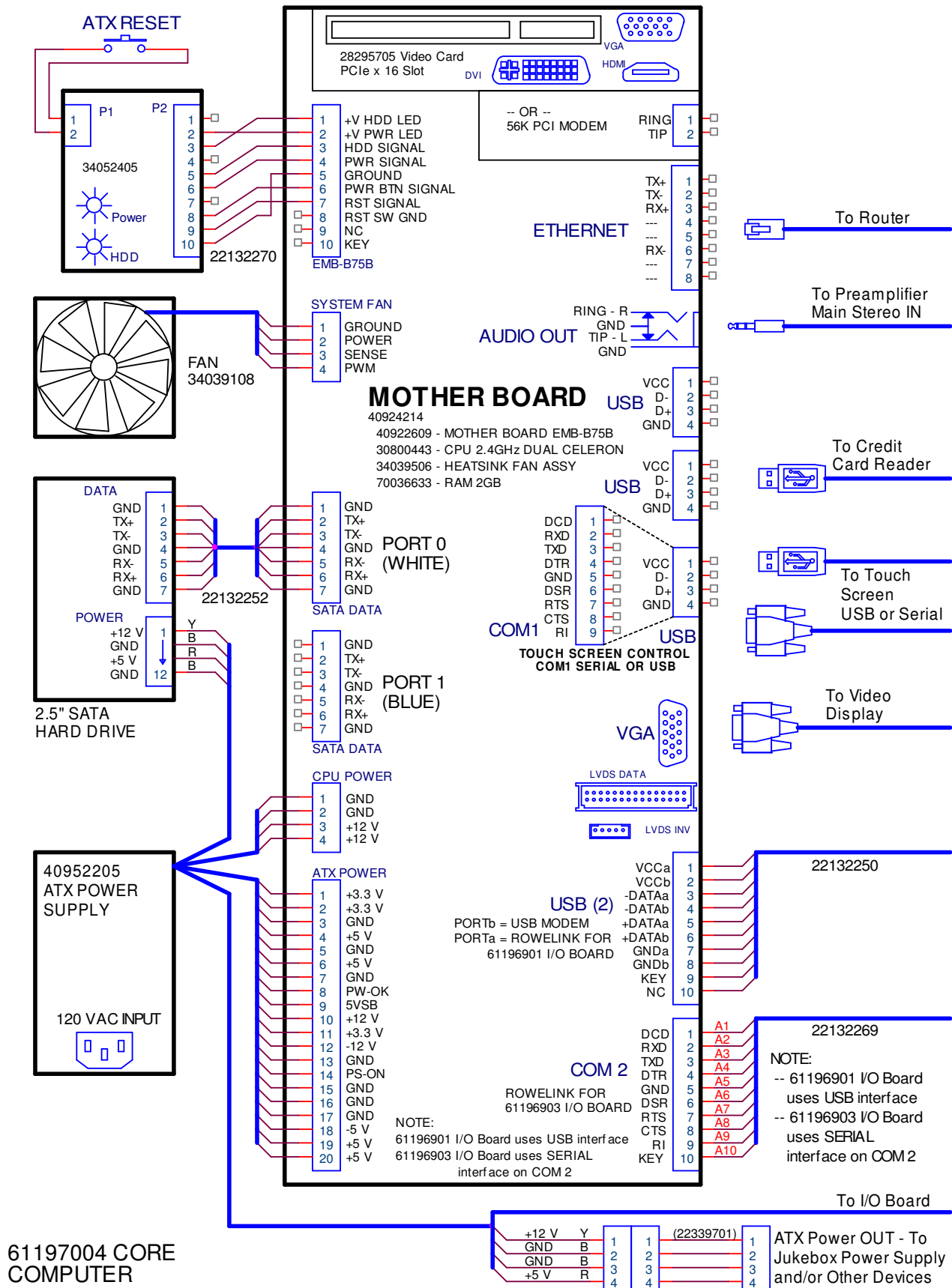

NGX MINI 2 COMPUTER CORE SCHEMATIC (PAGE 1)

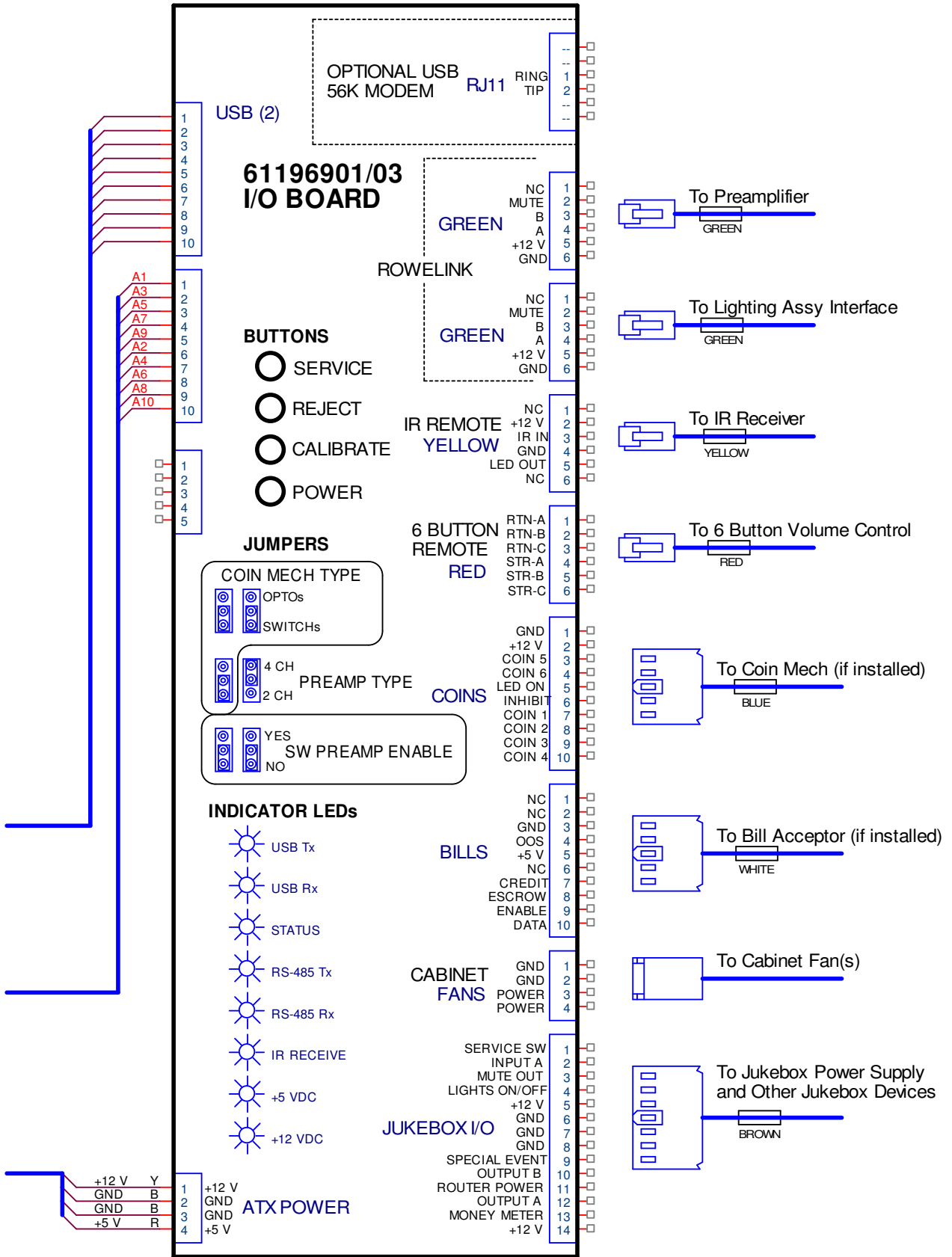

NGX MINI 2 COMPUTER CORE SCHEMATIC (PAGE 2)

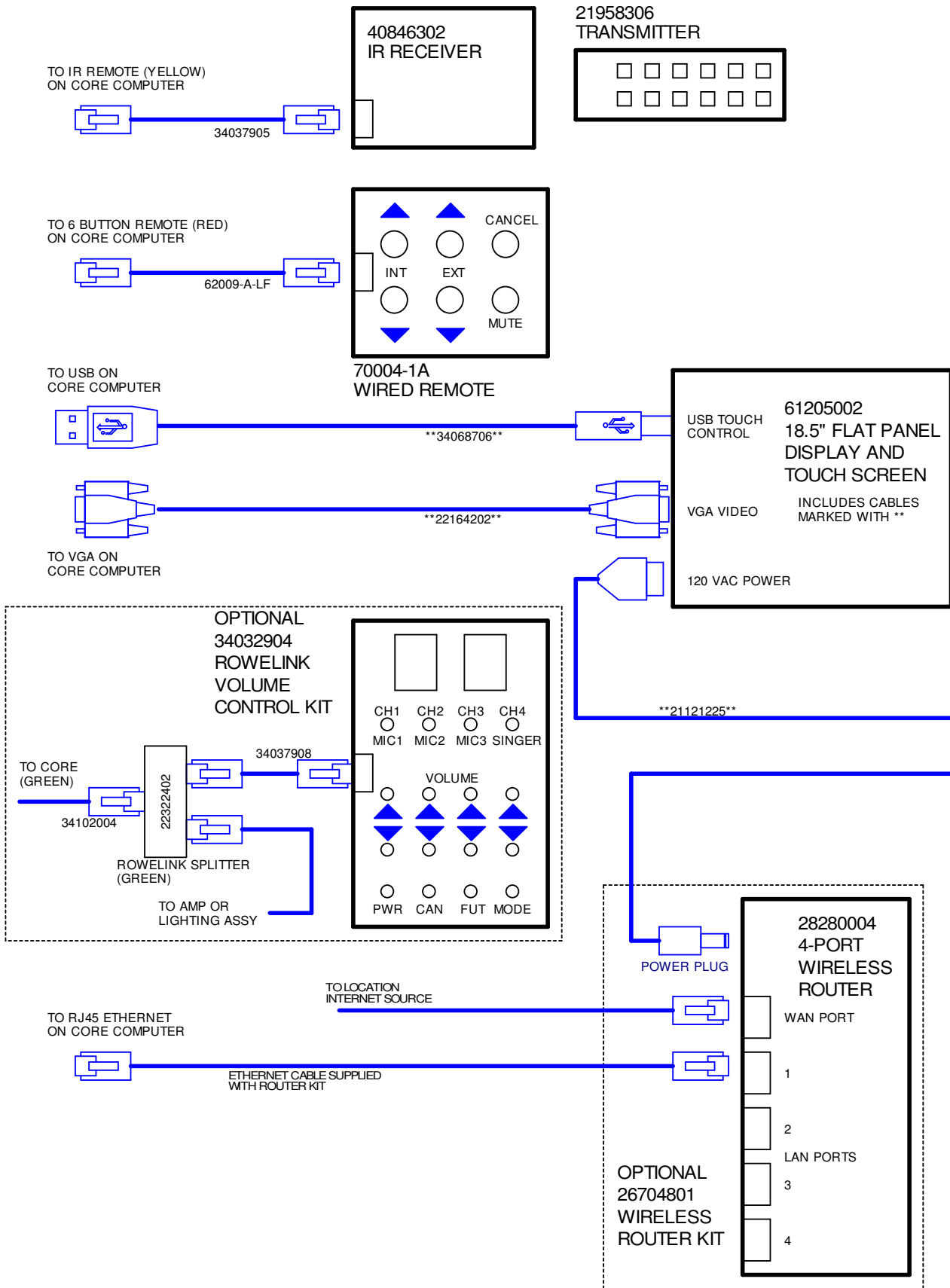

NGX MINI 2 WIRING DIAGRAM (PAGE 1)

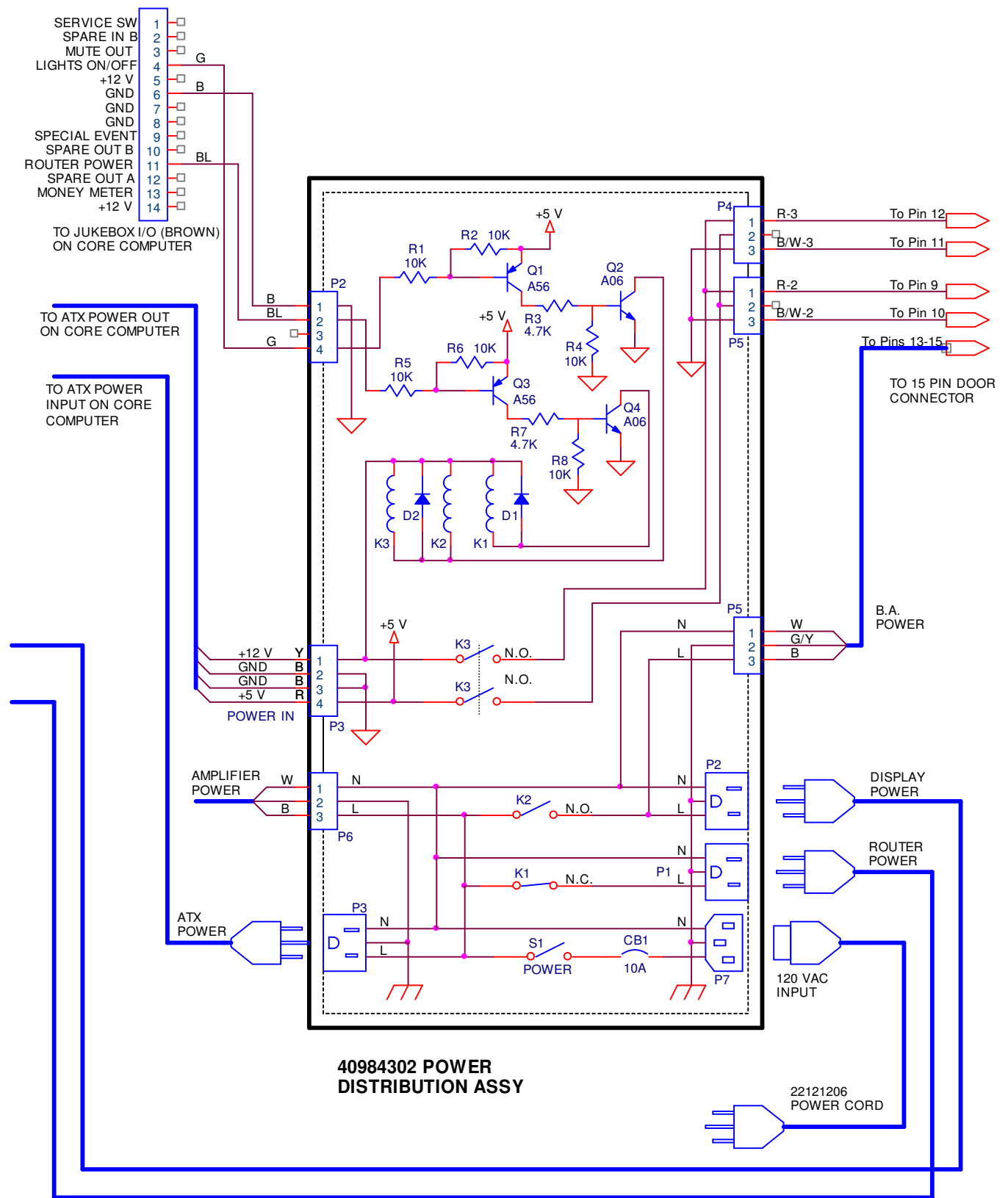

NGX MINI 2 WIRING DIAGRAM (PAGE 2)

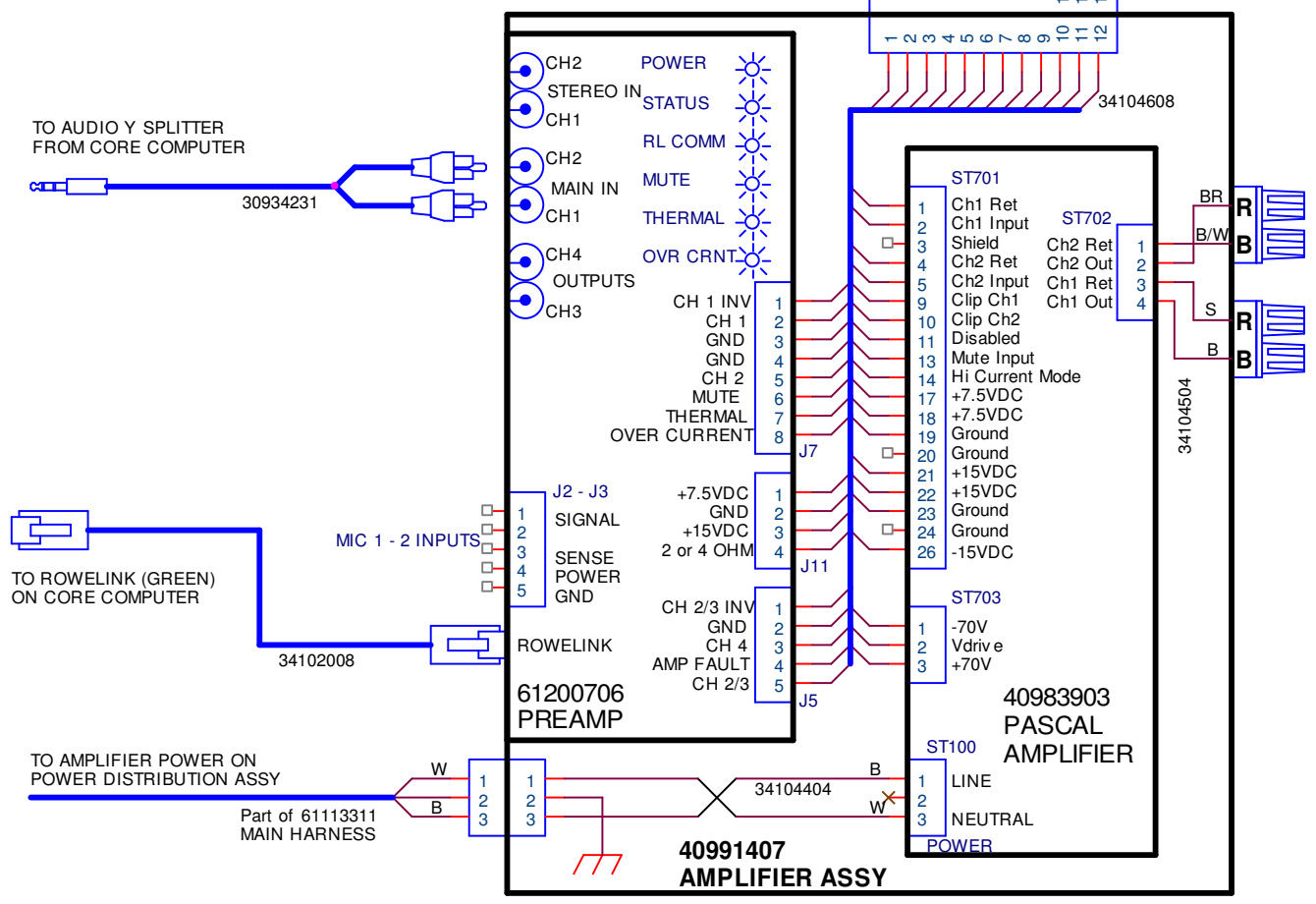
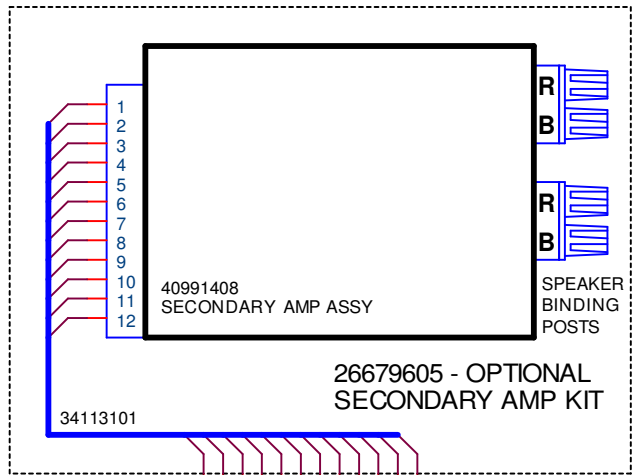
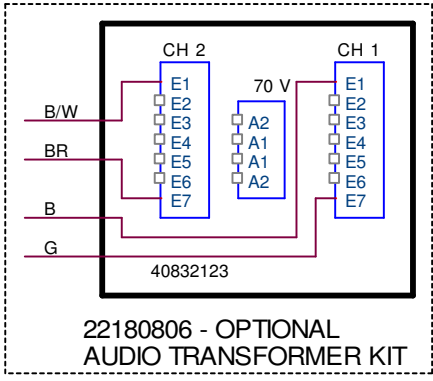
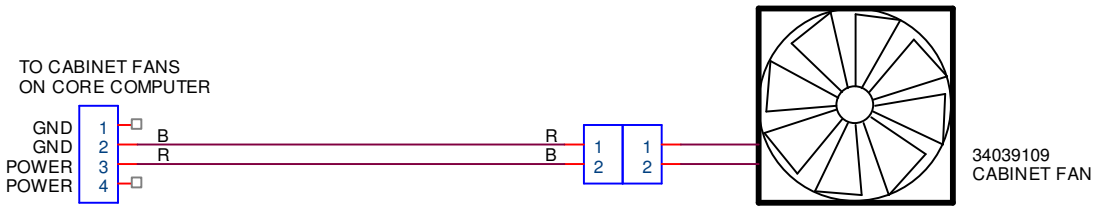

NGX MINI 2 WIRING DIAGRAM – SINGLE AMPLIFIER CONFIGURATION (PAGE 3)

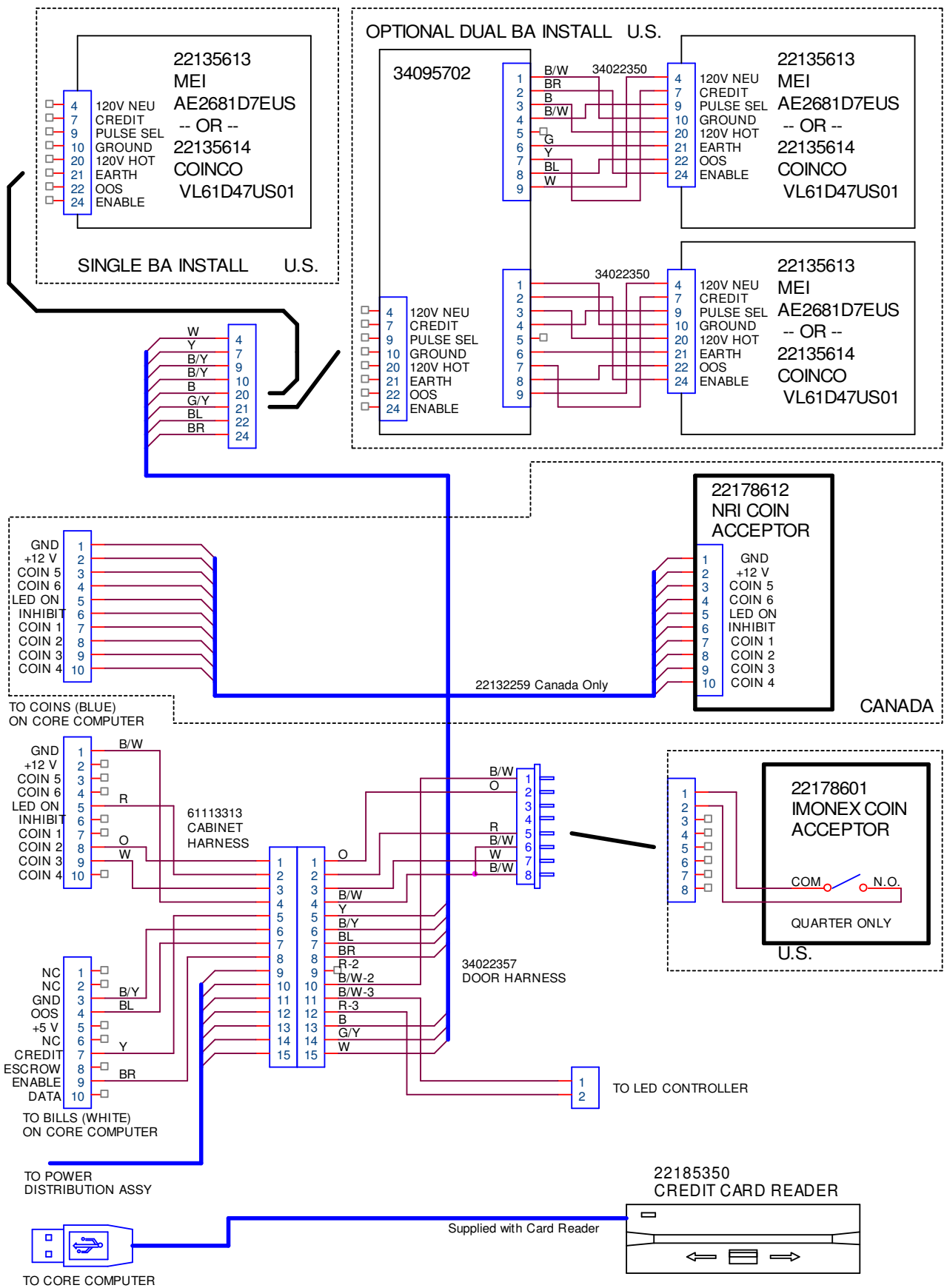

NGX MINI 2 WIRING DIAGRAM (PAGE 4)

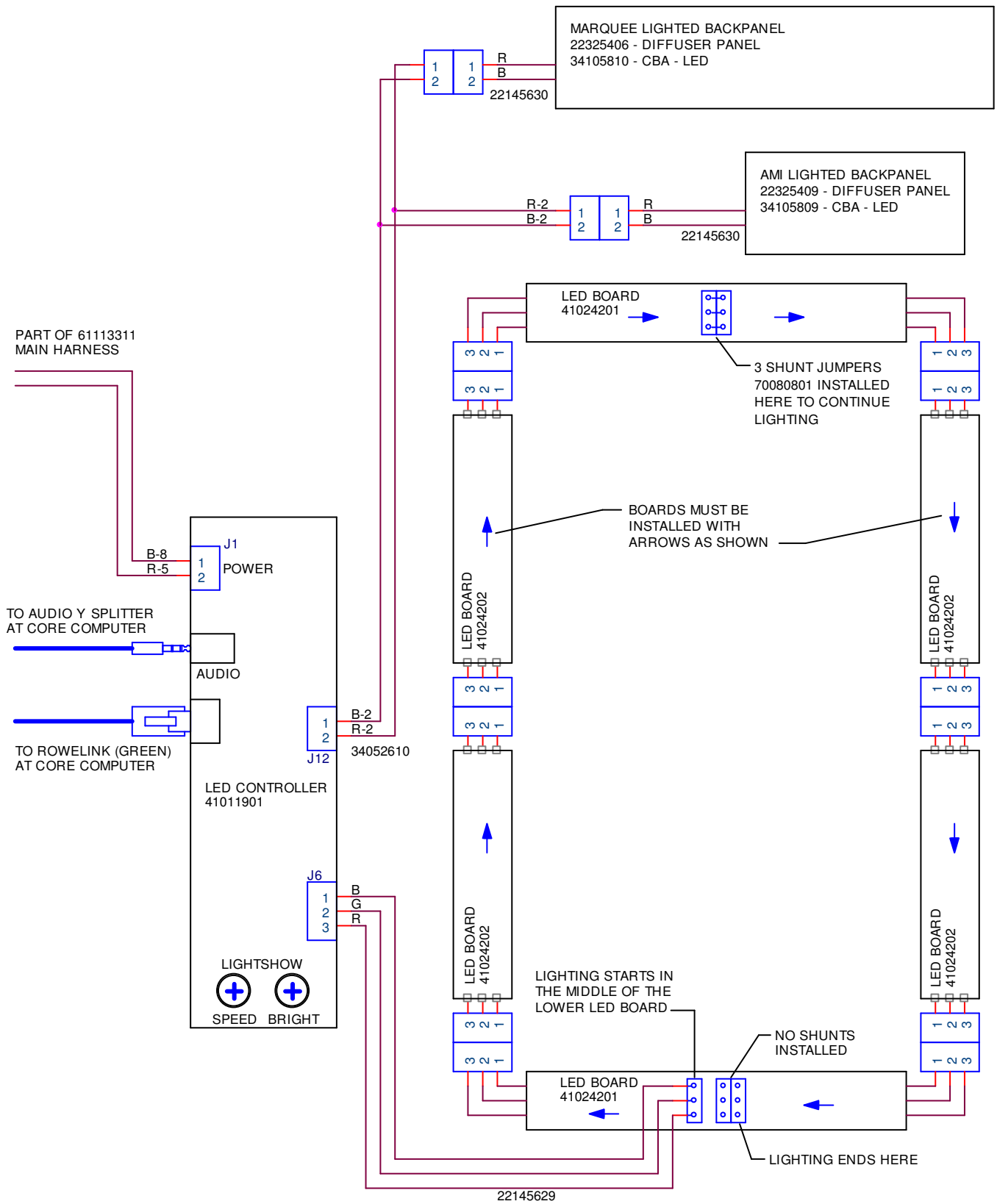

NGX MINI 2 WIRING DIAGRAM (PAGE 5)



*Section F -  
Parts Catalog*

- Front Door
  - Front Door Assembly
  - Frame and LED Lighting
- Inside Cabinet
- Currency Components
- Electronic Components
  - Computer Core
  - Power Supply
  - Amplifier Assembly
- Accessories

# Front Door

## Front Door Assembly

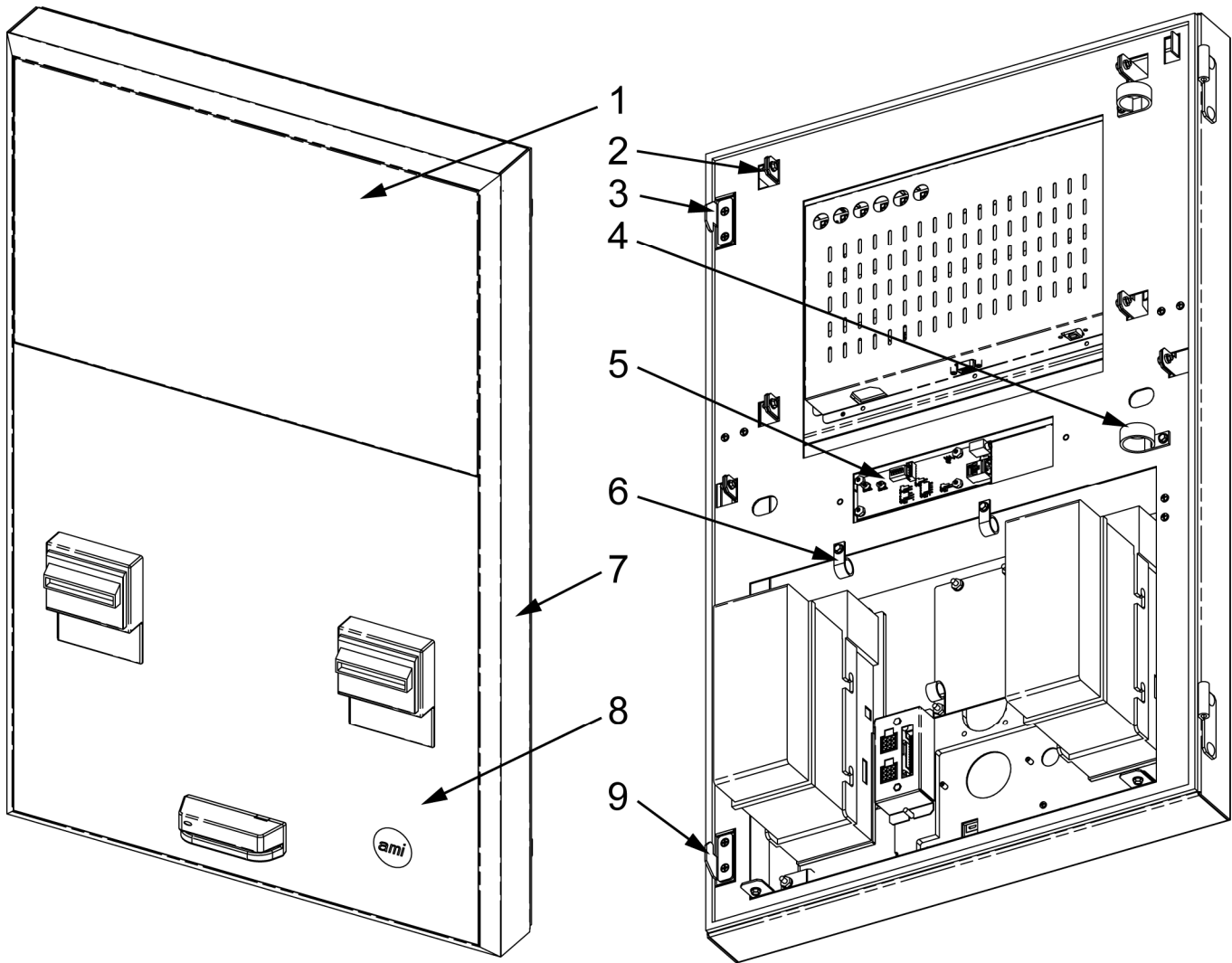

Ref.	Qty.	Part #	Description	Ref.	Qty.	Part #	Description
1	1	61205002	Display Assy-18.5" HD	4	2	70093403	Cable Clamp
1a	1	61210601	Touch Glass Sensor Assy	5	1	41011901	CBA-LED Controller, Mini 2
1b	1	40993902	Display Panel LCD 18.5"	6	2	70093402	Cable Clamp
1c	1	61205052	Power Supply	7		See page 37	Door Frame & LED Lighting
1d	1	61205061	Touch Controller	8		See page 39, 40	Currency Panel
1e	1	61194756	A/D Board	9	1	34103702	Catch-Bottom
1f	1	61194755	OSD Board				
1g	1	21121225	Power Cord	<b>Components not shown in assembly above</b>			
1h	1	22164202	Cable-VGA		1	34022357	Harness Assy-Door
1i	1	34068706	Cable-USB		1	22145629	Harness Assy-LED Lights
2	2	34115001	Bracket-Mounting		1	34052610	Harness Assy-Backlight Panels
3	1	34103701	Catch-Top		1	22145624	Harness Assy-LED Controller

# Front Door

## Frame and LED Lighting

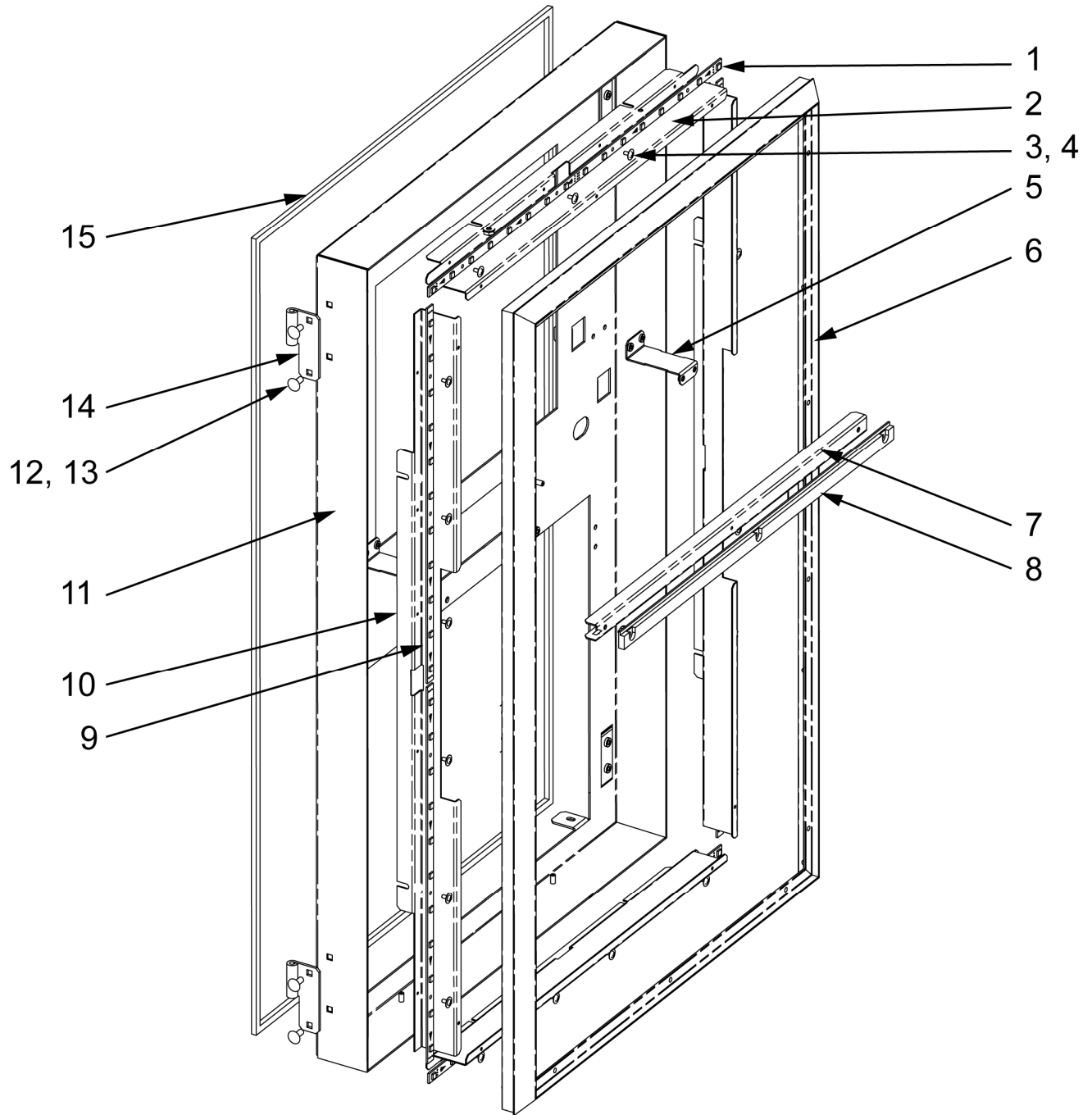

Ref	Qty	Part #	Description	Ref.	Qty.	Part #	Description
1	2	41024201	CBA-LED (Horiz)	9	4	41024202	CBA-LED (Vert)
2	2	34115201	Bracket-Mounting LED (Horiz)	10	2	35115401	Bracket-Mounting LED (Vert)
3	20	28277901	#M3x6mm PPHMS	11	1	61209801	Frame Assy-Door
4	20	70120511	Washer-Nylon	12	4	89974808	#10-32x1/2 Carriage Bolt
5	2	22339301	Bracket-Mounting-Diffuser	13	4	87844400	#10-32 KEPS Hex MS Nut
6	1	41023803	Diffuser	14	2	22323002	Hinge-Female
7	1	22339201	Bracket-Seam	15	8.4 Ft	00710206	Gasket-Foam Tape
8	1	22339101	Spacer Block-Seam				

# Inside Cabinet

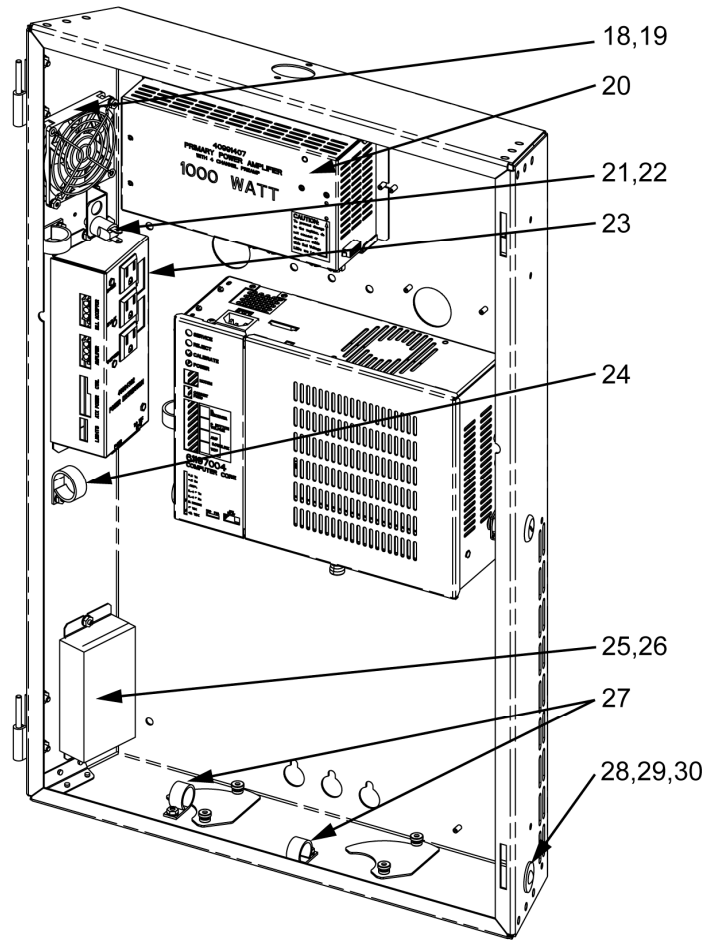
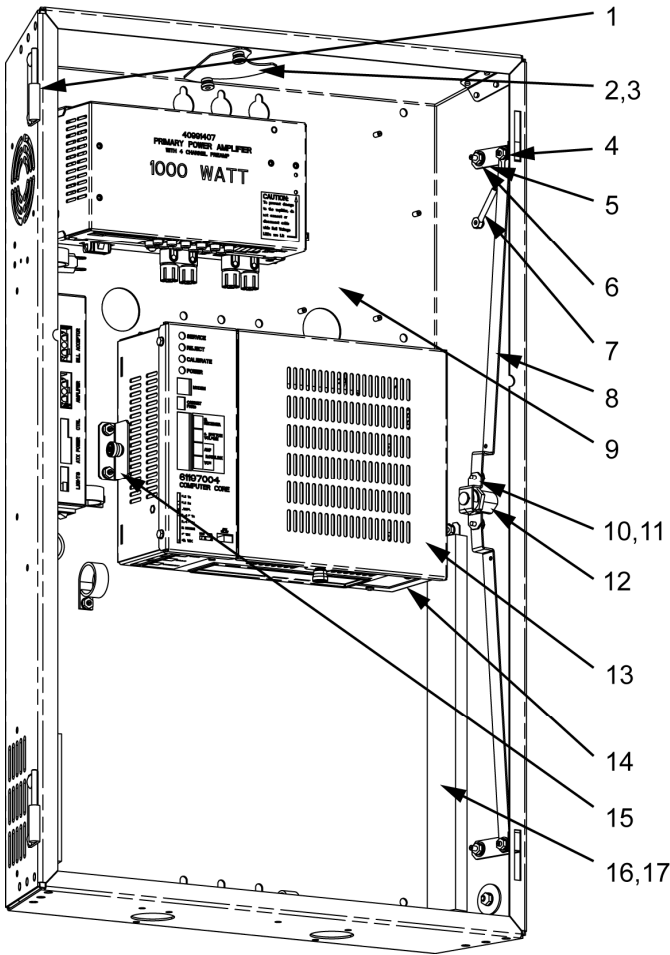

Ref.	Qty.	Part #	Description	Ref.	Qty.	Part #	Description
1	2	22323001	Male Hinge	20	1	40991407	1000-Watt Amplifier Assy.
2	3	34103501	Cord Hole Cover	21	1	22320601	Reset Bracket
3	6	22324201	8-32 Finger Nut	22	1	21581801	Push Button Switch
4	1	70091702	Solder Lug	23	1	40984302	Power Supply Assembly
5	2	22323101	Cabinet Latch	24	4	70093402	Cable Clamp
6	6	25156904	Shoulder Washer	25	1	34103603	Baffle – Short
7	1	21256201	Tension Spring	26	1	34053003	Air Filter – Short
8	2	34100601	Lock Actuator	27	2	70093401	Cable Clamp
9	1	61199503	Cabinet	28	1	89974808	#10-32 x ½ Carriage Bolt
10	1	34024501	Lock Bolt	29	1	87844400	#10-32 Keps Hex Nut
11	2	80443006	#8-32 x 3/8 Hex WHMS	30	2	70120926	Washer
12	1	70163215	Cylinder Lock	<b>Components not shown in assembly above:</b>			
13	1	61197004	Computer Core Assembly		1	61113311	Main Harness
14	1	22321601	Right Mounting Bracket		1	21121240	Power Cord
15	1	22321701	Left Mounting Bracket		1	30934235	Cable-Y Splitter, Stereo
16	1	34103602	Baffle - Long		1	30934236	Cable-Audio, Stereo 3.5mm
17	1	34053004	Air Filter – Long		1	34102005	Cable-Modular Rowelink (Green)(50")
18	1	34039109	Fan with Connector		1	34102008	Cable-Modular Rowelink (Green)(25")
19	1	21895503	Fan Finger Guard				

# Currency Components

## U.S. – Bill Acceptor, Card Reader, No Coin Acceptor

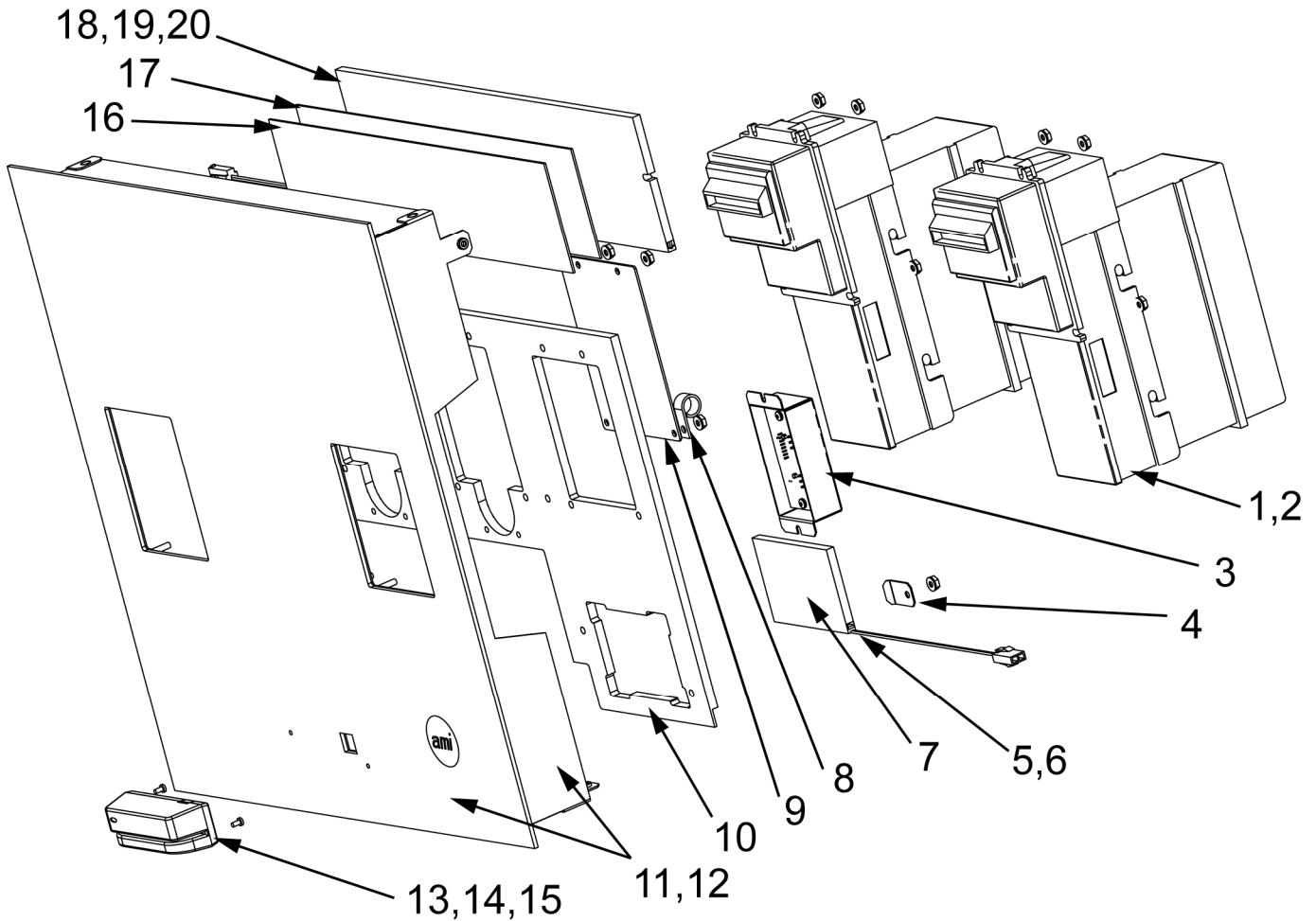

Ref	Qty	Part #	Description	Ref.	Qty.	Part #	Description
1	1or2	22135614	Coinco Bill Acceptor (US)	11	Note	41023303	Panel Assy-Dual BA, Card, No Coin
2	1or2	22135613	MEI Bill Acceptor (US)	12	Note	41023304	Panel Assy-Single BA, Card, No Coin
3	Note	34100002B	CBA & Cover Assy - Dual BA	13	1	22185350	Credit Card Reader
4	1	22339001	Clip-Retainer, Panel	14	1	PM0725-01	Credit Card Reader Label
5	1	34105809	CBA Backlight LED	15	2	28277903	#M3x16 PPHMS
6	1	22145630	Harness-LED Board	<b>These parts make up the backlit marquee</b>			
7	1	22325409	Panel-Lighting (AMI)	16	1	34114901	Panel-Graphic (BarLink)
8	1	70094301	Cable Clamp	17	1	34114903	Panel-Backer (Clear)
9	Note	34105104	Plate-Blocking	18	1	22325406	Panel-Lighting Marquee
10	1	41023401	Spacer-Currency Panel	19	1	34105810	CBA-Light Panel
				20	1	22145630	Harness-LED Board

Note: Item 3 – one used with Dual BA configuration.  
 Item 9 – one used on Dual BA configuration, two used on Single BA configuration.  
 Item 11 – one used on Dual BA configuration, Card Reader, no Coin Acceptor.  
 Item 12 – one used on Single BA configuration, Card Reader, no Coin Acceptor.

# Currency Components

## Non-U.S – with NRI Coin Acceptor (BA Ready)

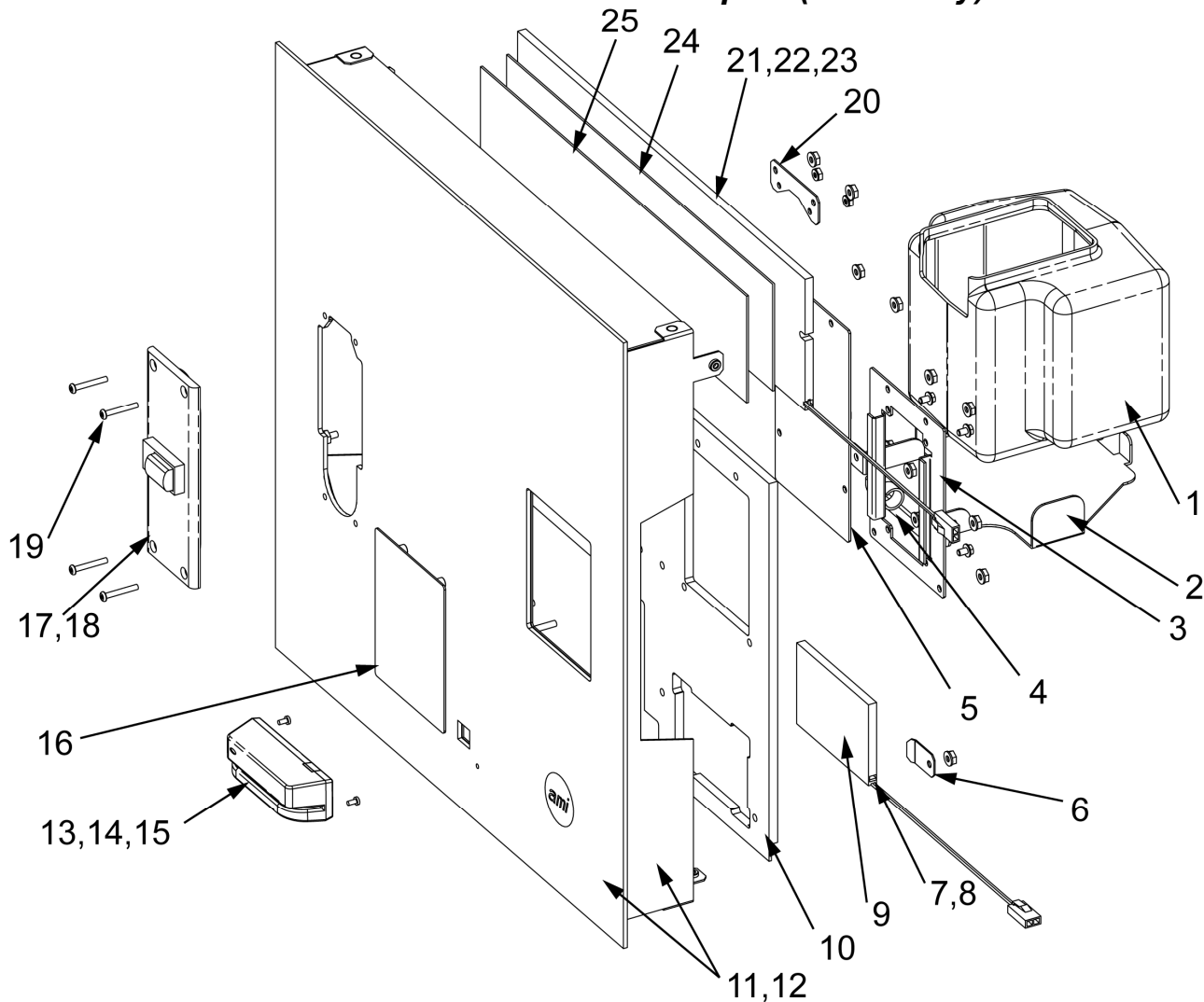

Ref	Qty	Part #	Description	Ref.	Qty.	Part #	Description
1	1	40990303	Coin Box	14	1	PM0725-01	Credit Card Reader Label
2	1	40992402	Retainer-Coin Box (Side Position)	15	2	28277903	#M3x16 PPHMS
3	1	34105101	Coin Mech Plate	16	1	34105103	Blockout-Bill Acceptor
4	1	70093401	Cable Clamp	17	1	See Note	Coin Acceptor
5	1	34105104	Plate-Blocking	18	1	22132259	Harness-Coin Mech, NRI
6	1	22339001	Clip-Retainer, Panel	19	4	70134153	#6-32x1 Pin-in-Torx Screw
7	1	34105809	CBA Backlight LED	20	1	22325101	Plate-Mounting NRI Coin Mech
8	1	22145630	Harness-LED Board	<b>These parts make up the backlit marquee</b>			
9	1	22325409	Panel-Lighting (AMI)	21	1	22325406	Panel-Lighting Marquee
10	1	41023401	Spacer-Currency Panel	22	1	34105810	CBA-Light Panel
11	Note	41023306	Panel Assy-Single BA, NRI Coin, Card	23	1	22145630	Harness-LED Board
12	Note	41023305	Panel Assy-Single BA, NRI Coin, No Card	24	1	34114903	Panel-Backer (Clear)
13	1	22185350	Credit Card Reader	25	1	34114901	Panel-Graphic (BarLink)

Note: Item 11 – one used on BA Ready configuration with NRI coin acceptor and card reader.  
 Item 12 – one used on BA Ready configuration with NRI coin acceptor, without card reader.  
 Item 17 – 22178603 South Africa      22178612 Canada  
           22178613 New Zealand      22178614 Australia  
           22178615 Euro

# Electronic Components

## Computer Core Assembly 61197004

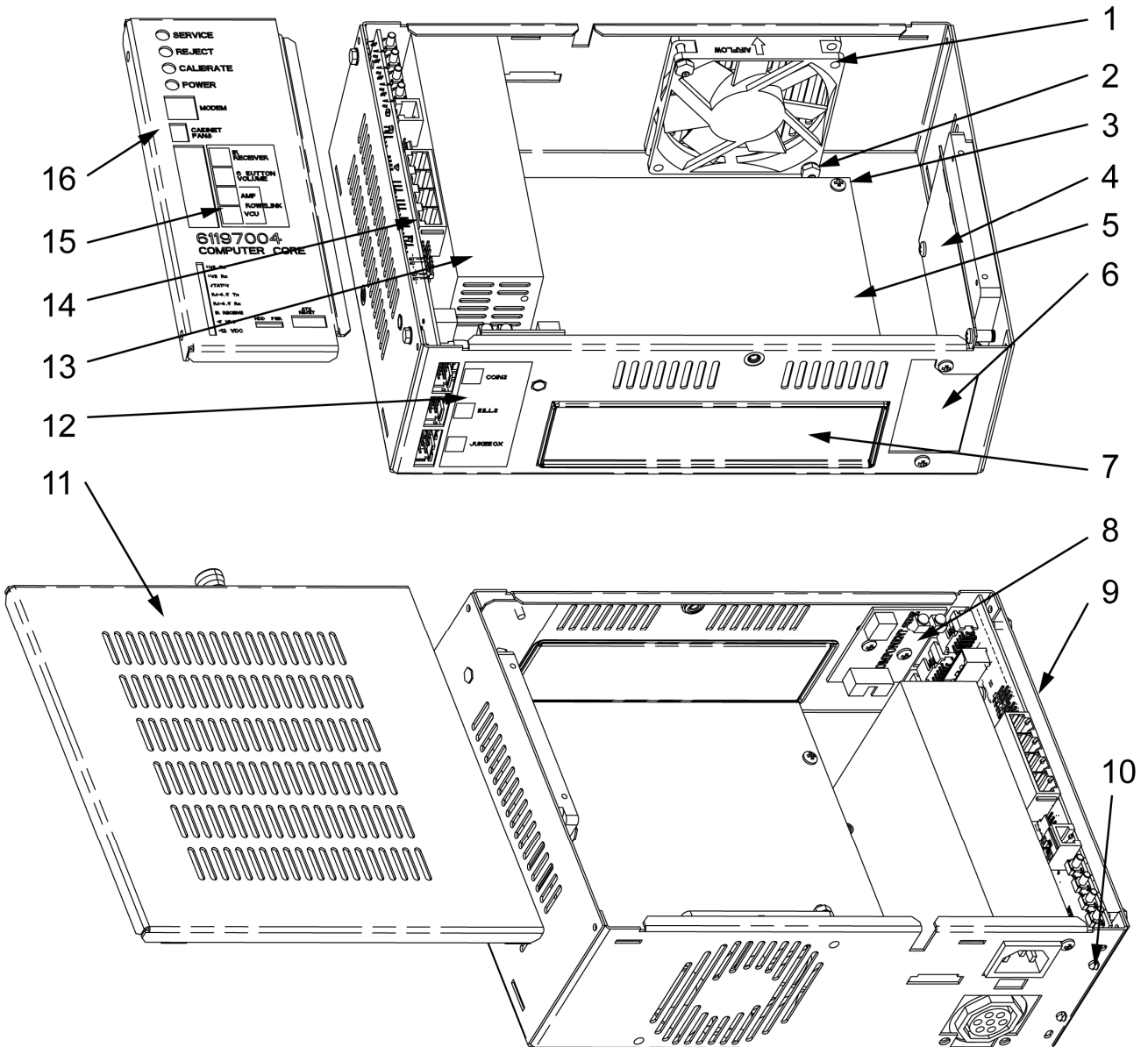

Ref.	Qty.	Part #	Description	Ref.	Qty.	Part #	Description
1	1	34039110	Fan – Chassis Cooling w/Tach	13	1	40952205	Power Supply
2	2	87842300	Nut - #6-32 Keps Hex	14	1	61196903	CBA – I/O Interface
3	15	80352304	#6-32x1/4 PPHMS	15	1	22167705	Label – Jukebox Connections
4	1	34101201	Bracket – Hard Drive Mounting	16	1	34101103	Cover – Small
5	1	40924214	Single Bd Computer Assy (B75B)	<b>Components not shown above</b>			
6	1	22328802	Bracket – PCI Modem Blockout		1	22132269	Harness Assy – Com I/O
7	1	40922699	I/O Shield (B75B)		1	22132270	Harness Assy – Power On/Reset
8	1	34052405	CBA – Power On/Reset		1	22132282	Cable – SATA Data
9	1	91197103	Housing – Core Computer				
10	1	22137302	Guide – Card				
11	1	40983503	Cover - Top	Ref	1	22219001	Hard Drive – System, US
12	1	22167704	Label – Computer Connections	Ref	1	22219002	Hard Drive – System, Canada

**Power Supply Assembly 40984302**

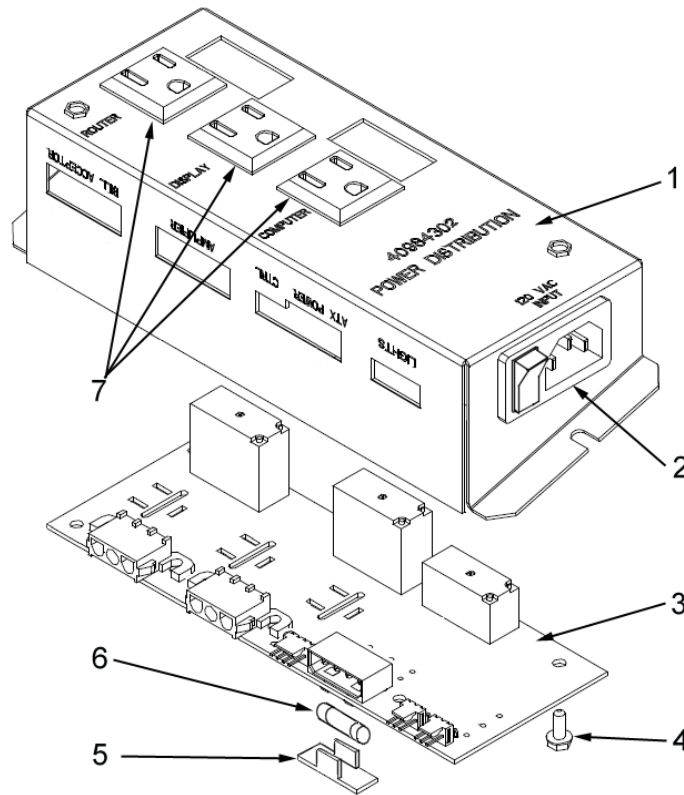

Ref.	Qty.	Part #	Description	Ref.	Qty.	Part #	Description
1	1	40984402	Power Supply Cover	5	1	25077506	Cover - Fuse Clip
2	1	22118707	Power Inlet/Switch	6	1	70072129	Fuse - 10A
3	1	40983802	Power Control CBA	7	3	21375905	Convenience Outlet
4	4	80352304	#6-32x1/4" Screw				

**Amplifier Assembly 40991407**

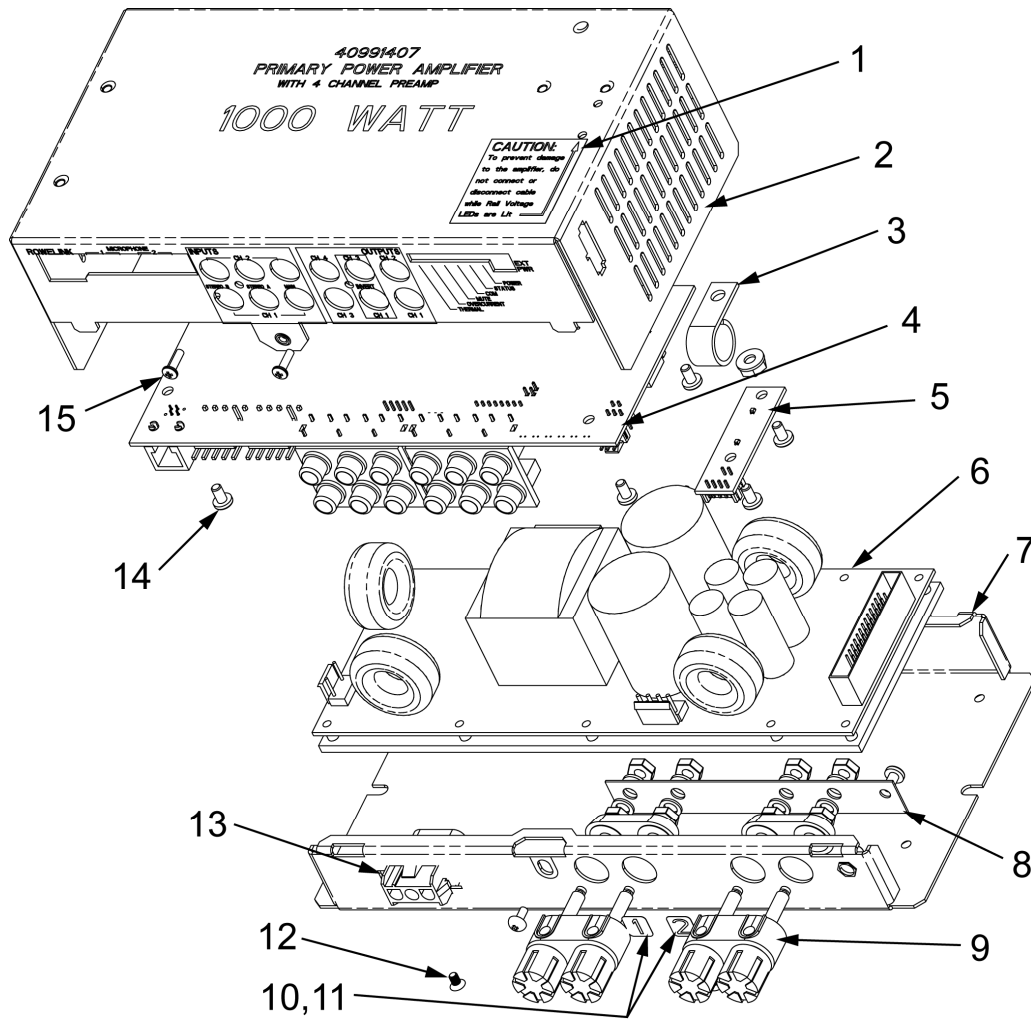

Ref.	Qty	Part #	Description
1	1	22167723	Label – Caution
2	1	61200311	Amplifier Cover
3	1	70093401	Clamp – Cable
4	1	61200706	CBA – 4-Channel Preamplifier
5	1	22337501	CBA – Rail Voltage LEDs
6	1	40983903	1000-Watt Amplifier
7	1	61200407	Amplifier Base
8	1	22337201	CBA – Output Decoupler
9	2	34104201	Dual Binding Post
10	1	22167717	Label – “1”
11	1	22167718	Label – “2”
12	6	28277904	#M3x5 Phil Flat Head Screw
13	1	34104404	Amp Power Harness
14	9	80342304	#6-32 1/4” Pan Head Screw
15	2	89281606	#4-24 x 3/8 Pan Head Screw
<b>Components not shown in diagram:</b>			
	1	34104608	Audio In Harness
	1	34104504	Audio Out Harness

## Accessories

Part Number	Description
22118916	<b>Handy Pack (contains the following):</b>
21958306	IR Transmitter
40846302	IR Receiver
34037905	IR Receiver Cable
21121216	Power Cord
70004-1A	2-Channel Remote Control
62009-A-LF	Remote Control Cable
34024502	Lock Bolt (Ace Lock)
22324601	Cable Retainer Bracket
<b>22200862</b>	<b>Small Parts Kit (contains the following):</b>
89986124 (4)	Screw, Lag 1/4 x 1-1/2" Hex Head
ST-11327 (2)	#8 x 1 1/2" Phillips Pan Head Screws for 2-Channel Remote

Optional Kits	
26704801	Kit – Router, Wireless
22180806	Kit – Output Transformers
22178504	Kit – Modem, Internal PCI-Ex
26682503	Kit – Money Meter
26681501	Kit – Special Event Switch
02468	Kit – Wireless, RF Remote Control
26679501	Kit – Paging with Cable
26679502	Kit – Paging w/o Cable
26679710	Kit – 2nd Bill Acceptor (parts only - Bill Acceptor not included)
26679711	Kit – 2nd Bill Acceptor (includes CoinCo Bill Acceptor)
26679712	Kit – 2nd Bill Acceptor (includes MEI Bill Acceptor)
26695501	Kit – NGX Video
26679605	Kit – Secondary Amplifier
26684705	Kit – Trackball ADA Compliant (Single BA)
26684704	Kit – Trackball ADA Compliant (Dual BA)

**Notes:**

---

