

PAC-MAN SMASH

Operation Manual

The actual product may differ slightly from the illustrations in this Operation Manual.

WARNING

- To ensure safe operation of the machine, be sure to read this Operation Manual before use.
- Keep this Operation Manual in a safe place for quick access whenever needed.

NAMCO BANDAI Games Inc.



Introduction

Thank you very much for purchasing PAC-MAN SMASH (referred to as “the machine” in this manual).

This Operation Manual describes:

- How to safely install, move, transport, operate, service and dispose of the machine.
- How to make full use of the machine’s functions and operate it correctly.
- How to ensure the safety of players and bystanders.

Contact for this machine and machine repair inquiries

- For inquiries regarding the machine or machine repairs, contact your distributor.





1. Safety Precautions

-Be sure to read to ensure safe operation-

- 1
- 2
- 3
- 4
- 5
- 6
- 7
- 8A
- 8B
- 9
- 10
- 11
- 12

Instructions to the Owner

If you delegate the work for installing, moving, transporting, operating, servicing or disposing the machine to other people, ensure that these people read the relevant sections of this operation manual carefully before starting work, and observe the corresponding precautions.

1-1 Levels of Risk

The safety and property damage precautions on the machine labels and in this Operation Manual are classified according to their risk level, as follows.

 **WARNING** : Failure to avoid these risks may result in serious injury or death.

 **CAUTION** : Failure to avoid these risks may result in light injury or damage to other property.

Notes about functionality that are not linked to safety are indicated with the following symbol.

 **NOTICE** : Information about product functions or protection.

1-2 Definition of "Technician"

This Operation Manual is designed for arcade personnel. However, the sections marked "Must be performed by a technician" in the Table of Contents are written for technicians. These tasks must be performed by technicians only.

Technician: A person involved in design, manufacture, inspection or service at an amusement device manufacturer, or a person involved routinely in the service or management (such as repair) of amusement devices and who has specialist knowledge of electricity, electronics or mechanical engineering equivalent to or higher than a technical high school graduate.

Levels of Risk / Definition of "Technician"

Test Mode

Troubleshooting

1-3 Critical Safety Precautions

WARNING

- Should an abnormality occur, turn off the power switch immediately to stop operations. Then, be sure to disconnect the power cord plug from the outlet. Operating the machine while the abnormality persists may result in a fire or accident.
- This machine includes important parts used to ensure the safety of players and bystanders. Operating the machine while these “important parts for ensuring player and bystander safety” are broken, damaged or deteriorated, or with defective installation may result in an injury to the players or bystanders. If you discover an abnormality, replace the affected part immediately. To order parts, contact your distributor.
- Dust accumulating on the power cord plug may result in a fire. Inspect the plug regularly and remove any dust.
- Fully insert the power cord plug into the outlet. Poor contact may generate heat and result in a fire or burns.
- Damage to the power cord may result in a fire, electric shock or electrical leakage. Be sure to observe the following.
 - Keep the power cord away from heaters.
 - Do not twist the power cord.
 - Do not forcibly bend the power cord.
 - Do not alter the power cord.
 - Do not pull the power cord. (Always unplug by holding the plug and not the power cord.)
 - Do not bundle the power cord.
 - Do not place objects on the power cord.
 - Do not allow the power cord to be caught between the machine and other devices or the wall.
 - Do not do anything else that might damage the power cord.
- Do not expose the power cord and power cord plug to water. It may result in electric shock or electrical leakage.
- Do not touch the power cord plug with wet hands. It may result in electric shock.
- The power capacity of the machine is AC 120 V (or 220 V), maximum current consumption 3 A. To prevent fire and electric shock, use indoor wiring that conforms to these power supply specifications.
- Use a power supply voltage range of AC 110 V to 130 V (or 210 V to 230 V). Using a voltage outside this range may result in a fire or electric shock. However, to ensure that the machine operates in the optimum condition, keep the voltage at AC 120 V (or 220 V) as much as possible.
- To ensure safe use of the machine, be sure to perform the pre-operation inspection (See “7-4 Pre-operation Inspection” on page 35.) and service (See “8B Service” on page 109.). Omitting these inspections or service may result in an accident.
- Use the consumables and service parts (including screws) that are specified by NAMCO BANDAI Games Inc. To order parts, contact your distributor.
- Do not modify the machine without permission. Do not perform any operations that are not described in this Operation Manual. Modifying the machine may create unforeseen hazards.
- If you decide to transfer ownership of this machine, be sure to provide this Operation Manual with the machine.

1-4 Machine Warning Labels

! WARNING

- The warning labels attached to the machine contain important information for ensuring safety. Be sure to observe the following.
 - To ensure that the warning labels attached to the machine are always clearly visible, install the machine in an appropriate location with ample illumination and keep the labels clean at all times. Make sure that the labels are not hidden by other machines or objects.
 - Do not remove or alter the warning labels.
 - If a warning label becomes excessively dirty or damaged, replace it with a new one. To order warning labels, contact your distributor.

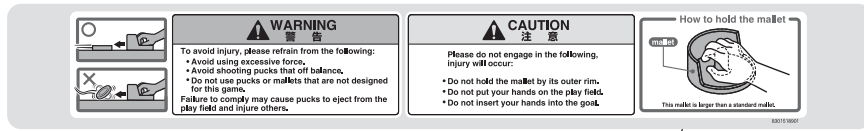

Warning sticker Goal (blue)
Part No.: 461-768

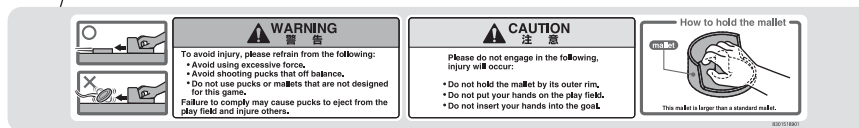
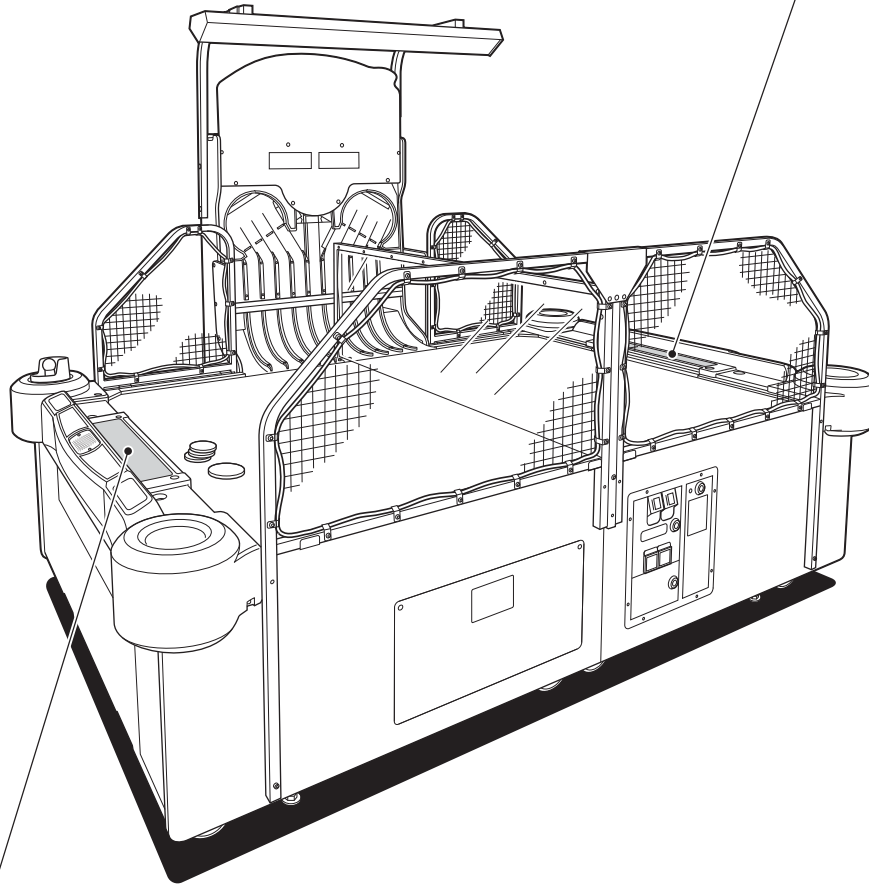

Warning sticker Goal (red)
Part No.: 461-769

- 1
- 2
- 3
- 4
- 5
- 6
- 7
- 8A
- 8B
- 9
- 10
- 11
- 12

Critical Safety Precautions / Machine Warning Labels

- Test Mode
- Troubleshooting

1. Safety Precautions -Be sure to read to ensure safe operation-

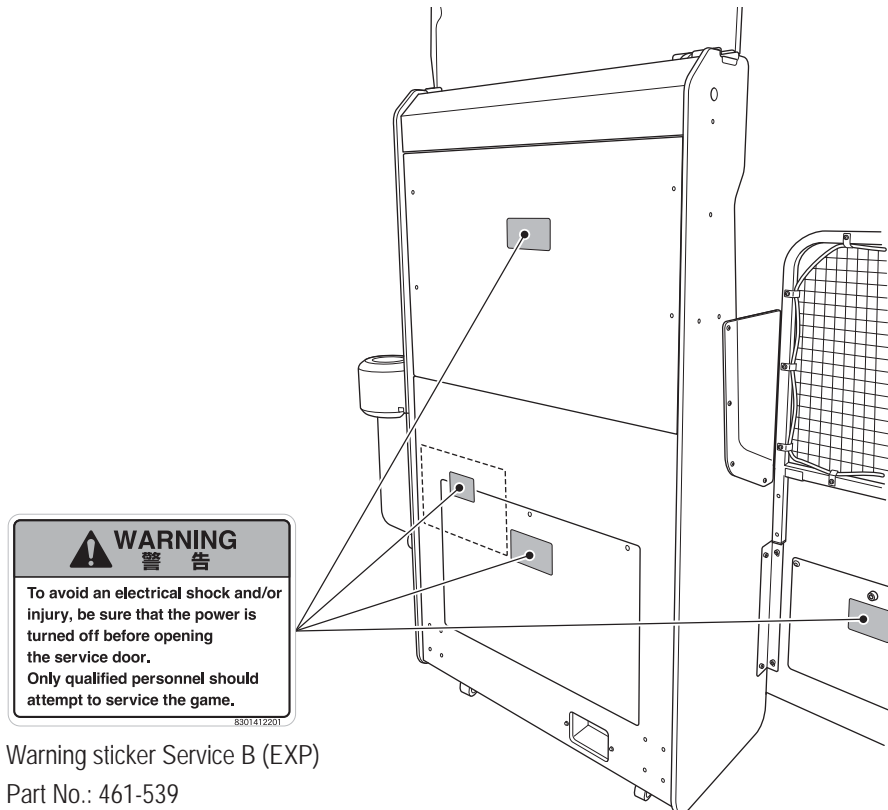
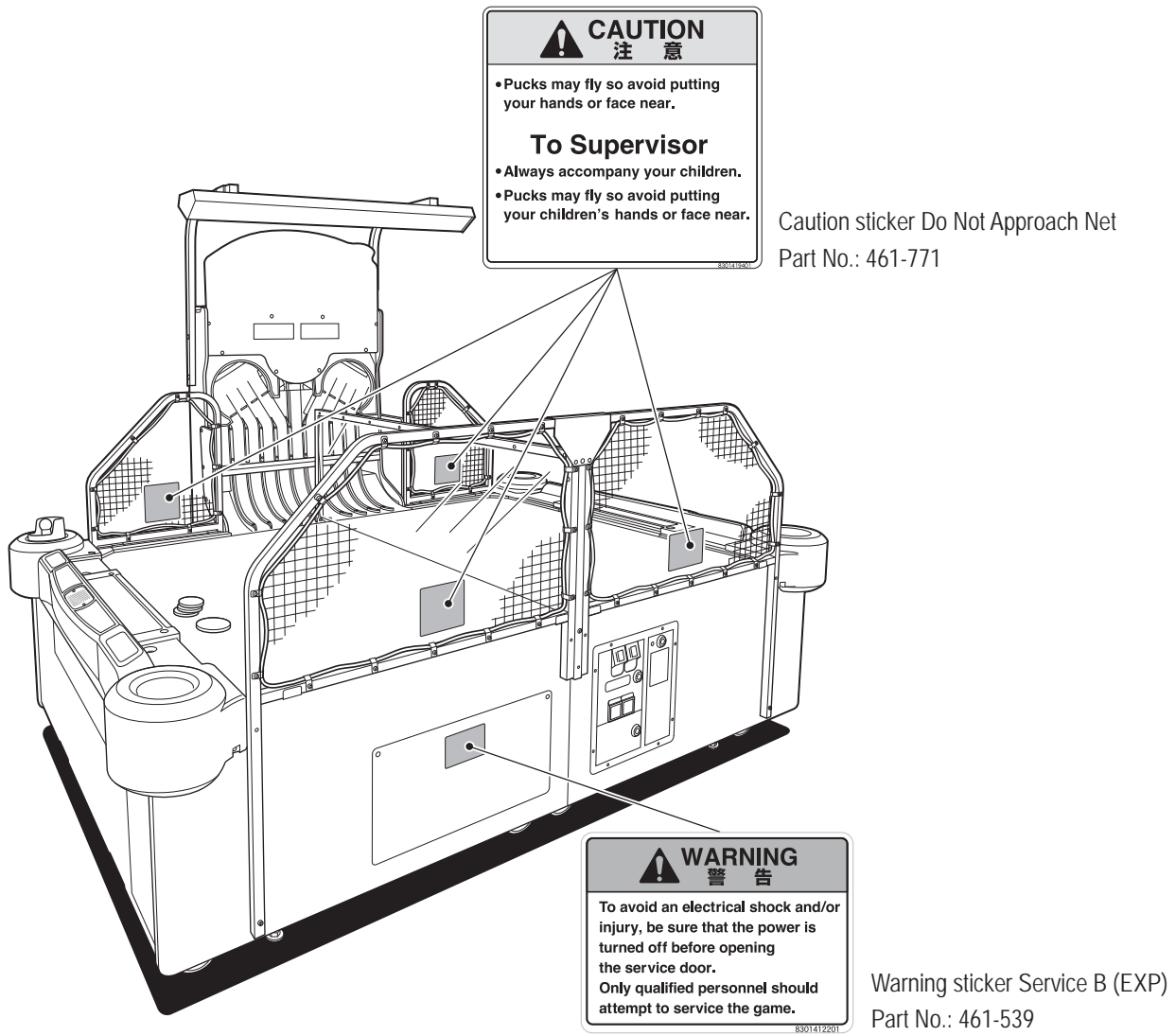

1. Safety Precautions -Be sure to read to ensure safe operation-

(When transporting the side tower cabinet)

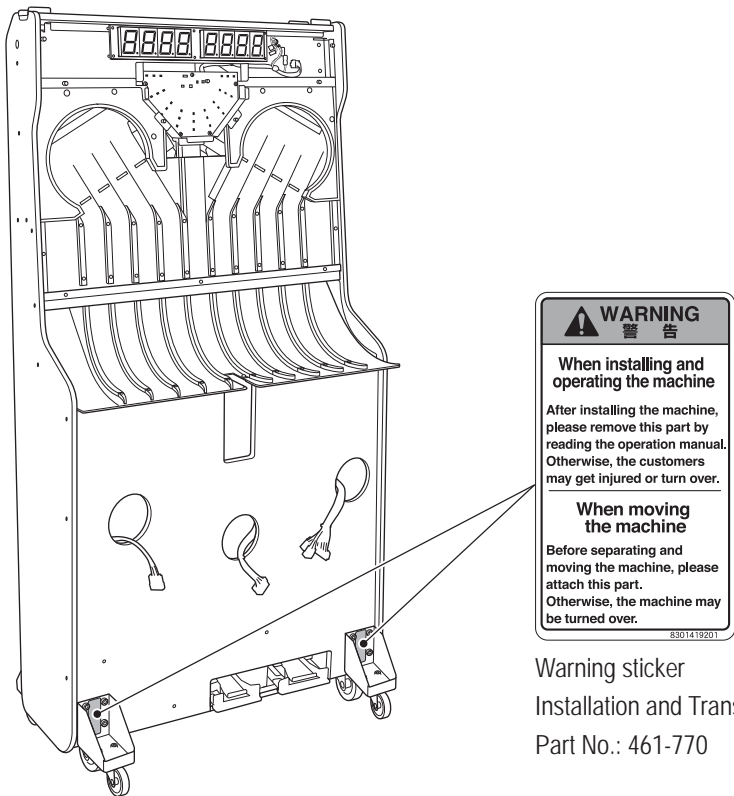
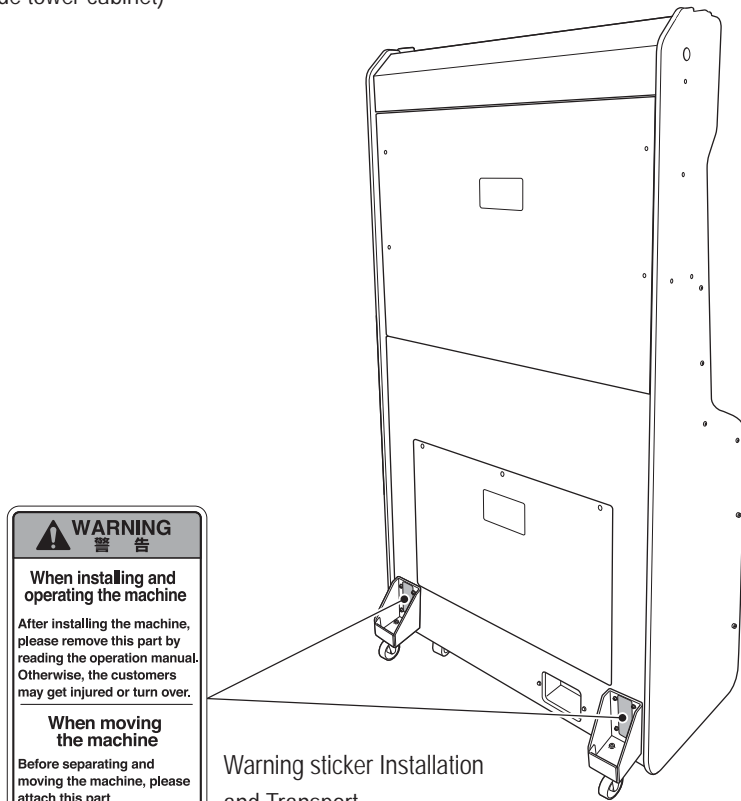

- 1
- 2
- 3
- 4
- 5
- 6
- 7
- 8A
- 8B
- 9
- 10
- 11
- 12

Machine Warning Labels

Test Mode

Troubleshooting

Table of Contents

Introduction

1. Safety Precautions -Be sure to read to ensure safe operation-	1
1-1 Levels of Risk	1
1-2 Definition of "Technician"	1
1-3 Critical Safety Precautions	2
1-4 Machine Warning Labels	3
2. Specifications	10
3. Package Contents	13
4. Overall Structure (Part Names)	22
5. Installation	24
5-1 Installation Conditions	24
5-1-1 Installation Locations to Avoid	24
5-1-2 Play Zone for the Installed Machine	25
5-2 Required Dimensions for the Delivery Route (Such as Doors and Corridors)	26
6. Moving and transporting	27
6-1 Moving (On the Same Floor)	27
6-2 Transporting	28
6-2-1 Transporting Manually (Such as Carrying on Stairs)	28
6-2-2 Loading and Unloading to and from a Vehicle	30
6-2-3 Transporting on a Vehicle	31
7. Operation	32
7-1 People Who Should Avoid Playing	33
7-2 Safety Precautions for Playing	33
7-3 Important Parts for Ensuring Player and Bystander Safety	34
7-4 Pre-operation Inspection	35
7-4-1 Safety Inspection Items (Before Power On)	35
7-4-2 Function Inspection Items (After Power On)	36
7-5 Opening and Closing Doors	37
7-5-1 Opening and Closing the Selector Door	37
7-5-2 Opening and Closing the Coin Box Door	37
7-5-3 Opening and Closing the Goal (L) and (R) Assemblies	38
7-6 Explanation of the Power Switch and Adjustment Switches	39
7-6-1 Turning the Power Switch On	39
7-6-2 Adjustment Switches	39
7-7 Playing the Game	40
7-7-1 Starting the Game and Game End	40
7-8 Test Mode	41
7-8-1 Test Item Selection Mode	41
7-8-2 Score LED, Time LED and Circle LED Test	42
7-8-3 Switch Input Test	43
7-8-4 Blower Fan ON/OFF Test and Sensor Check	45
7-8-5 Solenoid ON/OFF Test and Sensor Check	46
7-8-6 L Hopper Motor ON/OFF Test and Sensor Check	47
7-8-7 S Hopper Motor ON/OFF Test and Sensor Check	48
7-8-8 Sound Test	49
7-8-9 Ticket Dispenser Test	50
7-9 Setting Mode	51
7-9-1 Setting Item Selection Mode	51



Table of Contents

<hr/>	
7-9-2	Number of coins per game.....53
7-9-3	Number of plays per game.....54
7-9-4	Big Bang Mode play time55
7-9-5	Normal Hockey Mode play time56
7-9-6	Mini puck supply frequency more/less setting for Big Bang Mode.....57
7-9-7	3-puck setting for Normal Hockey Mode.....58
7-9-8	Attract BGM ON/OFF59
7-9-9	Mini puck low warning ON/OFF60
7-9-10	Error log61
	(1) Number of Errors Saved in Error Log Display Mode61
	(2) Error Log Contents Display Mode62
7-9-11	Ticket Dispenser Use Setting.....63
7-9-12	Number of Tickets Paid to Winner64
7-9-13	Number of Tickets Paid to Loser.....65
7-9-14	Number of Tickets Paid in case of a Tie66
7-9-15	Game mode setting.....67
7-9-16	Return all settings to default settings (factory settings)68
7-10	Mini Puck Low Warning and Adding Mini Pucks.....69
7-10-1	Mini Puck Low Warning.....69
7-10-2	Adding Mini Pucks69
7-11	Daily Cleaning70
7-11-1	Cleaning the Playing Field70
7-11-2	Cleaning the Goal Covers and Corner Covers71
7-11-3	Cleaning the Pucks and Mallets.....71
7-11-4	Cleaning the Signboard and Cover Panel.....72
7-11-5	Cleaning the Sloped Areas73
8.	Technician's Manual - Must be performed by a technician -.....74
8A.	Installation and Assembly.....74
8A-1	Number of Workers, Work Time and Work Space.....74
8A-1-1	Number of Workers and Work Time.....74
	(1) Number of Workers74
	(2) Work Time74
8A-1-2	Securing Work Space74
8A-2	Assembly.....75
8A-2-1	Assembling the Table.....75
	(1) Assembling the Table, Goals and Corner Covers.....75
	(2) Installing the Nets.....86
	(3) Installing the Blower Fan89
8A-2-2	Level Adjuster Adjustment.....90
8A-2-3	Assembling the Side Tower Assembly91
8A-2-4	Installing the Light Assembly.....94
8A-2-5	Installing the Side Tower Assembly.....96
8A-2-6	Preparing the Pucks and Mallets105
8A-3	Connecting the Power Cord and Ground106
8A-4	Checks after Installation106
8A-5	Opening and Closing Doors107
8A-5-1	Opening and Closing the Front Doors107
8A-5-2	Opening and Closing the Service Doors L and R107
8A-5-3	Opening and Closing the Rear Panel108

- 1
- 2
- 3
- 4
- 5
- 6
- 7
- 8A
- 8B
- 9
- 10
- 11
- 12

Test Mode

Troubleshooting

Table of Contents

8A-5-4	Opening and Closing the Service Door.....	108
8B.	Service - Must be performed by a technician -	109
8B-1	Inspection and Service	109
8B-1-1	Inspection Items.....	109
8B-1-2	Cleaning the Puck Paths.....	110
	(1) Cleaning the Insides of the Goal (L) and (R) Assemblies.....	110
	(2) Cleaning the Rail (L) and (R) Assemblies.....	111
	(3) Cleaning the Insides of the L and S Buckets (Hopper Assembly)	112
	(4) Cleaning the Hopper Disks and Hopper Bottoms (Hopper Assembly)	113
	(5) Cleaning the S Slider Assembly	116
8B-1-3	Removing Jammed Pucks	118
	(1) Inside the Goal (L) or (R) Assembly	118
	(2) In case of the rail (L)/(R) assembly.....	118
	(3) Inside the Corner Rail (L) or (R)	119
	(4) Inside the L or S Bucket (Hopper Assembly)	120
	(5) Inside a Hopper Disk or Hopper Bottom (Hopper Assembly)	120
	(6) In case of S Escalator Assembly	121
	(7) In case of L Escalator Assembly.....	122
	(8) In case of the Slider Assembly	123
8B-1-4	Adding Big Pucks.....	124
8B-2	Error Display (for Technicians).....	125
8B-2-1	Display when an Error Occurs	125
8B-2-2	Resolving Errors	125
8B-3	Troubleshooting.....	130
8B-3-1	Overall.....	131
8B-3-2	Table top assembly	131
8B-3-3	Goal (L) and (R) Assemblies.....	132
8B-3-4	Rail (L) and (R) Assemblies	132
8B-3-5	Coin Assembly	132
8B-3-6	Hopper assembly	133
8B-3-7	Slider Assembly	134
8B-3-8	S Escalator Assembly	134
8B-3-9	L Escalator assembly.....	134
8B-3-10	Signboard assembly	135
8B-3-11	Illuminator assembly	135
8B-4	Removing, Installing and Replacing Assemblies and Parts.....	136
8B-4-1	Table	136
	(1) Removing and Installing the Goal (L) and (R) Assemblies	136
	(2) Removing and Installing the Rail (L) and (R) Assemblies	138
	(3) Replacing the Blower Fan	139
8B-4-2	Goal (L) and (R) Assemblies.....	141
	(1) Replacing the Goal (L) and (R) Sensors (Photosensor Side) and (Photo-emitter Side)	141
8B-4-3	Rail (L) and (R) Assemblies	142
	(1) Replacing the Rail (L) and (R) Sensors (Upper) and (Middle).....	142
	(2) Replacing the Rail (L) and (R) Sensors (Lower).....	144
8B-4-4	Side tower assembly.....	145
	(1) Removing and Installing the Side Tower Assembly	145
	(2) Replacing the Main PC Board	146
	(3) Replacing the Switching Regulator.....	148
	(4) Replacing the SSR	149



Table of Contents

<hr/>	
8B-4-5 Hopper assembly	150
(1) Replacing the L Hopper Motor	150
(2) Replacing the L Hopper Motor Sensor	154
(3) Replacing the S Hopper Motor	155
(4) Replacing the S Hopper Motor Sensor	158
(5) Replacing the S Hopper Motor Driver PC Board	159
8B-4-6 Slider Assembly	161
(1) Replacing the Stopper Solenoids (L) and (R)	161
(2) Replacing the Stopper (L) and (R) Sensors	163
8B-4-7 S escalator Assembly	164
(1) Replacing the S divider (L) and (R) Outlet Sensors	164
8B-4-8 L escalator assembly	165
(1) Replacing the L divider Solenoid	165
(2) Replacing the L divider Sensor	166
(3) Replacing the L divider (L) and (R) Outlet Sensors	167
8B-4-9 Signboard assembly	168
(1) Replacing the Time LED (Time LED PC Board)	168
(2) Replacing the Score LED (Score LED PC Board)	169
8B-4-10 Illuminator assembly	170
(1) Replacing the Circle LED	170
8B-4-11 Replacing the LED Fluorescent Light	173
9. Disposal	174
10. Parts List	176
10-1 Overall	176
10-2 Table top assembly	178
10-3 Cabinet (L) assembly	180
10-4 Goal (L) assembly	182
10-5 Rail (L) assembly	184
10-6 Cabinet (R) assembly	185
10-7 Goal (R) assembly	187
10-8 Rail (R) assembly	190
10-9 Side tower assembly	191
10-10 Hopper assembly	194
10-11 Slider assembly	198
10-12 S escalator assembly	200
10-13 L escalator assembly	202
10-14 Signboard assembly	204
10-15 Switch plate assembly	204
10-16 Illuminator assembly	205
10-17 Light Assembly	206
11. Wiring Diagram	207

- 1
- 2
- 3
- 4
- 5
- 6
- 7
- 8A
- 8B
- 9
- 10
- 11
- 12

Test Mode

Troubleshooting

2. Specifications

(1) Rated power supply	AC 120 \pm 10 V (50/60 Hz), AC 220 \pm 10 V (50/60 Hz)
(2) Rated power consumption	310 W
(3) Maximum current consumption	3 A
(4) Cashbox capacity	Approx. 200,000 yen (2,000 100 yen coins)
(5) Dimensions	
1) When installed	Width (W) 2,030 x Depth (D) 2,570 x Height (H) 2,170 [mm]

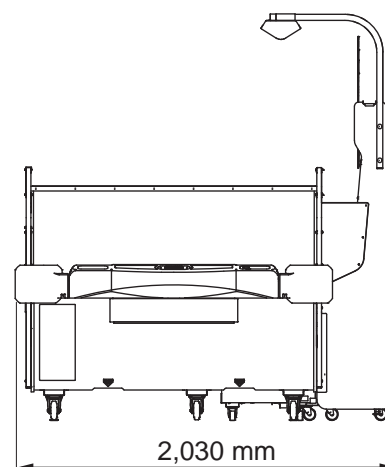
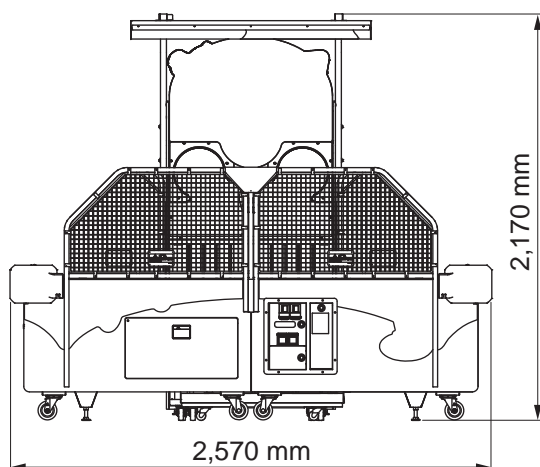
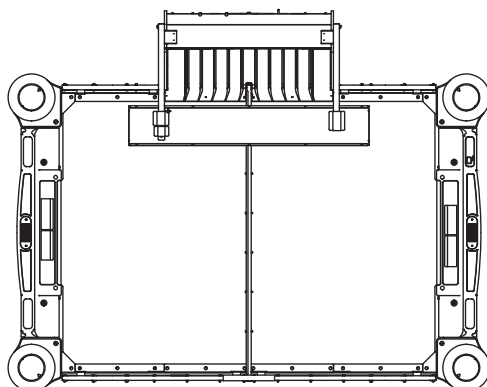

2) When disassembled

Table

Width (W) 1,690 x Depth (D) 2,570 x Height (H) 1,350 [mm]

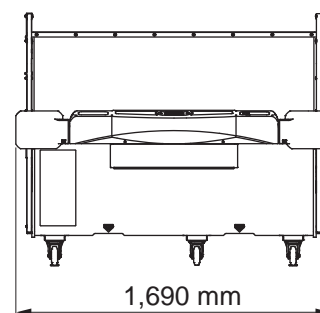
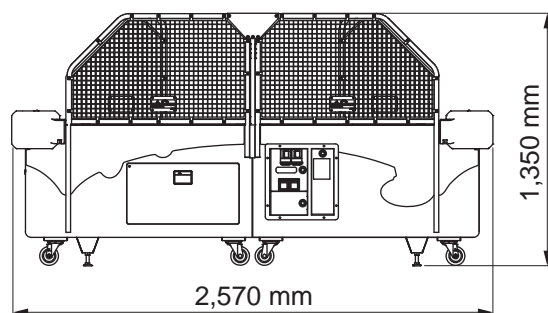



2. Specifications

- 1
- 2
- 3
- 4
- 5
- 6
- 7
- 8A
- 8B
- 9
- 10
- 11
- 12

Specifications

Table top assembly

Width (W) 1,490 x Depth (D) 2,080 x Height (H) 120 [mm]

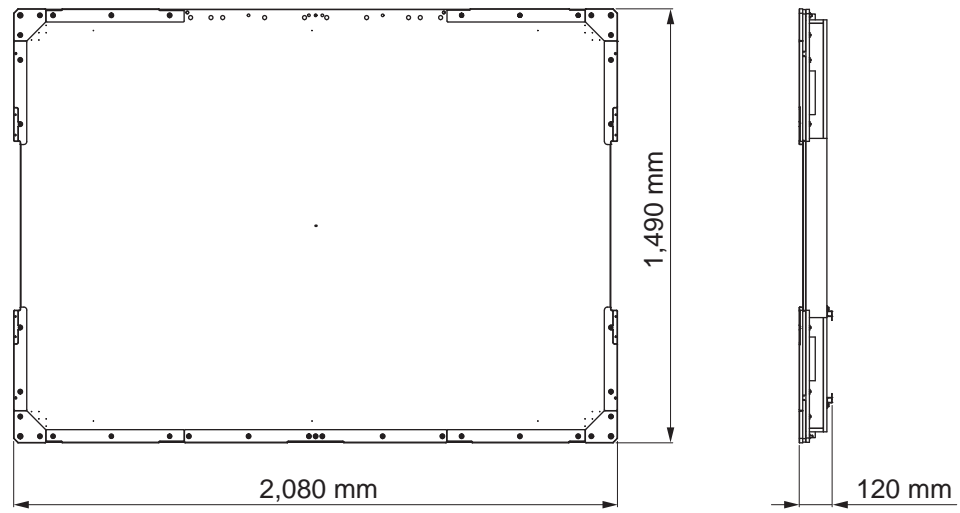

Cabinet (L) assembly

Width (W) 1,530 x Depth (D) 1,240 x Height (H) 840 [mm]

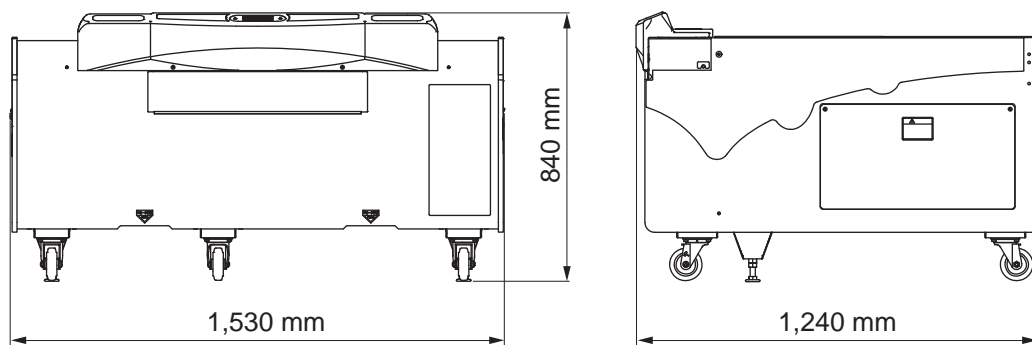

Cabinet (R) assembly

Width (W) 1,530 x Depth (D) 1,240 x Height (H) 840 [mm]

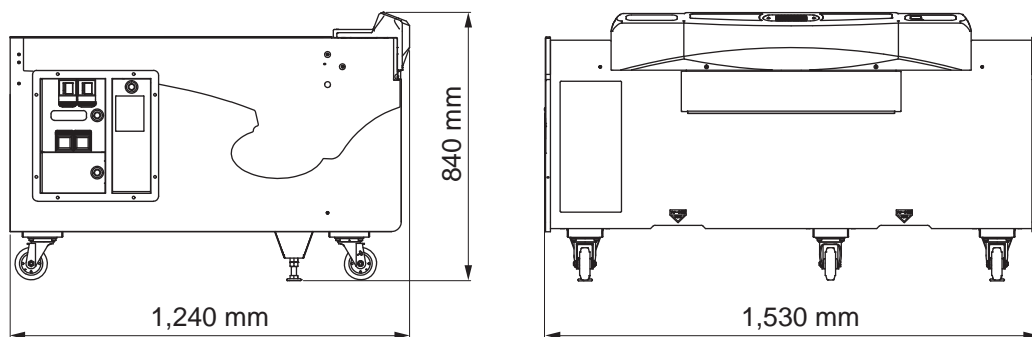

Test Mode

Troubleshooting

2. Specifications

Side tower assembly

Width (W) 960 x Depth (D) 1,030 x Height (H) 2,050 [mm]
 (When the signboard is removed)
 Width (W) 960 x Depth (D) 1,030 x Height (H) 1,700 [mm]

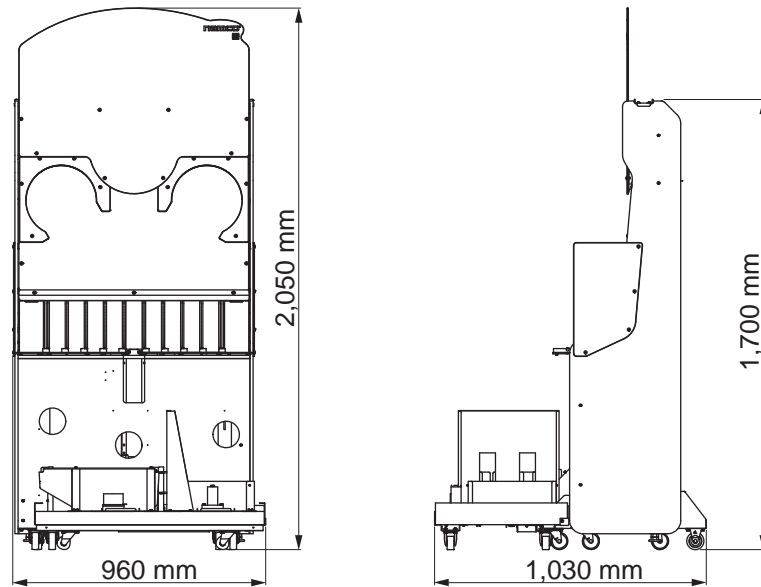

Hopper assembly

Width (W) 880 x Depth (D) 520 x Height (H) 530 [mm]

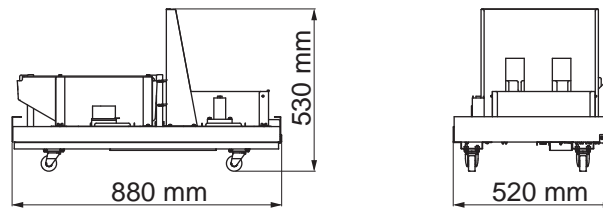

Side tower cabinet

Width (W) 920 x Depth (D) 620 x Height (H) 2,050 [mm]

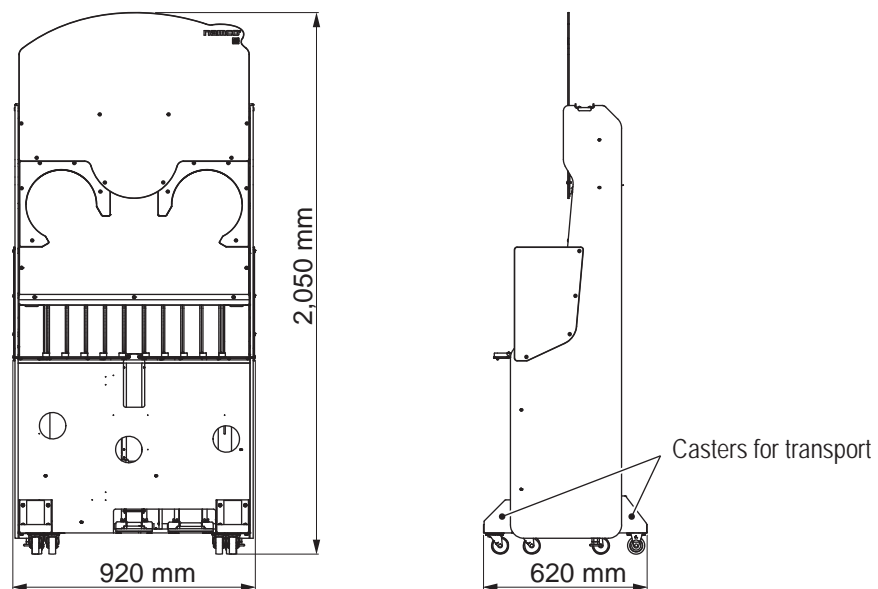

(6) Weight

1) When installed	Approx. 395 kg
2) When disassembled	
Table	Approx. 280 kg
Side tower assembly	Approx. 115 kg

3. Package Contents

The following items are included when this machine is shipped.

(1) Side tower cabinet	Width (W) 920 x Depth (D) 620 x Height (H) 1,710 [mm] Weight 85 kg
(2) Cabinet (L) assembly	Width (W) 1,540 x Depth (D) 1,240 x Height (H) 780 [mm] Weight 130 kg
(3) Cabinet (R) assembly	Width (W) 1,540 x Depth (D) 1,240 x Height (H) 780 [mm] Weight 115 kg
(4) Table top assembly	Width (W) 2,100 x Depth (D) 1,520 x Height (H) 160 [mm] Weight 100 kg
(5) Hopper assembly	Width (W) 950 x Depth (D) 570 x Height (H) 360 [mm] Weight 30 kg
(6) Center guard	Width (W) 1,650 x Depth (D) 700 x Height (H) 70 [mm] Weight 8 kg
(7) Side net	Width (W) 1,240 x Depth (D) 1,130 x Height (H) 160 [mm] Weight 20 kg
(8) Light Assembly	Width (W) 1,370 x Depth (D) 440 x Height (H) 320 [mm] Weight 16 kg



- Make sure that all the items below are contained in the product package.
- If any items are missing, contact your distributor.

- 1
- 2
- 3
- 4
- 5
- 6
- 7
- 8A
- 8B
- 9
- 10
- 11
- 12

Specifications / Package Contents

Test Mode



Troubleshooting

3. Package Contents

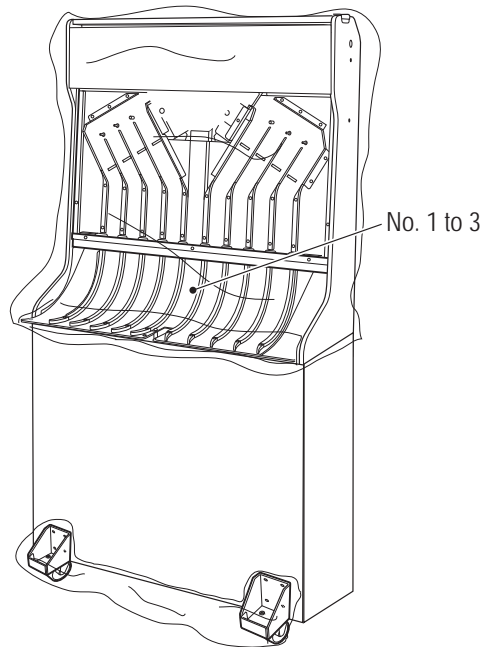
(1) Side tower cabinet



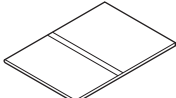



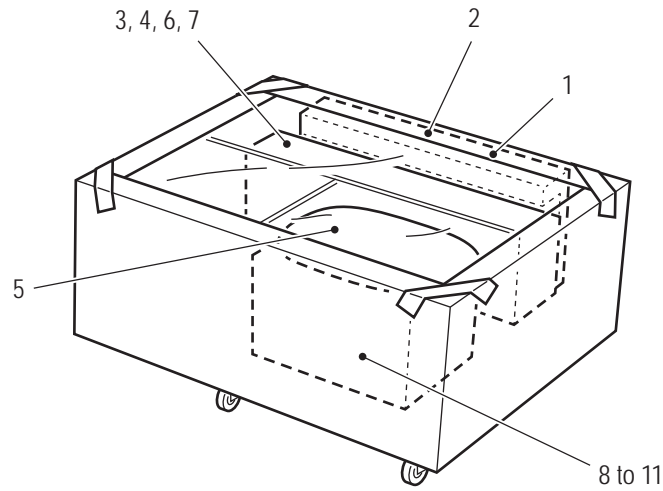

● Package contents

No.	Name	Specification	Qty.
1	Operation Manual (this manual)		1
2	Service key		2
3	Torx wrench	T25, for M5 	1

(2) Cabinet (L) assembly

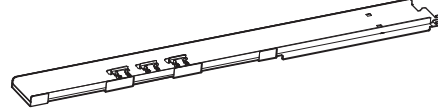
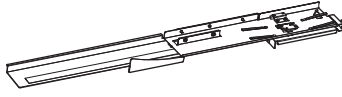
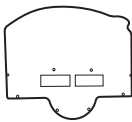
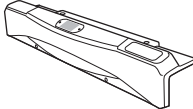
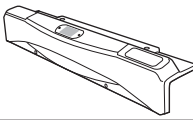

● Package contents

No.	Name	Specification	Qty.
1	Service key		2
2	Goal (R) assembly		1
3	Rail (L) assembly		1
4	Rail (R) assembly		1
5	Signboard		1
6	Goal cover (RED)		1
7	Goal cover (BLUE)		1
8	Corner cover	Four types: (Red • L), (Red • R), (Blue • L), (Blue • R) 	4 types
9	Mallet		4
10	Big puck		100
11	Mini puck	(Pink, orange, green: 100 each) 	300

- 1
- 2
- 3
- 4
- 5
- 6
- 7
- 8A
- 8B
- 9
- 10
- 11
- 12

Package Contents

Test Mode





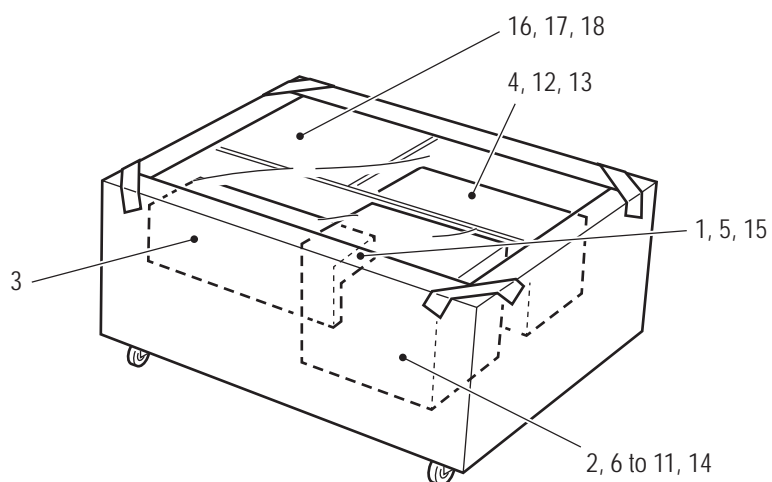

Troubleshooting

3. Package Contents



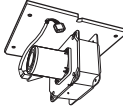

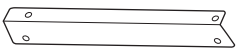

(3) Cabinet (R) assembly

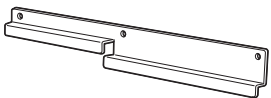
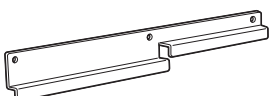
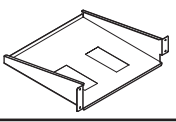

● Package contents

No.	Name	Specification	Qty.
1	Service key		2
2	Screws	See "● List of screws" on page 20.	1 set
3	Goal (L) assembly		1
4	Blower fan		1
5	Cash box key		2
6	Side wall		2
7	Side tower bracket (L)		1
8	Side tower bracket (R)		1
9	Center guard bracket (A)		1

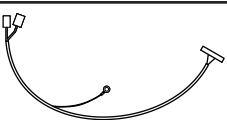
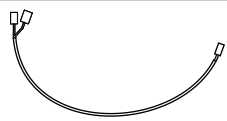
3. Package Contents

No.	Name	Specification	Qty.
10	Center guard bracket (B)		1
11	Triangle bracket		1
12	Blower bracket (L)		1
13	Blower bracket (R)		1
14	Hopper wall		1
15	Selector door key		2
16	CASHFLOW selector option cable		1
17	CASHFLOW counter option cable		1
18	Ticket dispenser option cable		2

- 1
- 2
- 3**
- 4
- 5
- 6
- 7
- 8A
- 8B
- 9
- 10
- 11
- 12

Package Contents

(4) Table top assembly

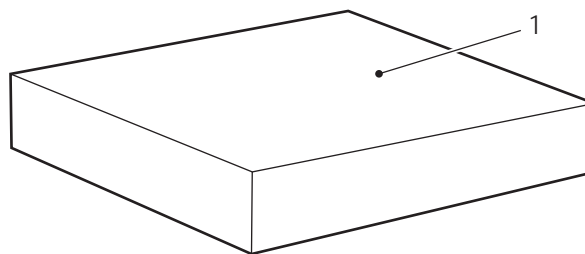

● Package contents

No.	Name	Specification	Qty.
1	Table top assembly		1

- Test Mode
- Troubleshooting

3. Package Contents

(5) Hopper assembly

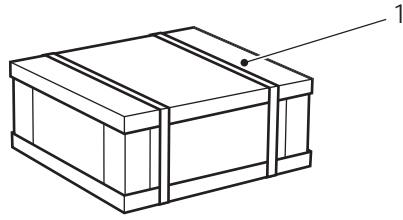

● Package contents

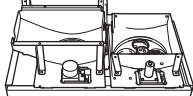
No.	Name	Specification	Qty.
1	Hopper assembly		1

(6) Center guard

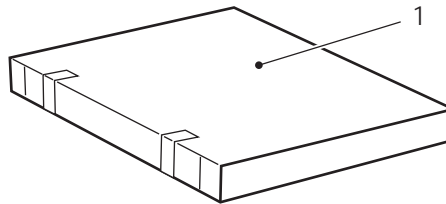

● Package contents

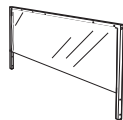
No.	Name	Specification	Qty.
1	Center guard unit		1



3. Package Contents

(7) Side net

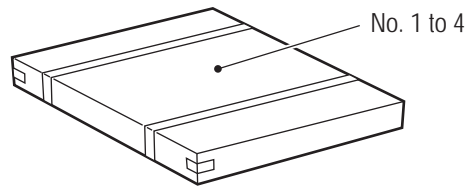

● Package contents

No.	Name	Specification	Qty.
1	Net L frame (L)		1
2	Net L frame (R)		1
3	Net S frame (L)		1
4	Net S frame (R)		1

(8) Light Assembly

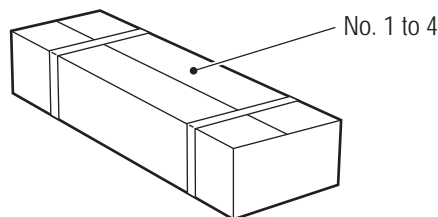

● Package contents

No.	Name	Specification	Qty.
1	Light arm L		1
2	Light arm R		1
3	Light frame unit		1
4	Connector cover		1











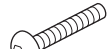
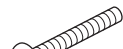

- 1
- 2
- 3
- 4
- 5
- 6
- 7
- 8A
- 8B
- 9
- 10
- 11
- 12

Package Contents













- Test Mode
- Troubleshooting

3. Package Contents

● List of screws (included with the cabinet (L) assembly)

No.	Name	Specification		Qty.
B1	Phillips hexagon socket head bolt (with flat and spring washers)	M8×35		10
B2	Button head bolt	M5×16		5
B3	Button head bolt	M5×35		4
B4	Button head bolt	M6×16		3
B5	Button head bolt	M6×25		12
B6	Button head bolt	M6×40		14
B7	Button head bolt	M6×50		18
B8	Flange socket bolt	M5×10		8
B9	Flange socket bolt	M5×16		6
B10	Flange socket bolt	M5×30		4
B11	Flange socket bolt	M5×35		2
B12	Flange socket bolt	M6×20		12
B13	Torx bolt	M5×8		4
B14	Torx bolt	M5×12		8

3. Package Contents

No.	Name	Specification	Qty.
B15	Torx bolt	M5×16 	12
B16	Hex nut with flange	M5 	3
B17	Torx bolt	M5×20 	4
B18	Countersunk cap bolt	M5×35 	2
B19	Square washer	M8 	10
B20	Spring washer	M6 	6
B21	Flat washer	M5 	13
B22	Flat washer	ø24 for M5 	4
B23	Flat washer	M6 	23
B24	Flat washer	ø16 for M6 	14
B25	Phillips pan head screw (with flat and spring washers)	M4×10 	5
B26	Flat washer	ø7×24 	4
B27	Flange socket bolt	M6×16 	2

- 1
- 2
- 3
- 4
- 5
- 6
- 7
- 8A
- 8B
- 9
- 10
- 11
- 12

Package Contents

- Test Mode
- Troubleshooting

4. Overall Structure (Part Names)

Overall

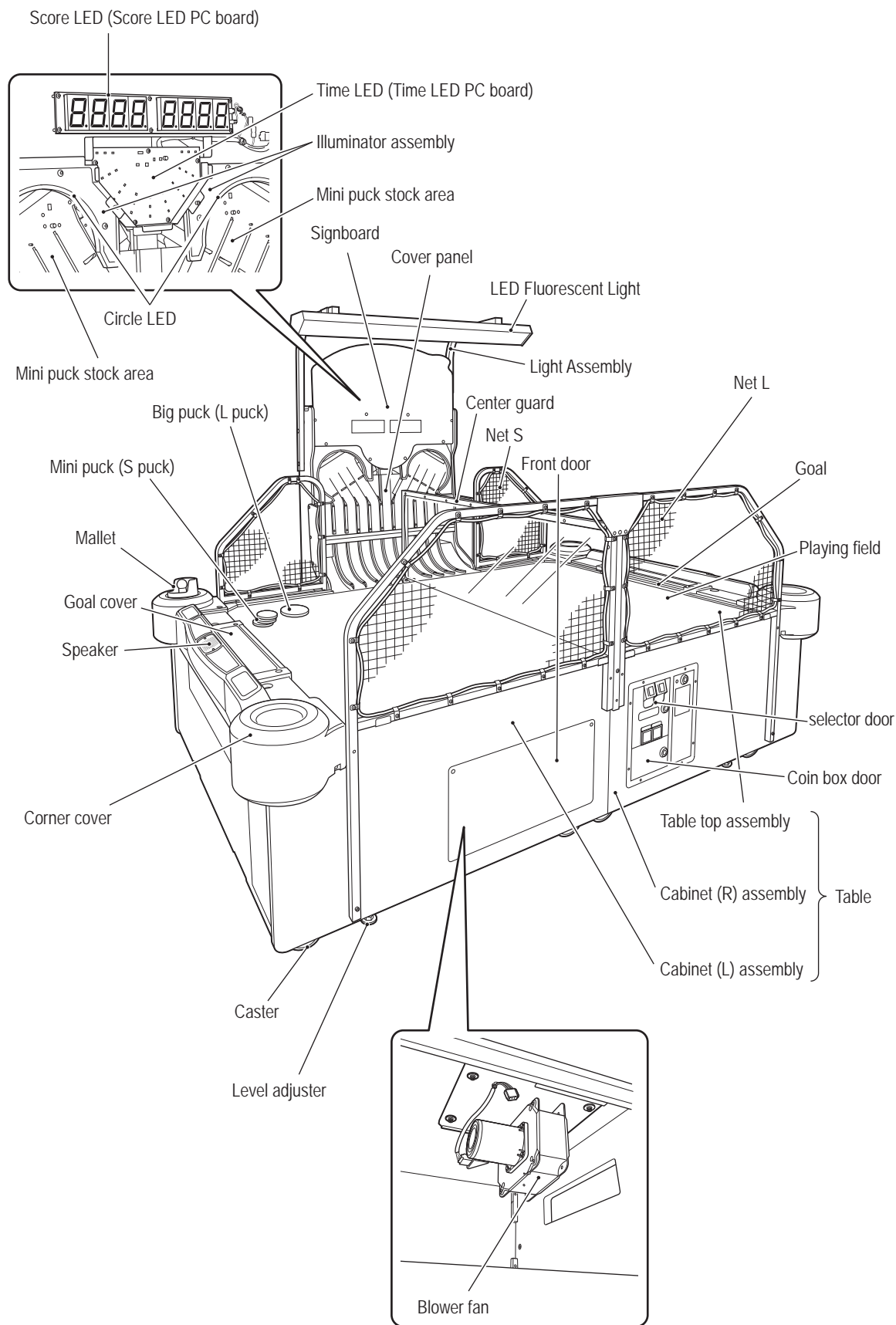



4. Overall Structure (Part Names)

Overall (back and interior)

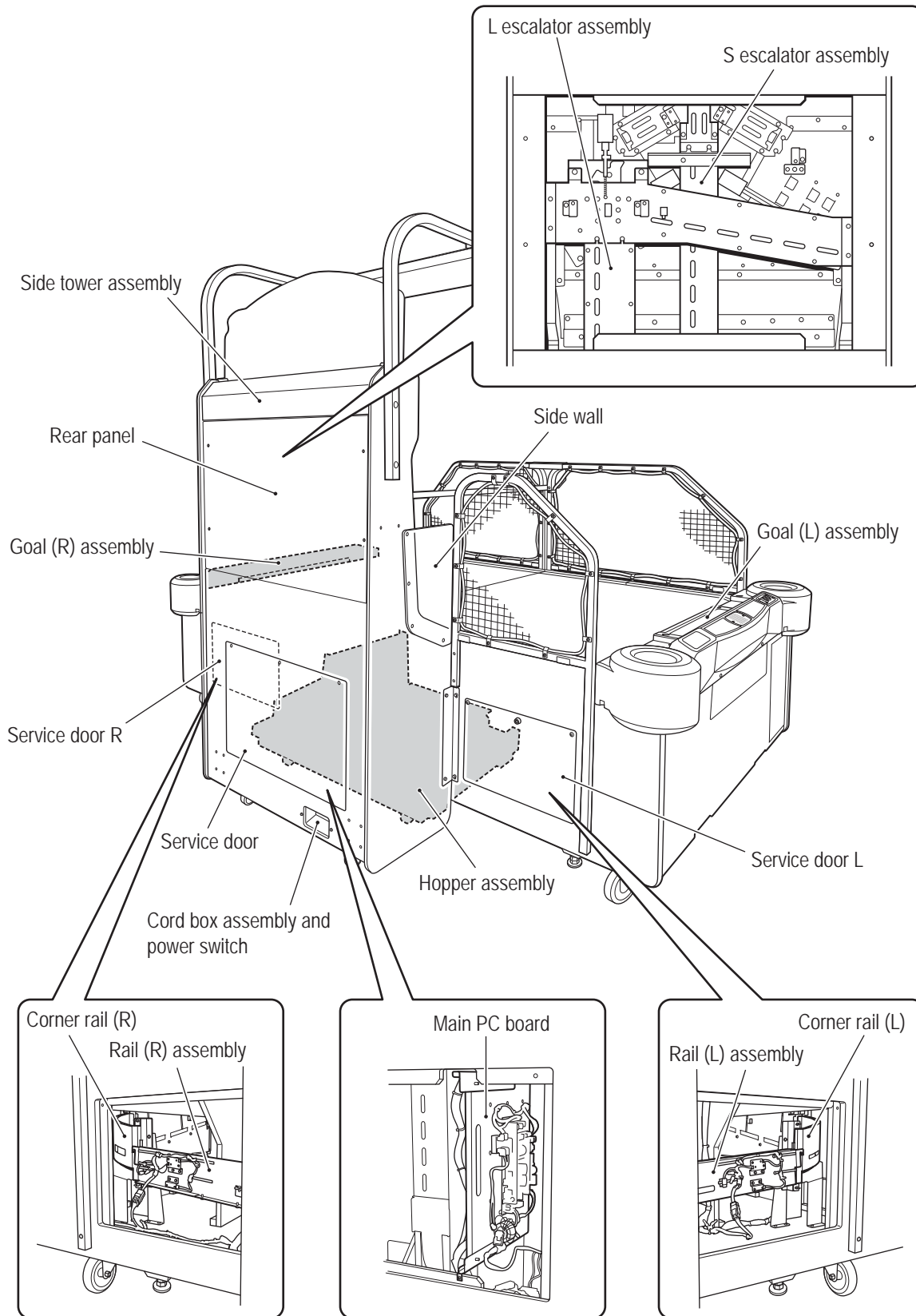

- 1
- 2
- 3
- 4
- 5
- 6
- 7
- 8A
- 8B
- 9
- 10
- 11
- 12

Overall Structure (Part Names)

Test Mode

Troubleshooting

5. Installation

WARNING

- Install the machine according to the instructions in this Operation Manual. Failure to follow these instructions may result in a fire, electric shock, injury or malfunction. (See “8A Installation and Assembly” on page 74.)
- Install the machine securely by using the level adjusters. Unstable machine installation may result in an accident or injury. (See “8A-2-2 Level Adjuster Adjustment” on page 90.)
- Fully insert the power cord plug into the outlet. Poor contact may generate heat and result in a fire or burns.
- Be sure to install the ground wire. Failure to install the ground wire may result in electric shock in the event of electrical leakage. (See “8A-3 Connecting the Power Cord and Ground” on page 106.)

5-1 Installation Conditions

5-1-1 Installation Locations to Avoid

WARNING

- The machine is designed for indoor use. Do not install the machine outdoors. Also, never install the machine in the following locations.
 - A location exposed to direct sunlight
 - A location exposed to rain or water leaks
 - A damp location
 - A dusty location
 - A location close to heaters
 - A hot location
 - An extremely cold location
 - A location exposed to condensation caused by temperature differences
 - A location that obstructs an emergency exit or fire extinguishing equipment
 - An unstable location or a location exposed to vibration

5-1-2 Play Zone for the Installed Machine

CAUTION

- Create a play zone around the machine so that players do not bump into bystanders or passersby.

NOTICE

- Leave a space of 100 cm or more between the machine and the wall or other machines so that parts can be removed when performing service work.
- A ceiling height of 2 m 10 cm or more is required.

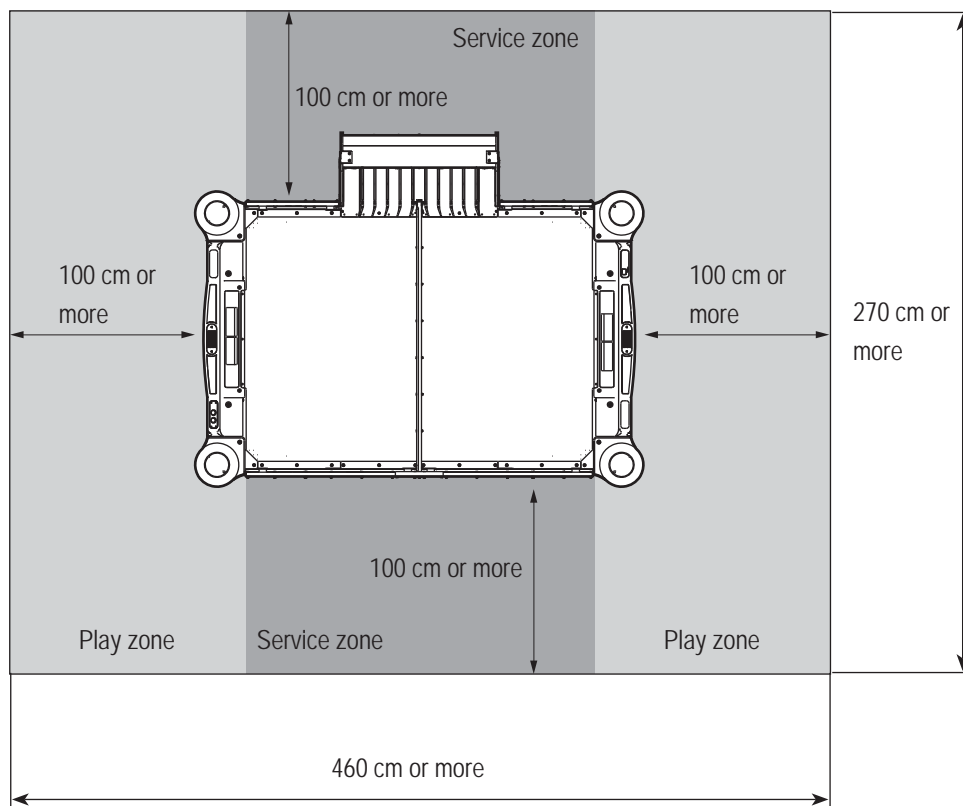

- 1
- 2
- 3
- 4
- 5
- 6
- 7
- 8A
- 8B
- 9
- 10
- 11
- 12

Installation Conditions

Test Mode

Troubleshooting

5-2 Required Dimensions for the Delivery Route (Such as Doors and Corridors)

Entranceways and the delivery route must be larger than the dimensions noted below.

● Table

Width (W) 2,570 x Depth (D) 1,690 x Height (H) 1,350 [mm]

Weight 280 kg

In addition, the table can be disassembled as follows. (Condition when shipped from the factory)

• Table top assembly

Width (W) 2,080 x Depth (D) 1,490 x Height (H) 120 [mm]

Weight 95 kg

• Cabinet (L) assembly (without net L and S)

Width (W) 1,530 x Depth (D) 1,240 x Height (H) 840 [mm]

Weight 85 kg

• Cabinet (R) assembly (without net L and S)

Width (W) 1,530 x Depth (D) 1,240 x Height (H) 840 [mm]

Weight 75 kg

● Side tower assembly

Width (W) 960 x Depth (D) 1,030 x Height (H) 2,050 [mm]

Weight 115 kg

The side tower assembly can be further disassembled as follows. (Condition when shipped from the factory)

• Side tower cabinet

Width (W) 920 x Depth (D) 620 x Height (H) 1,700 [mm]

Weight 90 kg

• Hopper assembly

Width (W) 880 x Depth (D) 520 x Height (H) 530 [mm]

Weight 25 kg

6. Moving and transporting

! WARNING

- Do not leave the machine on a slope. It may fall over or result in an accident.

6-1 Moving (On the Same Floor)

NOTICE

- Move the machine carefully to avoid damaging it.
- Do not exert force on the plastic parts when moving the machine.
- When moving the machine, be sure to raise the level adjusters to their highest level.
- Be sure to turn off the power switch before starting work.
- Handle the power cord carefully.

1

2

3

4

5

6

7

8A

8B

9

10

11

12

Required Dimensions for the Delivery Route (Such as Doors and Corridors) / Moving (On the Same Floor)

Test Mode

Troubleshooting

6-2 Transporting

6-2-1 Transporting Manually (Such as Carrying on Stairs)

WARNING

- Before transporting the machine manually, be sure to disassemble it into the table and side tower assembly, and disassemble the hopper assembly from the side tower assembly for easier carrying. Straining yourself by attempting to transport the fully assembled machine may result in an accident or injury.
- Disassemble the table in accordance with the delivery route. (See “5-2 Required Dimensions for the Delivery Route (Such as Doors and Corridors)” on page 26.)
- When transporting the machine by hand, be sure to use the following number of people. Straining yourself may result in an accident or injury.

- Table (280 kg): 12 people or more

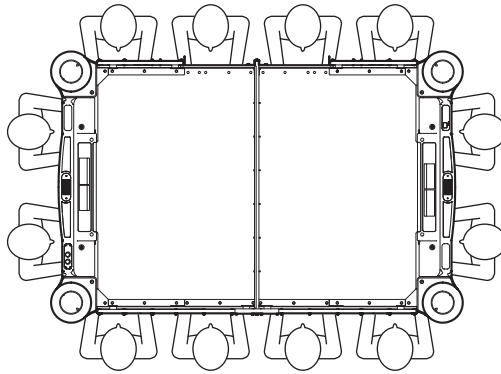

- Side tower cabinet (excluding the hopper assembly: 90 kg): 4 people or more

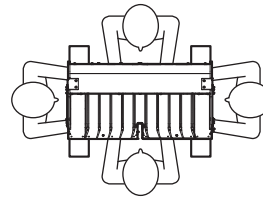

- Hopper assembly (25 kg): 2 people or more

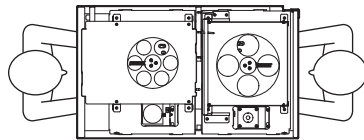



- 1
- 2
- 3
- 4
- 5
- 6
- 7
- 8A
- 8B
- 9
- 10
- 11
- 12

Transporting

! WARNING

● When transporting the machine by hand, be sure to use the following number of people. Straining yourself may result in an accident or injury.

[When the table is disassembled]

- Table top assembly (95 kg): 4 people or more
- Cabinet (L) assembly (85 kg): 4 people or more
- Cabinet (R) assembly (75 kg): 4 people or more

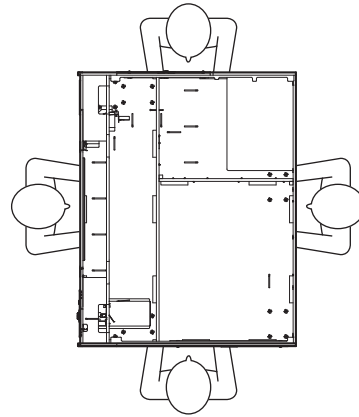
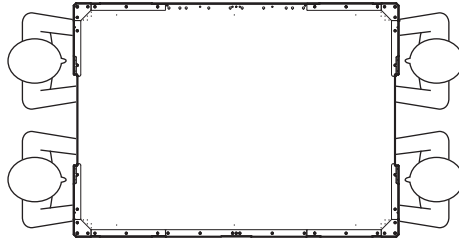

- Goal (L) assembly (17 kg): 2 people or more
- Goal (R) assembly (17 kg): 2 people or more

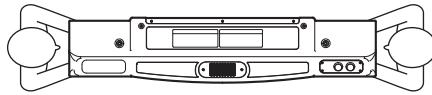

NOTICE

● Do not subject the machine to impact while lowering it.

Test Mode

Troubleshooting

6-2-2 Loading and Unloading to and from a Vehicle

WARNING

- When using a forklift to transport the machine, observe the following. Failure to observe the following instructions may result in an accident, such as the machine falling over.
 - Be sure to insert the fork into the specified positions.
 - Make sure that the machine is balanced properly during transportation.

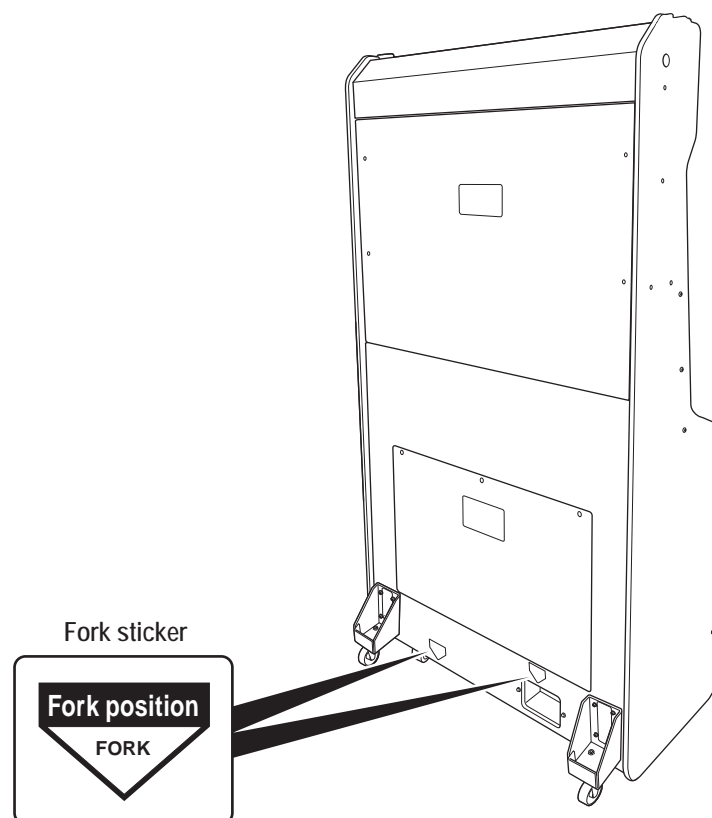
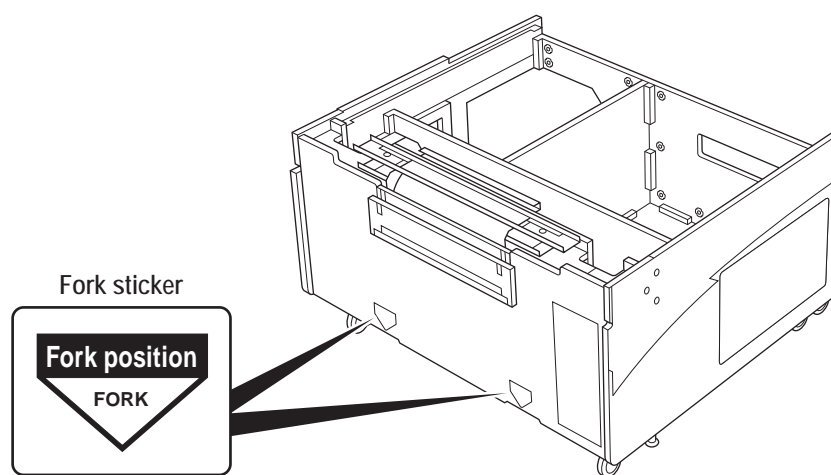

NOTICE

- Do not subject the machine to impact while lowering it.



6-2-3 Transporting on a Vehicle

! WARNING

● When transporting the machine on a vehicle, secure the machine firmly so that it does not move during vehicle transport. Failure to secure the machine may result in an accident.

NOTICE

- Do not subject the machine to impact while lowering it.
- Remove any pucks from inside the side tower cabinet when transporting the machine.
- When securing the machine with a rope, observe the following.
 - Be sure to secure the machine with the rope or belt in the position shown in the figure below.
 - Place blankets or other shock absorbing material between the machine and the rope or belt to protect the machine surfaces.
- Place Styrofoam or other shock absorbing material between the machine and the truck bed and any other equipment or items to protect the machine surfaces.
- When transporting the machine in rainy weather, use a vehicle with a cargo cover, a container truck, or similar vehicle to protect the machine from direct exposure to rain.

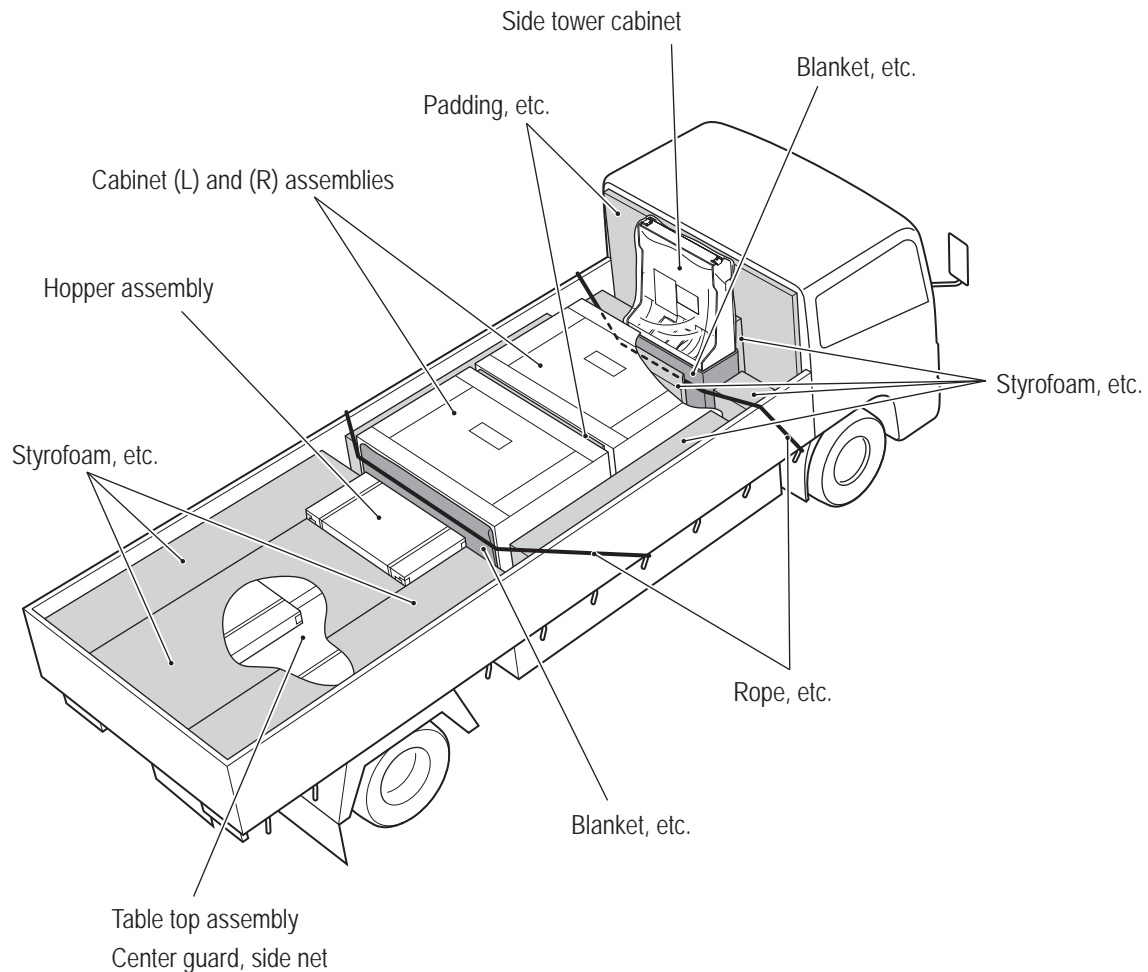

- 1
- 2
- 3
- 4
- 5
- 6
- 7
- 8A
- 8B
- 9
- 10
- 11
- 12

Transporting

Test Mode

Troubleshooting

7. Operation

WARNING

- Should an abnormality occur, turn off the power switch immediately to stop operations. Then, be sure to disconnect the power cord plug from the outlet. Operating the machine while the abnormality persists may result in a fire or accident.
- Dust accumulating on the power cord plug may result in a fire. Inspect the plug regularly and remove any dust.
- Fully insert the power cord plug into the outlet. Poor contact may generate heat and result in a fire or burns.
- Before operating the machine, be sure to check that installation has been performed according to the instructions and specified procedures (See “5 Installation” on page 24.) in this Operation Manual. Failure to install the machine correctly may result in a fire, electric shock, injury or malfunction.
- The warning labels attached to the machine contain important information for ensuring safety. Be sure to observe the following. (For the warning label locations, see “1-4 Machine Warning Labels” on page 3.)
 - To ensure that the warning labels attached to the machine are always clearly visible, install the machine in an appropriate location with ample illumination and keep the labels clean at all times. Make sure that the labels are not hidden by other machines or objects.
 - Do not remove or alter the warning labels.
 - If a warning label becomes excessively dirty or damaged, replace it with a new one.
To order warning labels, contact your distributor.
- To ensure safe use of the machine, be sure to perform the pre-operation inspection (See “7-4 Pre-operation Inspection” on page 35.) and service (See “8B Service” on page 109.) described in this Operation Manual. Omitting these inspections or service may result in an accident.

NOTICE

- Due to the nature of this product, the mallets and pucks may get stolen. If possible, install and operate the machine in a location where it can be observed by venue staff.
- Mallets and pucks may be left on the playing field after game play has finished. In these cases, return the mallets to the mallet holders, and place the pucks inside the goals.
- Caution players and bystanders not to place drinks or other items on the playing field. In the event that drinks are spilled onto the machine by accident, wipe away any liquid immediately.

7-1 People Who Should Avoid Playing

WARNING

- To ensure the safety of players, be careful not to let the following types of people play. Otherwise, this may result in an accident.
 - People who disregard the warning labels attached to the machine

7-2 Safety Precautions for Playing

WARNING

- If you discover anyone behaving as follows, be sure to caution them. Otherwise, this may result in an accident.
 - A person other than the player in the play zone
- Make sure that players do not perform the following actions, as this may cause pucks to fly out of the machine and strike people or otherwise result in injury or an accident.
 - Striking pucks with more power than is necessary
 - Striking pucks while off-balance, leaning in or an otherwise unstable body posture
 - Using items other than the supplied mallets and pucks

CAUTION

- Make sure that players do not perform the following actions, as this may result in injury or an accident.
 - Holding mallets by the circumference.
 - Placing hands not holding a mallet in the playing field.
 - Placing hands inside the goal holes.
- Accessories such as necklaces and bracelets, neckties, wristwatches, small items in breast pockets and other loose items may fall and enter the goals as a result of vigorous movements during game play. Instruct players to remove these items before playing in order to prevent damage or an accident. Otherwise, this may result in an accident.

1

2

3

4

5

6

7

8A

8B

9

10

11

12

People Who Should Avoid Playing / Safety Precautions for Playing

Test Mode

Troubleshooting

7-3 Important Parts for Ensuring Player and Bystander Safety

WARNING

- This machine includes important parts used to ensure the safety of players and bystanders. Operating the machine while these “important parts for ensuring player and bystander safety” are broken, damaged or deteriorated, or with defective installation may result in an injury to the players or bystanders. If you discover an abnormality, replace the affected part immediately. To order parts, contact your distributor.

Side wall
Part No.: 731-448

This part is used to keep pucks from flying out of the machine during game play.

Net S
Part No.: 731-338

This part is used to keep pucks from flying out of the machine during game play.

Center guard
Part No.: 731-332

This part is used to keep pucks from flying towards the opponent's side during game play.

Net L
Part No.: 731-337

This part is used to keep pucks from flying out of the machine during game play.

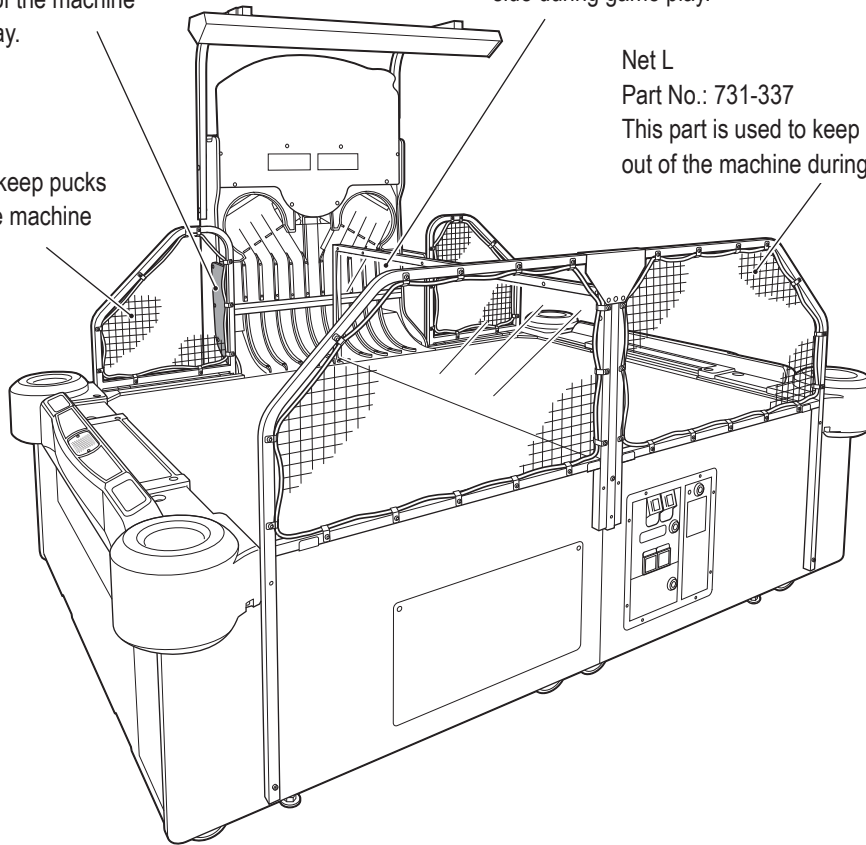

7-4 Pre-operation Inspection

Check the items below before starting machine operations. If there is an abnormality, resolve it by referring to “8B-3 Troubleshooting” on page 130.

7-4-1 Safety Inspection Items (Before Power On)

WARNING

- Before operating the machine, check the following locations. This is required to prevent accidents or injury.

- (1) Are all warning labels in place? (See “1-4 Machine Warning Labels” on page 3.)
- (2) Are all warning labels legible? (See “1-4 Machine Warning Labels” on page 3.)
- (3) Are all level adjusters adjusted properly? (See “8A-2-2 Level Adjuster Adjustment” on page 90.)
- (4) Is the specified play zone provided? (See “5-1-2 Play Zone for the Installed Machine” on page 25.)
- (5) Is the power cord laid out safely so that it will not cause players or other customers to trip over it?
- (6) Is the power cord securely connected to the outlet and the power supply input of the machine? (See “8A-3 Connecting the Power Cord and Ground” on page 106.)
- (7) Is the power cord plug free from dust?
- (8) Are the mallets damaged?
- (9) Are the mallet grips loose?
- (10) Are the net S, net L, center guard or side guards damaged? (See “7-3 Important Parts for Ensuring Player and Bystander Safety” on page 34.)
- (11) Are the goal covers or corner covers damaged?
- (12) Are the guide L or guide R damaged?

Inspect the following items after turning on the power switch. If you discover an abnormality, turn off the power switch immediately to stop operations. Then, disconnect the power cord plug from the outlet and contact your distributor.

- (13) Is any part of the power cord or plug abnormally hot?
- (14) Does touching the machine give a tingling electric shock?
- (15) Is there a burning smell, abnormal noise or vibration?
- (16) Is there any other abnormality or malfunction?

1

2

3

4

5

6

7

8A

8B

9

10

11

12

Important Parts for Ensuring Player and Bystander Safety / Pre-operation Inspection

Test Mode

Troubleshooting

7-4-2 Function Inspection Items (After Power On)

- (1) Check the lights. (Do the score LED, time LED and circle LED light up?)
(See "7-8-2 Score LED, Time LED and Circle LED Test" on page 42.)
- (2) Check the switch inputs.
(See "7-8-3 Switch Input Test" on page 43.)
- (3) Check the blower fan.
(See "7-8-4 Blower Fan ON/OFF Test and Sensor Check" on page 45.)
- (4) Check each solenoid.
(See "7-8-5 Solenoid ON/OFF Test and Sensor Check" on page 46.)
- (5) Check the L hopper motor operation.
(See "7-8-6 L Hopper Motor ON/OFF Test and Sensor Check" on page 47.)
- (6) Check the S hopper motor operation.
(See "7-8-7 S Hopper Motor ON/OFF Test and Sensor Check" on page 48.)
- (7) Check the audio. (Is sound produced by each speaker?)
(See "7-8-8 Sound Test" on page 49.)
- (8) Check the mini pucks. (Are there ten mini pucks in each of the mini puck stock areas on the right and left?)
(See "7-8-7 S Hopper Motor ON/OFF Test and Sensor Check" on page 48.)

7-5 Opening and Closing Doors

7-5-1 Opening and Closing the Selector Door

- 1 Use the supplied selector door key to open the selector door.

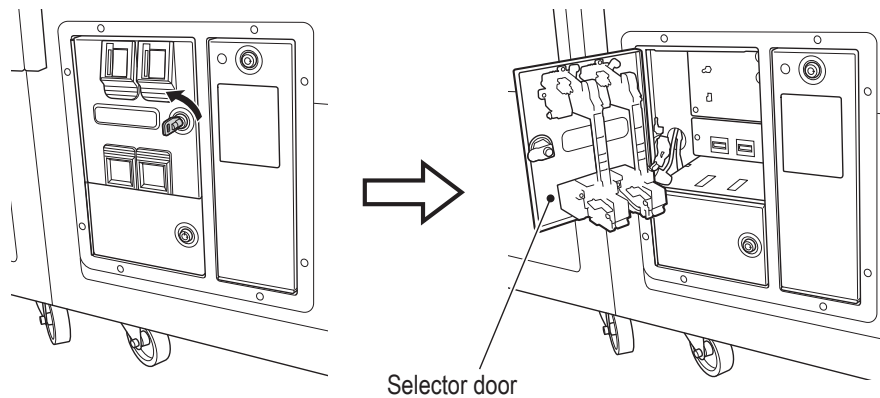

- 2 To close the door, perform the procedure in reverse.

7-5-2 Opening and Closing the Coin Box Door

- 1 Use the supplied cash box key to open the coin box door.

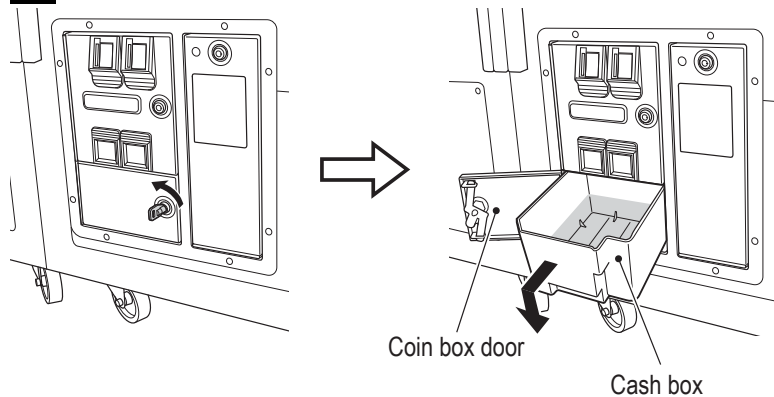

- 2 To close the door, perform the procedure in reverse.

- 1
- 2
- 3
- 4
- 5
- 6
- 7
- 8A
- 8B
- 9
- 10
- 11
- 12

Opening and Closing Doors

Test Mode

Troubleshooting

7-5-3 Opening and Closing the Goal (L) and (R) Assemblies

The description below explains how to open and close the (L) side. Follow the same procedure to open and close the (R) side.

- 1** Use the supplied service key to unlock the lock (①) on the left side of the goal (L) assembly, and then remove the service key from the lock.
- 2** Insert the removed service key into the lock (②) on the right side of the goal (L) assembly, unlock the lock, and then open the goal (L) assembly.

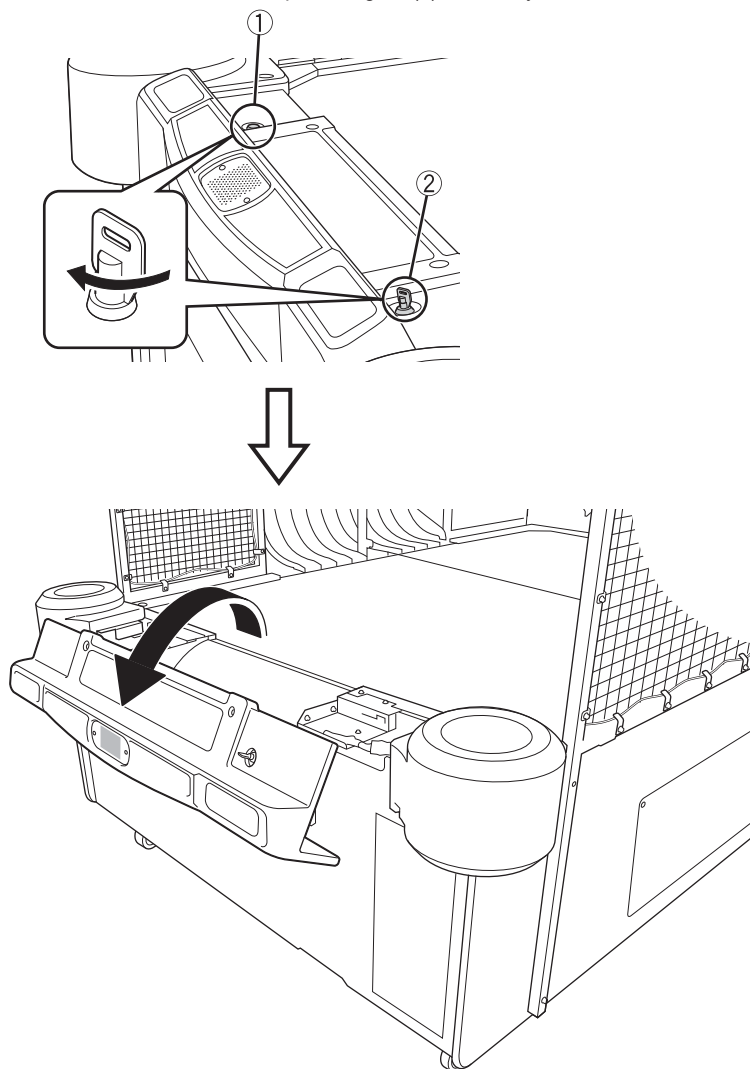

- 3** To close the door, perform the procedure in reverse.

7-6 Explanation of the Power Switch and Adjustment Switches

7-6-1 Turning the Power Switch On

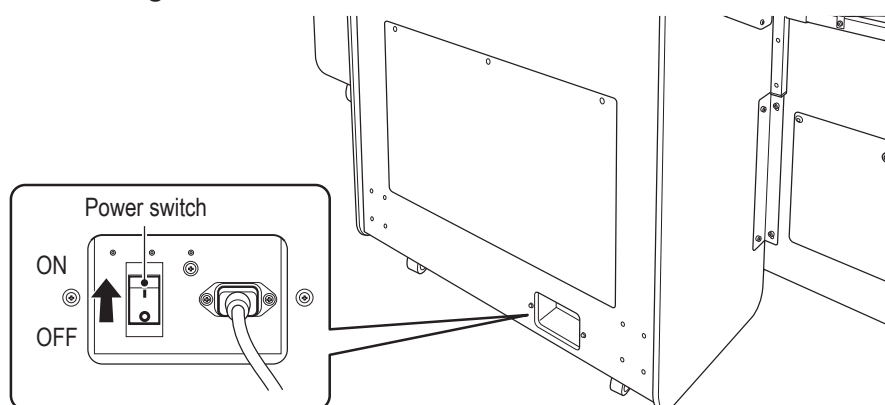

- After completing the installation work, turn on the power switch.
- When turning the power switch on and off, wait 30 seconds or more between operations. Do not turn the power switch on and off needlessly. It may corrupt the contents of the backup memory.

7-6-2 Adjustment Switches

The adjustment switches are located inside the selector door.

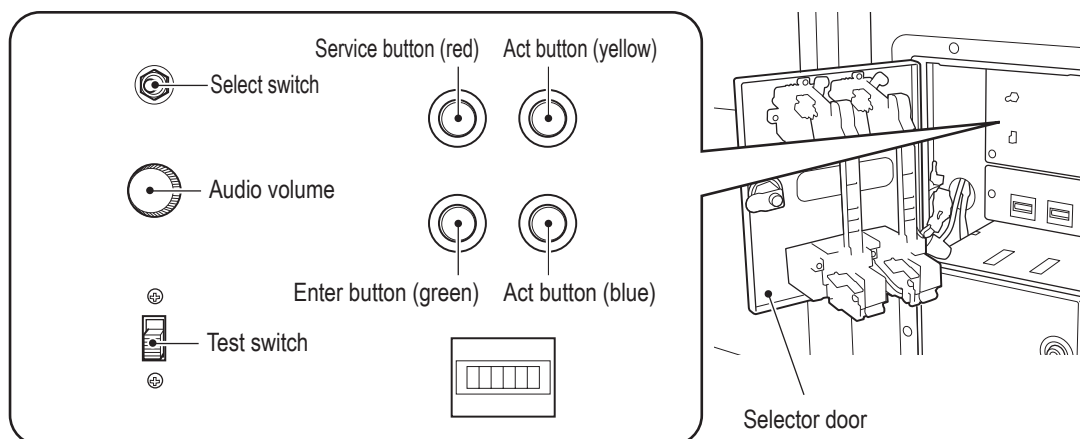

Select switch

In Test mode, flip this switch up or down to select an item or setting (numerical value).

Audio volume

This adjusts the speaker volume.
Turn counter-clockwise to decrease the volume.
Turn clockwise to increase the volume.

Test switch

Set this switch to ON to enter Test mode. This is used to test each part of the machine, such as the switch input test, in the Test mode. (See "7-8 Test Mode" on page 41.)

Service button (red)

Press this button to increase the credit count without operating the coin counter.

Enter button (green)

After selecting an item or setting (numerical value) with the Select switch, press this button to enter or execute the selection.

1

2

3

4

5

6

7

8A

8B

9

10

11

12

Explanation of the Power Switch and Adjustment Switches

Test Mode

Troubleshooting

7-7 Playing the Game

This machine is an air hockey game where players use mallets to hit pucks supplied automatically during the set time into the opponent's goal to score points.

- (1) The start sound is output, then a big puck is supplied to the playing field. At the same time, the time LED blinks.
- (2) Players use the mallets to hit the big puck towards the opponent's goal.
- (3) When the big puck enters a goal, 100 points are added to the score LED of the scoring player, and the goal sound (ascending musical scale) is output three times from the speaker on the side where the goal was scored.
- (4) A big puck is supplied to the playing field on the side where the goal was scored.
- (5) 20 mini pucks are supplied to the game all at once at random times during game play and toward the end of game play.
- (6) When a mini puck enters a goal, 30 points are added to the score LED of the scoring player and the goal sound (ascending musical scale) is output one time.
- (7) The countdown sound is output starting from 10 seconds before the game ends. When the end whistle is output, the game ends and subsequent goals are not added to the score.

*The number of mini puck supply times varies according to "7-9-4 Big Bang Mode play time", "7-9-6 Mini puck supply frequency more/less setting for Big Bang Mode" and the goal status during game play.

7-7-1 Starting the Game and Game End

- (1) Insert a number of coins equal to the set game cost into the coin slot.
- (2) When the set time is exceeded, the game ends.
The set time may be extended slightly depending on the number of mini puck supply times.

7-8 Test Mode

The machine displays the test contents on the signboard that displays the score and timer.

7-8-1 Test Item Selection Mode

- 1** Use the supplied service key to open the selector door and set the Test switch to ON (slide the switch upward) to enter the Test Item Selection Mode. (See "7-6-2 Adjustment Switches" on page 39.)
- 2** Flip the Select switch up and down to select the item.
- 3** Perform the test for each item.
- 4** After finishing all the tests, set the Test switch to OFF.



- Before setting the Test switch to OFF, make sure that there are ten mini pucks in each of the mini puck stock areas on the right and left.

Item order	Item name (Display in Test Item Selection Mode)	Item	Reference page
1		Score LED, Time LED and Circle LED Test	Page 42
2		Switch Input Test	Page 43
3		Blower Fan ON/OFF Test and Sensor Check	Page 45
4		Solenoid ON/OFF Test and Sensor Check	Page 46
5		L Hopper Motor ON/OFF Test and Sensor Check	Page 47
6		S Hopper Motor ON/OFF Test and Sensor Check	Page 48
7		Sound Test	Page 49
8		Ticket Dispenser Test * This is displayed only when the ticket dispenser use setting is "on". (See "7-8-9 Ticket Dispenser Test" on page 50.)	Page 50

1

2

3

4

5

6

7

8A

8B

9

10

11

12

Playing the Game / Test Mode

Test Mode

Troubleshooting

7-8-2 Score LED, Time LED and Circle LED Test

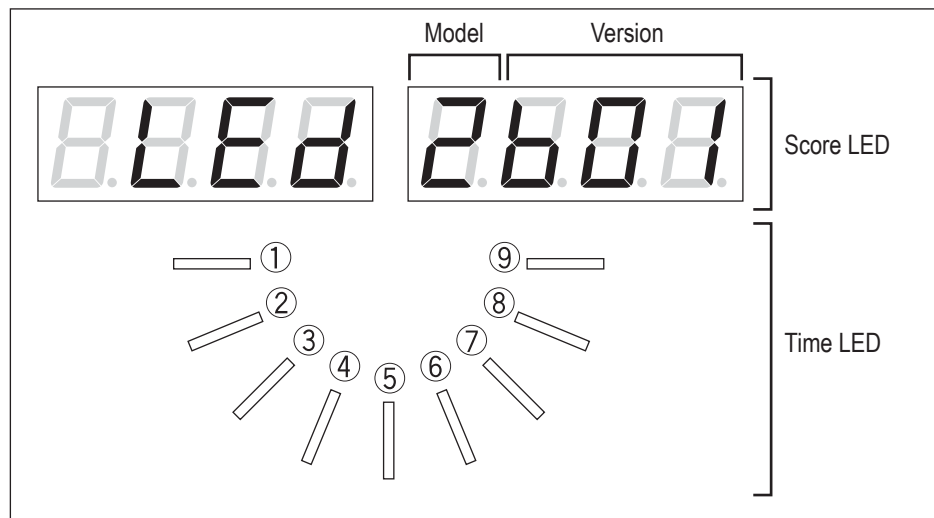

Test item selection display (Score LED, time LED and circle LED test)

- 1** In this Test Item Selection Mode, “LEd” is displayed in the left side score LED. The “model (1-digit number)” and “version (one alphabet character + 2-digit number)” are displayed in the right side score LED.

The model is indicated by a number, and has the following meaning.

Model No.	2
Model contents	Foreign

- 2** Press the Enter button (green) to start the test as follows.
- (1) Numbers are displayed in the score LED, switching repeatedly in order of 0, 1, 2, 3, 4, 5, 6, 7, 8 and 9.
 - (2) The time LED switches repeatedly in the order of all off, ⑨ only lighted, ⑨ and ⑧ only lighted, ..., all lighted.
 - (3) The circle LED (illuminator assembly) switches repeatedly in the order of lighted red, green, blue, light blue, purple, yellow, white, and off.

- 3** Press the Enter button (green) again to return to the Test Item Selection Mode.

7-8-3 Switch Input Test

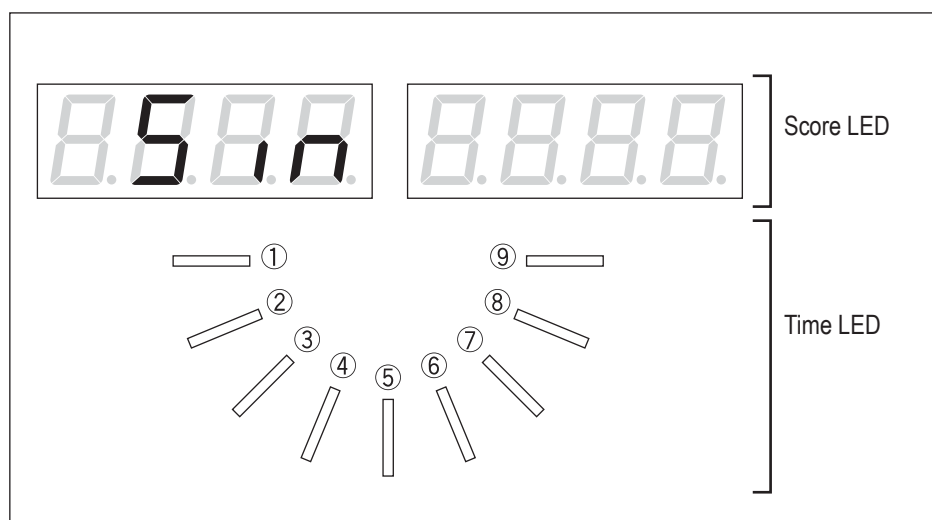

Test item selection display (Switch input test)

- 1** In this Test Item Selection Mode, "Sin" is displayed in the left side score LED.

- 1
- 2
- 3
- 4
- 5
- 6
- 7
- 8A
- 8B
- 9
- 10
- 11
- 12

Test Mode

Test Mode

Troubleshooting

2 Press the Enter button (green). The following test display appears.

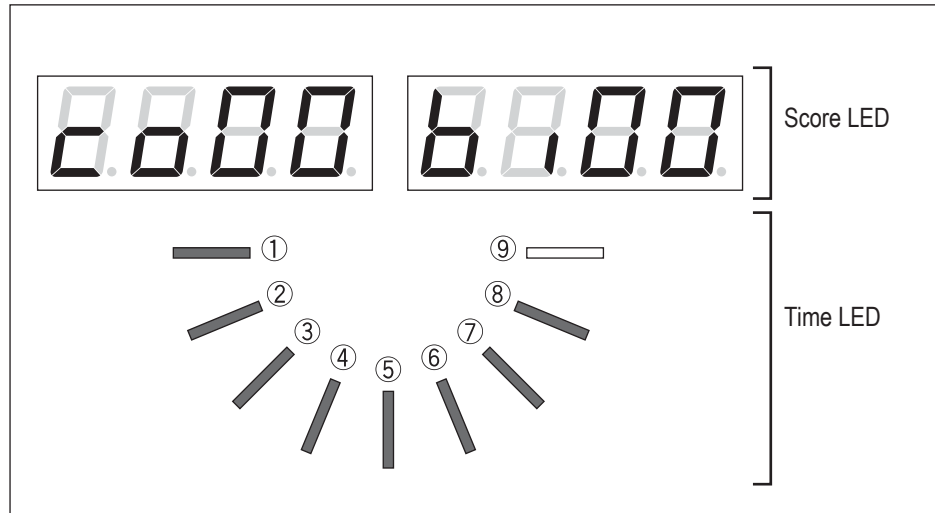

Switch input test display

- The coin switch counter value (two digits) is displayed in the left side score LED. The right side displays the bill counter input count (two digits).
 - (1) The value counts up each time there is switch input.
 - (2) The value returns to 00 after 99.
- The time LED displays the switch input states as follows.
(ON: Lighted, OFF: Off)

LED No.	Switch name
①	Service button (red)
②	Enter button (green)
③	Selector switch UP
④	Selector switch DOWN
⑤	Act button (yellow)
⑥	Act button (blue)
⑦	COIN
⑧	Bill counter input signal
⑨	Not used

3 Press both the Service button (red) and the Enter button (green) at the same time to return to the Test Item Selection Mode.

7-8-4 Blower Fan ON/OFF Test and Sensor Check

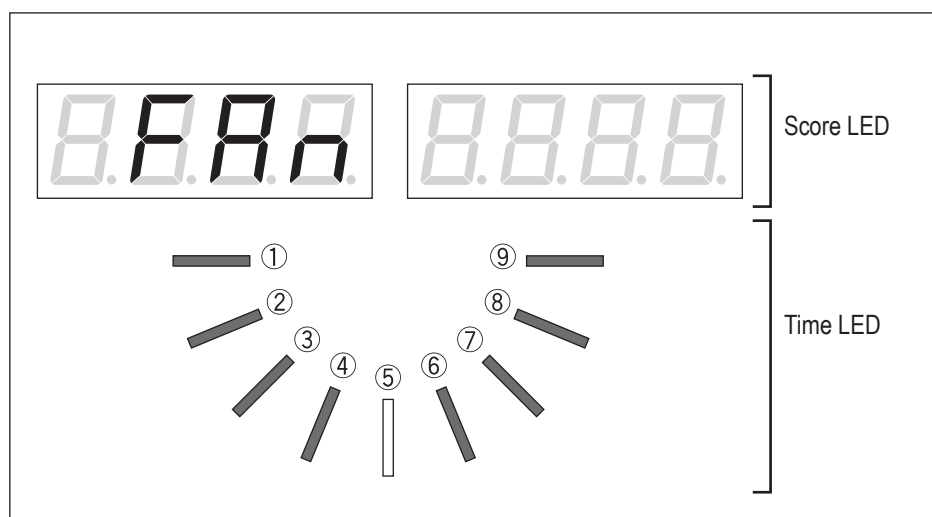

Test item selection display (Blower fan ON/OFF test)

- 1** In this Test Item Selection Mode, "FAn" is displayed in the left side score LED.
- 2** The time LED displays the sensor states as follows.
(ON: Lighted, OFF: Off)

LED No.	Sensor name	Reference page
①	Rail (L) sensor (lower)	Page 144
②	Rail (L) sensor (middle)	Page 142
③	Rail (L) sensor (upper)	
④	Goal (L) sensor	Page 141
⑤		
⑥	Goal (R) sensor	Page 141
⑦	Rail (R) sensor (upper)	Page 142
⑧	Rail (R) sensor (middle)	
⑨	Rail (R) sensor (lower)	Page 144

- 3** Press the act button (yellow) to control the blower fan ON and OFF. ON: "on" is displayed in the right side score LED, OFF: Nothing is displayed in the right side score LED.

1

2

3

4

5

6

7

8A

8B

9

10

11

12

Test Mode

Test Mode

Troubleshooting

7-8-5 Solenoid ON/OFF Test and Sensor Check

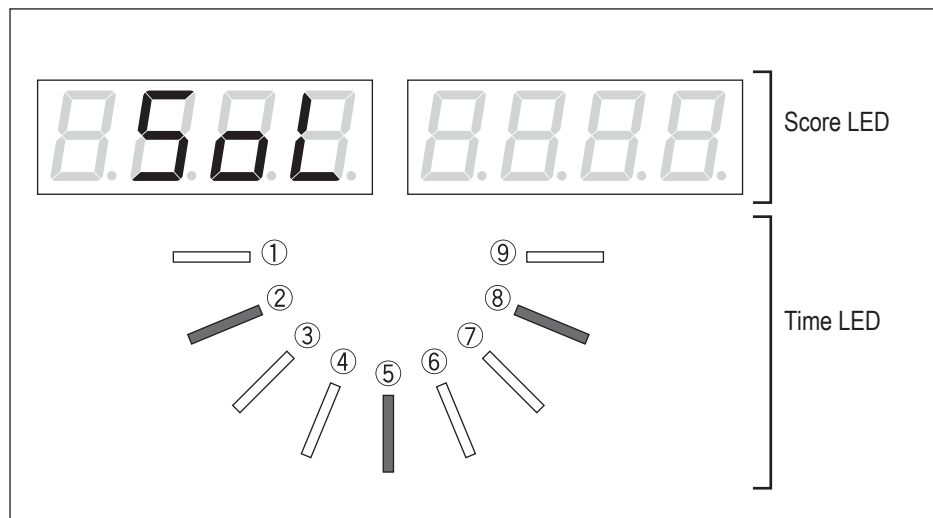

Test item selection display (Solenoid ON/OFF test)

- 1** In this Test Item Selection Mode, "Sol" is displayed in the left side score LED.
- 2** The time LED displays the sensor states as follows.
(ON: Lighted, OFF: Off)

LED No.	Sensor name	Reference page
①		
②	Stopper sensor (L)	Page 163
③		
④		
⑤	L divider sensor	Page 166
⑥		
⑦		
⑧	Stopper sensor (R)	Page 163
⑨		

- 3** Press the act button (yellow) to control the L divider solenoid ON and OFF, and press the act button (blue) to control the S stopper solenoids (L) and (R) ON and OFF. The L divider solenoid ON: "Lon" is displayed in the right side score LED, The Stopper solenoid ON: "Son", Both ON: "LSON", Both OFF: Nothing

* Each solenoid automatically turns off 3 seconds after it is turned on.



- Before setting the Test switch to OFF, make sure that there are ten mini pucks in each of the mini puck stock areas on the right and left.

7-8-6 L Hopper Motor ON/OFF Test and Sensor Check

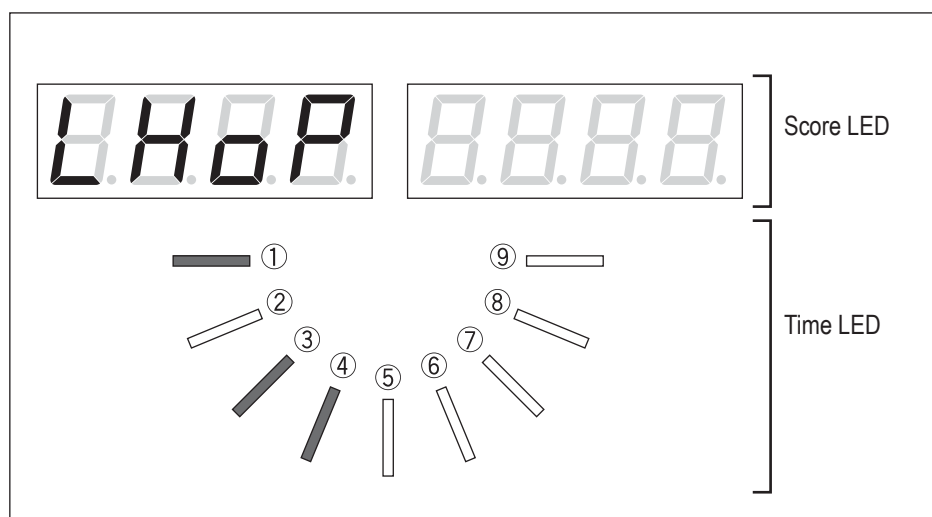

Test item selection display (L hopper motor ON/OFF test)

- 1** In this Test Item Selection Mode, “LHoP” is displayed in the left side score LED.
- 2** The time LED displays the sensor states as follows.
(ON: Lighted, OFF: Off)

LED No.	Sensor name	Reference page
①	L hopper motor sensor	Page 154
②		
③	L divider (L) outlet sensor	Page 167
④	L divider (R) outlet sensor	
⑤		
⑥		
⑦		
⑧		
⑨		

- 3** Press the act button (yellow) to release a big puck from the L side, and press the act button (blue) to release a big puck from the R side. “Lon” is displayed in the right side score LED while releasing the big puck from the L side, “ron” from the R side, and nothing after the big puck is released.



- Even when the machine state is normal, the “L Hopper Idling Error (Err14)” may occur when puck supply operation is performed immediately after installation is complete. In this case, perform the test again.

1

2

3

4

5

6

7

8A

8B

9

10

11

12

Test Mode

Test Mode

Troubleshooting

7-8-7 S Hopper Motor ON/OFF Test and Sensor Check

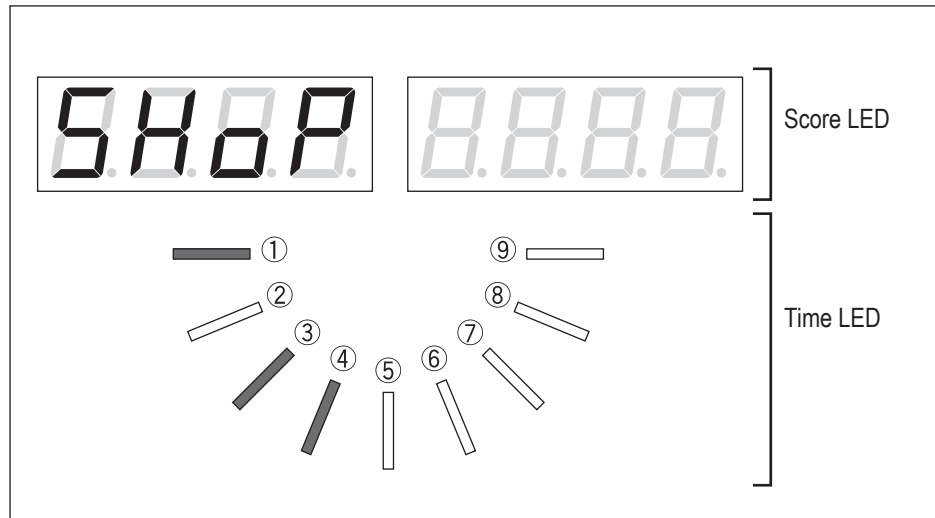

Test item selection display (S hopper motor ON/OFF test)

- 1** In this Test Item Selection Mode, “SHoP” is displayed in the left side score LED.
- 2** The time LED displays the sensor states as follows.
(ON: Lighted, OFF: Off)

LED No.	Sensor name	Reference page
①	S hopper motor sensor	Page 158
②		
③	S divider (L) outlet sensor	Page 164
④	S divider (R) outlet sensor	
⑤		
⑥		
⑦		
⑧		
⑨		

- 3** Press the act button (yellow) to release and add mini pucks. “on” is displayed in the right side score LED while releasing and adding pucks, and nothing after the mini pucks have been added.

NOTICE

- Even when the machine state is normal, the “S Hopper Idling Error (Err13)” may occur when puck supply operation is performed immediately after installation is complete. In this case, perform the test again.
- Before setting the Test switch to OFF, make sure that there are ten mini pucks in each of the mini puck stock areas on the right and left.

7-8-8 Sound Test

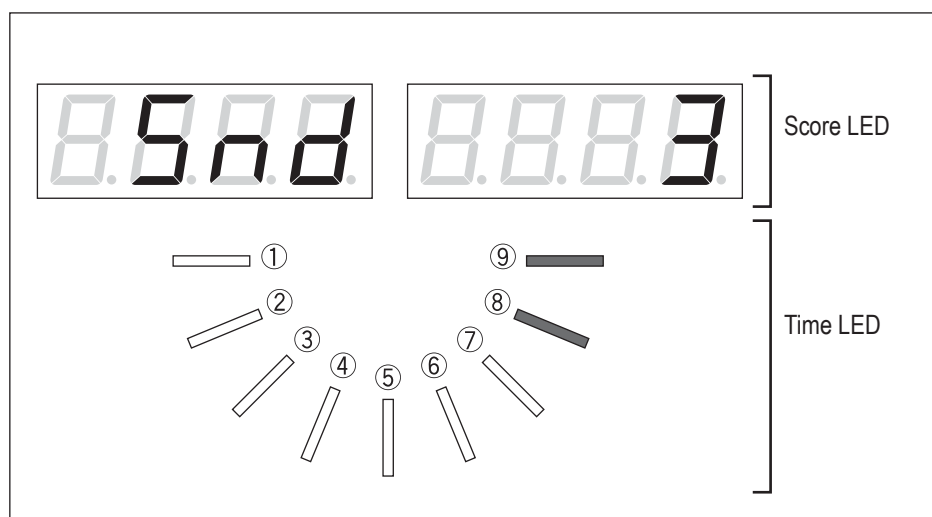

Test item selection display (Sound test)

- 1** In this Test Item Selection Mode, "Snd" is displayed in the left side score LED.
- 2** Press the act button (yellow) to play the speaker test sound from only the L side speaker, only the R side speaker, and both the L and R side speakers, in that order. "on" is displayed in the right side score LED during the speaker test, and nothing after speaker test.
- 3** The sound volume (0 to 15) is displayed in the right side score LED.
* The sound volume (0 to 15) is displayed as a binary value in the time LED.

1

2

3

4

5

6

7

8A

8B

9

10

11

12

Test Mode

Test Mode

Troubleshooting

7-8-9 Ticket Dispenser Test

* This item is displayed only when the ticket dispenser use setting is "on".
(See "7-9-11 Ticket Dispenser Use Setting" on page 63.)

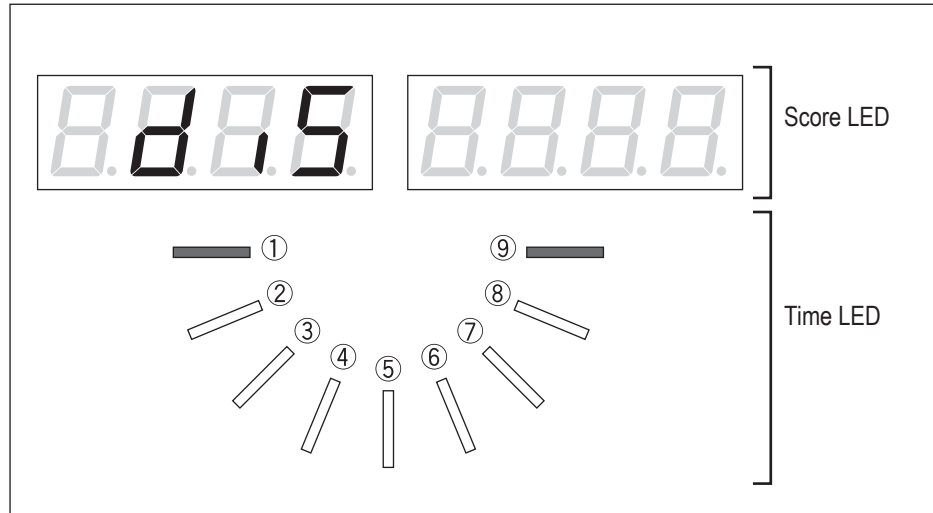

Test item selection display (Ticket dispenser test)

- 1** In this Test Item Selection Mode, "diS" is displayed in the left side score LED.
- 2** The time LED displays the status of the following sensors.
(ON: lighted, OFF: off)

LED No.	Sensor name	Reference page
①	Ticket dispenser (L) ticket payout sensor	—
②		
③		
④		
⑤		
⑥		
⑦		
⑧		
⑨	Ticket dispenser (R) ticket payout sensor	—

- 3** Press the act button (yellow) to pay out one ticket from the L side, and the act button (blue) to pay out one ticket from the R side. "Lon" is displayed in the right side score LED while the ticket is being out from the L side, and nothing after the mini pucks have been added, "ron" from R side, "Lron" from both L side and R side, and nothing when payout is finished.

7-9 Setting Mode

The machine displays the setting contents on the signboard that displays the score and timer.

7-9-1 Setting Item Selection Mode

- 1** Use the supplied service key to open the selector door, and set the Test switch to ON (slide the switch upward) while pressing the Enter button (green) to enter the Setting Mode. (See "7-6-2 Adjustment Switches" on page 39.)
- 2** Flip the Select switch up and down to select the item.
- 3** Press the Enter button (green) to enter the selected item.
- 4** Flip the Select switch up and down to select the setting value.
- 5** Press the Enter button (green) to return to the Setting Item Selection Mode.
- 6** After finishing all the settings, set the Test switch to OFF. Changed setting values are saved when the Test switch is set to OFF.
*If the power switch is turned off before the Test switch is set to OFF, the setting values will not be reflected.

1

2

3

4

5

6

7

8A

8B

9

10

11















12

Setting Mode

Test Mode

Troubleshooting

7. Operation

Item order	Item name (Display in Setting Item Selection Mode)	Item	Reference page
1		Number of coins per game	Page 53
2		Number of plays per game	Page 54
3		Big Bang Mode play time	Page 55
4		Normal Hockey Mode play time	Page 56
5		Mini puck supply frequency more/less setting for Big Bang Mode	Page 57
6		3-puck setting for Normal Hockey Mode	Page 58
7		Attract BGM ON/OFF	Page 59
8		Mini puck low warning ON/OFF	Page 60
9		Error log	Page 61
10		Ticket dispenser use setting	Page 63
11		Number of tickets paid to winner * This is displayed only when the ticket dispenser use setting is "on". (See "7-9-12 Number of Tickets Paid to Winner" on page 64.)	Page 64
12		Number of tickets paid to loser * This is displayed only when the ticket dispenser use setting is "on". (See "7-9-13 Number of Tickets Paid to Loser" on page 65.)	Page 65
13		Number of tickets paid in case of a tie * This is displayed only when the ticket dispenser use setting is "on". (See "7-9-14 Number of Tickets Paid in case of a Tie" on page 66.)	Page 66
14		Game mode setting	Page 67
15		Return all settings to default settings (factory settings)	Page 68

7-9-2 Number of coins per game

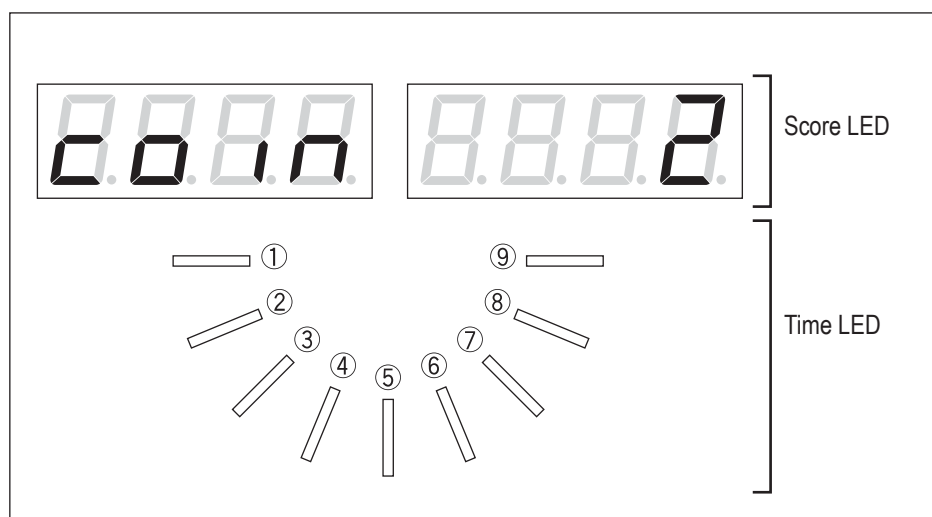

Setting item selection display (Number of coins per game)

- 1** In this Setting Item Selection Mode, “coin” is displayed in the left side score LED and the number of coins is displayed in the right side score LED.
- 2** Press the Enter button (green). The right side score LED display blinks and the machine enters the Setting Change Mode.
- 3** In the Setting Change Mode, flip the Select switch up and down to change the value.
 - The values that can be set are FrEE, 1, 2, 3, 4, 5, 6, 7, 8, 9, 10, 11, 12, 13, 14, 15, 16, 17, 18 and 19.
 - Flip the Select switch up to increase the value. The value returns to FrEE after 19.
 - Flip the Select switch down to decrease the value. The value returns to 19 after FrEE.
 - Set “FrEE” to set the Free Play Mode.
 * The default setting (factory setting) is “2”.
- 4** Press the Enter button (green) again to return to the Setting Item Selection Mode.

1

2

3

4

5

6

7

8A

8B

9

10

11

12

Setting Mode

Test Mode

Troubleshooting

7-9-3 Number of plays per game

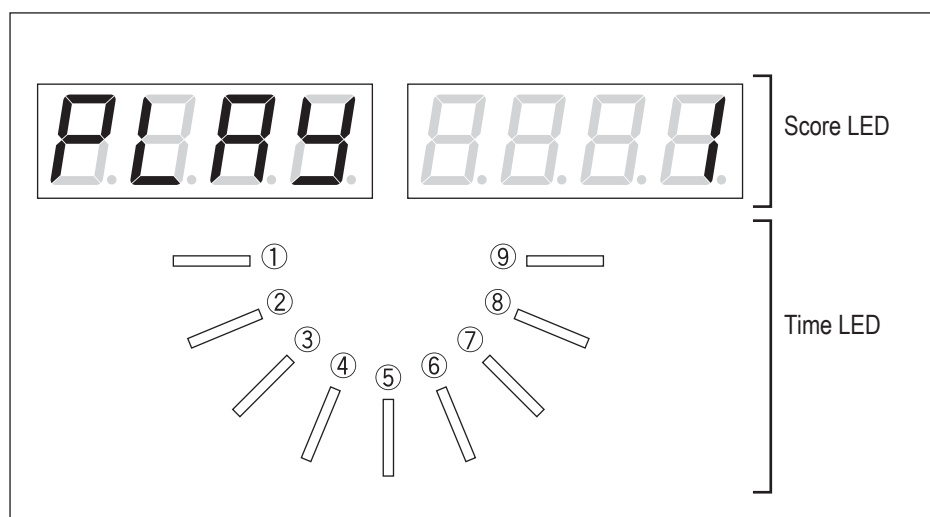

Setting item selection display (Number of plays per game)

- 1** In this Setting Item Selection Mode, "PLAY" is displayed in the left side score LED and the number of plays is displayed in the right side score LED.
- 2** Press the Enter button (green). The right side score LED display blinks and the machine enters the Setting Change Mode.
- 3** In the Setting Change Mode, flip the Select switch up and down to change the value.
 - The values that can be set are 1, 2, 3, 4, 5, 6, 7, 8 and 9.
 - Flip the Select switch up to increase the value. The value returns to 1 after 9.
 - Flip the Select switch down to decrease the value. The value returns to 9 after 1.
 * The default setting (factory setting) is "1".
- 4** Press the Enter button (green) again to return to the Setting Item Selection Mode.

7-9-4 Big Bang Mode play time

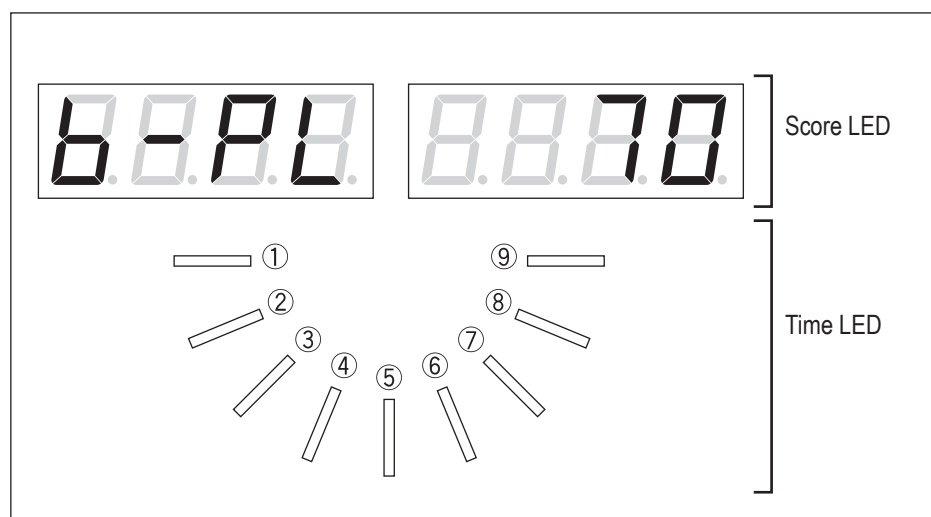

Setting item selection display (Big Bang Mode play time)

- 1** In this Setting Item Selection Mode, “b-PL” is displayed in the left side score LED and the play time (seconds) is displayed in the right side score LED.
- 2** Press the Enter button (green). The right side score LED display blinks and the machine enters the Setting Change Mode.
- 3** In the Setting Change Mode, flip the Select switch up and down to change the value.
 - The values that can be set are 60, 70, 80, 90, 100, 110, 120, 130, 140, 150, 160, 170, 180, 210, 240, 270 and 300.
 - Flip the Select switch up to increase the value. The value returns to 60 after 300.
 - Flip the Select switch down to decrease the value. The value returns to 300 after 60.
 - When a longer time is set than the Normal Hockey Mode play time, the Normal Hockey Mode play time is changed to the same time as the Big Bang Mode play time.

* The default setting (factory setting) is “70”.
- 4** Press the Enter button (green) again to return to the Setting Item Selection Mode.
*In Big Bang Mode, the set time may be extended slightly depending on the goal status.

1

2

3

4

5

6

7

8A

8B

9

10

11

12

Setting Mode

Test Mode

Troubleshooting

7-9-5 Normal Hockey Mode play time

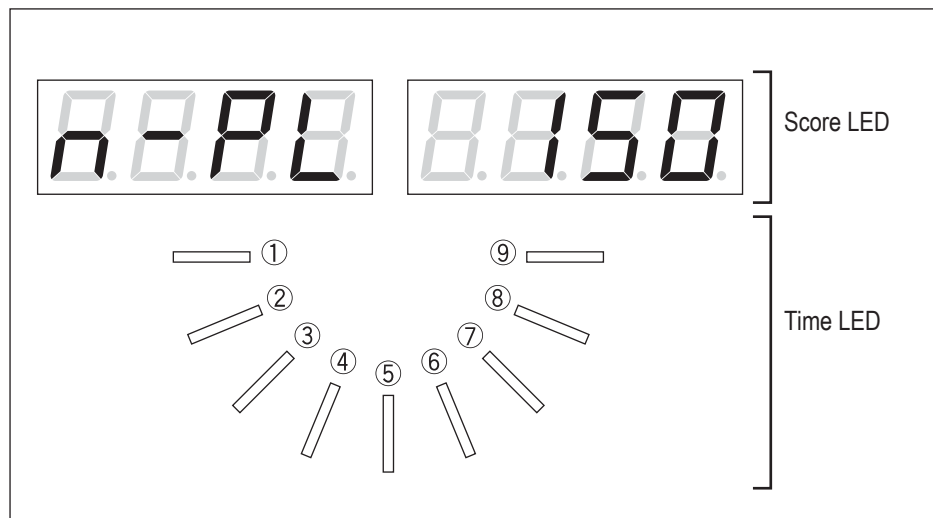

Setting item selection display (Normal Hockey Mode play time)

- 1** In this Setting Item Selection Mode, “n-PL” is displayed in the left side score LED and the play time (seconds) is displayed in the right side score LED.
- 2** Press the Enter button (green). The right side score LED display blinks and the machine enters the Setting Change Mode.
- 3** In the Setting Change Mode, flip the Select switch up and down to change the value.
 - The values that can be set are 60, 70, 80, 90, 100, 110, 120, 130, 140, 150, 160, 170, 180, 210, 240, 270, 300, 330, 360, 390, 420, 450, 480, 510, 540, 570 and 600. However, a time shorter than the Big Bang Mode play time cannot be set.
 - Flip the Select switch up to increase the value. The value returns to the Big Bang Mode play time (minimum time) after 600.
 - Flip the Select switch down to decrease the value. The value returns to 600 after the Big Bang Mode play time (minimum time).

* The default setting (factory setting) is “150”.
- 4** Press the Enter button (green) again to return to the Setting Item Selection Mode.

7-9-6 Mini puck supply frequency more/less setting for Big Bang Mode

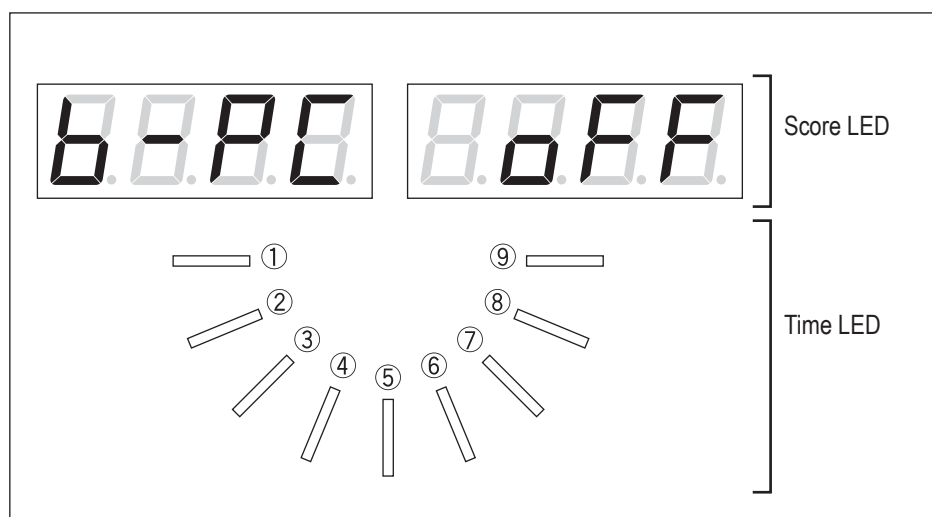

Setting item selection display (Mini puck supply frequency more/less setting for Big Bang Mode)

- 1** In this Setting Item Selection Mode, "b-PC" is displayed in the left side score LED and "oFF" or "on" is displayed in the right side score LED.
- 2** Press the Enter button (green). The right side score LED display blinks and the machine enters the Setting Change Mode.
- 3** In the Setting Change Mode, flip the Select switch up and down to change the value.
 - The values that can be set are "on" (more) and "oFF" (less).
 - * The default setting (factory setting) is "oFF" (less).
- 4** Press the Enter button (green) again to return to the Setting Item Selection Mode.

1

2

3

4

5

6

7

8A

8B

9

10

11

12

Setting Mode

Test Mode

Troubleshooting

7-9-7 3-puck setting for Normal Hockey Mode

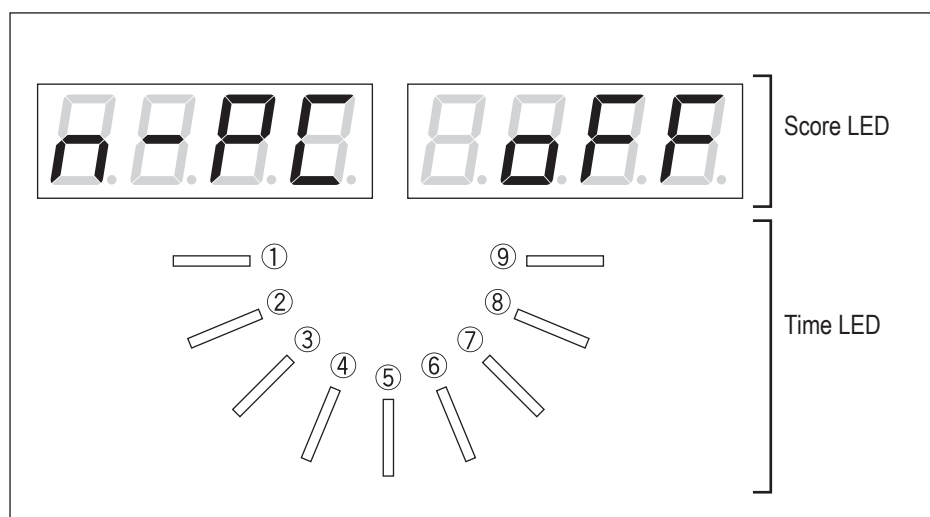

Setting item selection display (3-puck setting for Normal Hockey Mode)

- 1** In this Setting Item Selection Mode, “n-PC” is displayed in the left side score LED and “oFF” or “on” is displayed in the right side score LED.
- 2** Press the Enter button (green). The right side score LED display blinks and the machine enters the Setting Change Mode.
- 3** In the Setting Change Mode, flip the Select switch up and down to change the value.
 - The values that can be set are “oFF” (1 puck) and “on” (maximum 3 pucks).
 - *The default setting (factory setting) is “oFF” (1 puck).
 - *Even when set to “on”, three pucks may not be released depending on the time setting.
- 4** Press the Enter button (green) again to return to the Setting Item Selection Mode.

7-9-8 Attract BGM ON/OFF

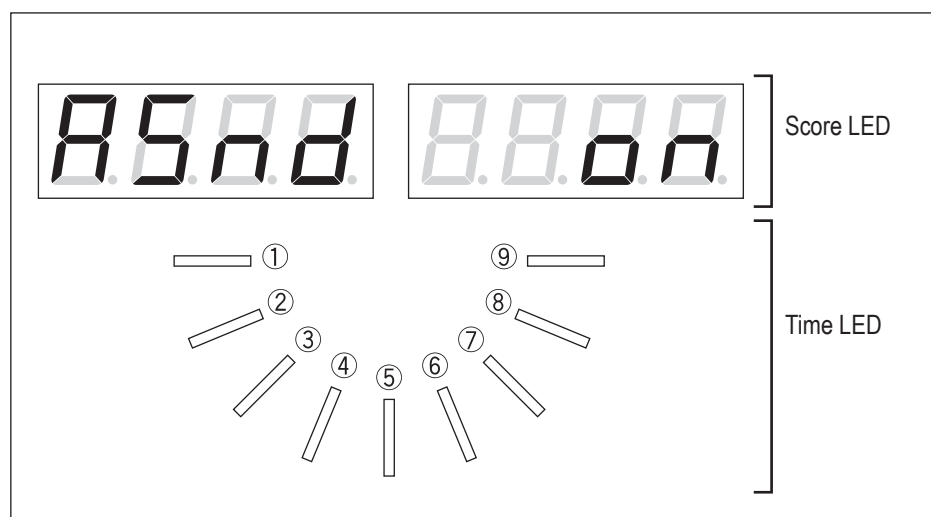

Setting item selection display (Attract BGM ON/OFF)

- 1** In this Setting Item Selection Mode, "ASnd" is displayed in the left side score LED and "on" or "oFF" is displayed in the right side score LED.
- 2** Press the Enter button (green). The right side score LED display blinks and the machine enters the Setting Change Mode.
- 3** In the Setting Change Mode, flip the Select switch up and down to change the value.
 - The values that can be set are "oFF" (Attract BGM off) and "on" (Attract BGM on).
 - * The default setting (factory setting) is "on" (Attract BGM on).
- 4** Press the Enter button (green) again to return to the Setting Item Selection Mode.

- 1
- 2
- 3
- 4
- 5
- 6
- 7
- 8A
- 8B
- 9
- 10
- 11
- 12

Setting Mode

Test Mode

Troubleshooting

7-9-9 Mini puck low warning ON/OFF

This function informs when the number of mini pucks has decreased.

* When the number of mini pucks decreases by 50 pucks or more during game operation due to loss or other reasons, the 4-digit score in the left side score LED blinks while the machine is in the standby state to inform that the number of mini pucks has decreased.

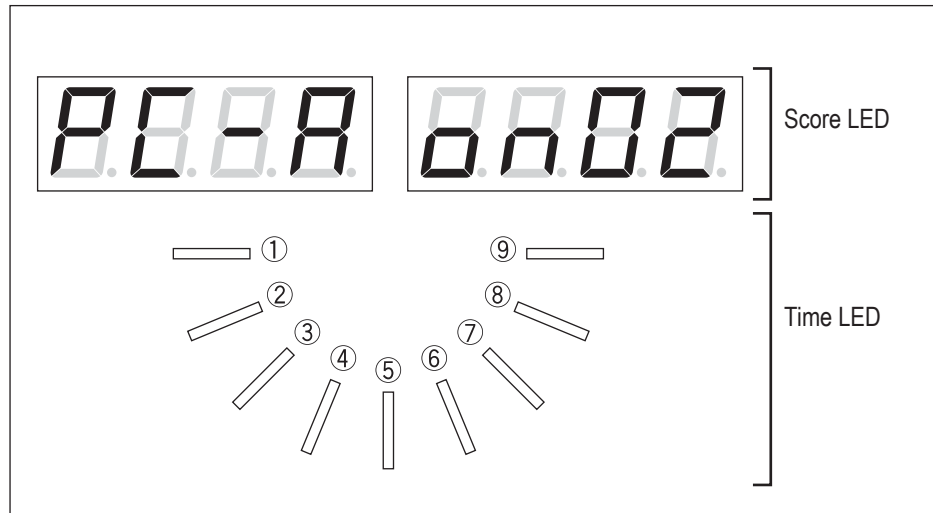

Setting item selection display (Mini puck low warning ON/OFF)

- 1** In this Setting Item Selection Mode, "PC-A" is displayed in the left side score LED and warning "on/off" and the mini puck decrease count is displayed in the right side score LED.
- 2** Press the Enter button (green). The right side score LED display blinks and the machine enters the Setting Change Mode.
- 3** In the Setting Change Mode, flip the Select switch up and down to change the setting.
 - The values that can be set are "oFF" (warning off) and "on" (warning on).
 - When set to "on", the right two digits of the right side score LED display the mini puck decrease count (number of mini pucks supplied to the playing field - number of mini pucks that have entered the goals). Values less than 0 are displayed as 0, and values greater than 99 are displayed as 99.
 - To reset the mini puck decrease count to 0, press the Service button (red) in the Setting Change Mode.
 - The mini puck decrease count is also reset to 0 when the setting value is changed from "on" to "oFF".

* The default setting (factory setting) is "on" (warning on).
- 4** Press the Enter button (green) again to return to the Setting Item Selection Mode.

NOTICE

- Make sure that there are ten mini pucks in each of the right and left sides of the mini puck stock area before resetting the mini puck decrease count. (See "7-8-7 S Hopper Motor ON/OFF Test and Sensor Check" on page 48.)
- Be sure to press the Service switch (red) and reset the mini puck decrease count to 0 when starting up the game for the first time or when adding mini pucks.

7-9-10 Error log

(1) Number of Errors Saved in Error Log Display Mode

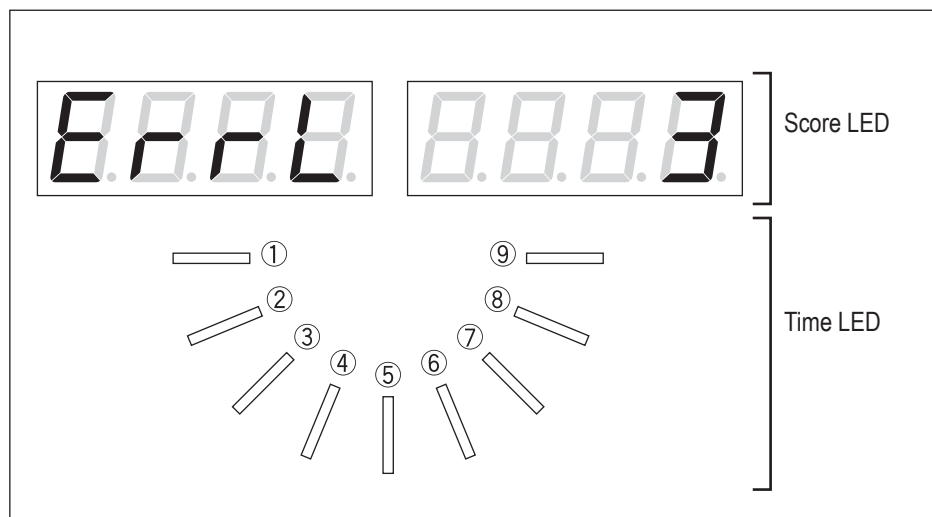

Setting item selection display (Error log)

- 1** In this Setting Item Selection Mode, "ErrL" is displayed in the left side score LED and the number of errors saved in the error log is displayed in the right side score LED.
- 2** Press the Enter button (green) to enter the Error Log Contents Display Mode that displays the errors saved in the error log.
 - * The default setting (factory setting) is "0".
 - * The machine can save up to twenty error log entries.

Setting Mode

Test Mode

Troubleshooting

(2) Error Log Contents Display Mode

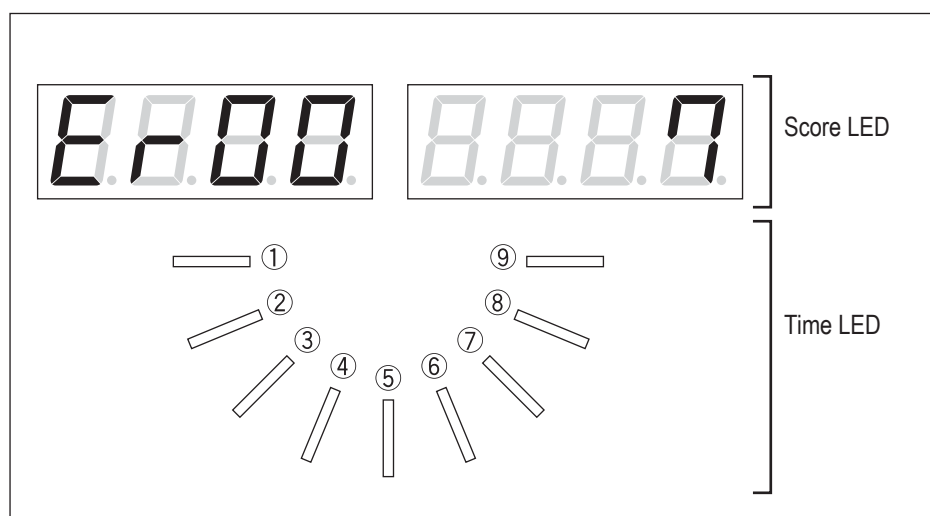

Setting item selection display (Error log contents display mode)

- 1** “Er00” to “Er19” is displayed in the left side score LED, and the corresponding error code saved in the error log is displayed in the right side score LED.
 - An error code of “0” indicates that no error is saved.
 - “Err00” is the newest error, and the errors become progressively older as the value increases.
- 2** Flip the Select switch up and down to change the value.
 - Flip the Select switch up to increase the value. The value returns to Er00 after Er19.
 - Flip the Select switch down to decrease the value. The value returns to Er19 after Er00.
- 3** Press the Service button (red) in this error log contents display mode to clear the entire error log.
- 4** Press the Enter button (green) again to return to the Setting Item Selection Mode.

7-9-11 Ticket Dispenser Use Setting

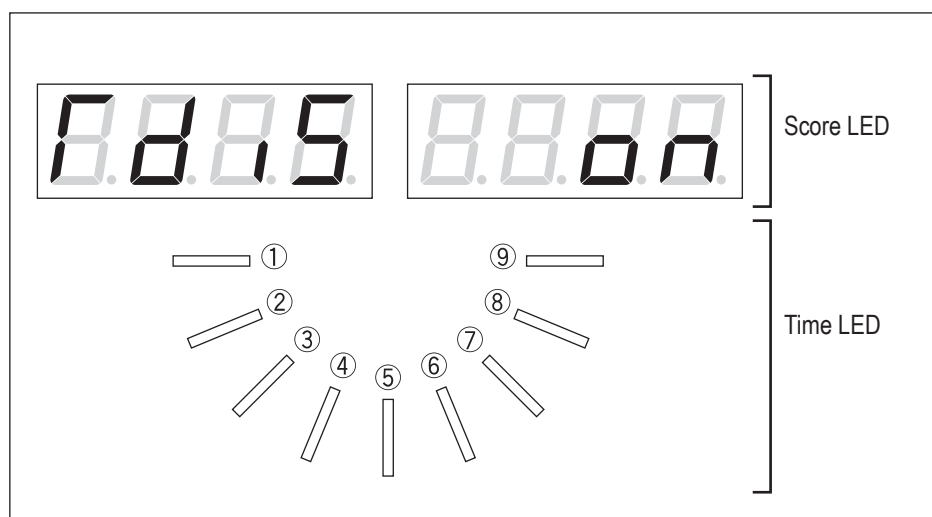

Setting item selection display (Ticket dispenser use setting)

- 1** In this Setting Item Selection Mode, "TdiS" is displayed in the left side score LED, and "on" or "oFF" is displayed in the right side score LED.
- 2** Press the Enter button (green). The right side score LED display blinks and the machine enters the Setting Change Mode.
- 3** In the Setting Change Mode, flip the Select switch up and down to change the value.
 - The values that can be set are "oFF" (Ticket dispenser not used) and "on" (Ticket dispenser used).
 - * The default setting (factory setting) is "oFF" (Ticket dispenser not used).
- 4** Press the Enter button (green) again to return to the Setting Item Selection Mode.

1

2

3

4

5

6

7

8A

8B

9

10

11

12

Setting Mode

Test Mode

Troubleshooting

7-9-12 Number of Tickets Paid to Winner

* This item is displayed only when the ticket dispenser use setting is "on".
(See "7-9-11 Ticket Dispenser Use Setting" on page 63.)

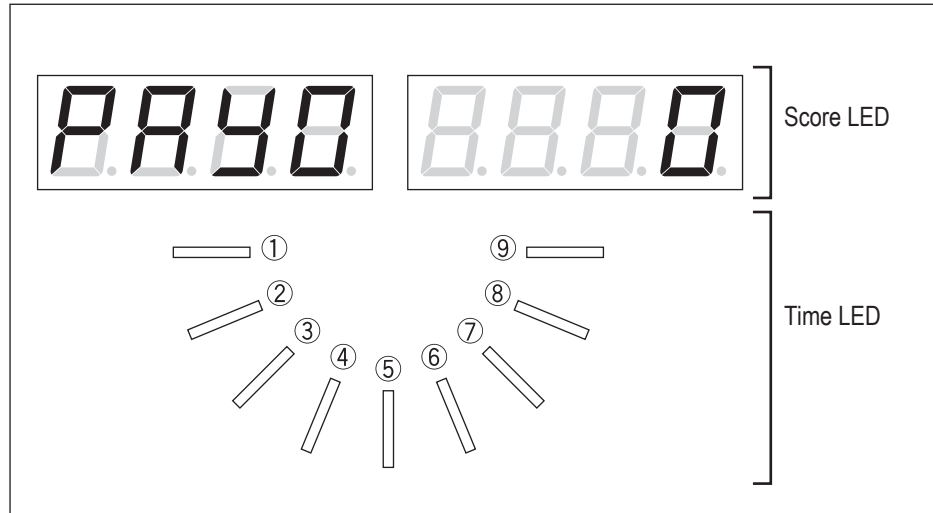

Setting item selection display (Number of tickets paid to winner)

- 1** In this Setting Item Selection Mode, "PAy0" is displayed in the left side score LED, and the number of tickets paid to the winner is displayed in the right side score LED.
- 2** Press the Enter button (green). The right side score LED display blinks and the machine enters the Setting Change Mode.
- 3** In the Setting Change Mode, flip the Select switch up and down to change the value.
 - The values that can be set are 0, 1, ..., 49 and 50.
 - Flip the Select switch up to increase the value. The value returns to 0 after 50.
 - Flip the Select switch down to decrease the value. The value returns to 50 after 0.
 - When a value less than the number of tickets paid to the loser is set, the number of tickets paid to the loser is changed to the same value as the number of tickets paid to the winner.
 - When a value less than the number of tickets paid in case of a tie is set, the number of tickets paid in case of a tie is changed to the same value as the number of tickets paid to the winner.

* The default setting (factory setting) is "0".
- 4** Press the Enter button (green) again to return to the Setting Item Selection Mode.

7-9-13 Number of Tickets Paid to Loser

* This item is displayed only when the ticket dispenser use setting is "on".
(See "7-9-11 Ticket Dispenser Use Setting" on page 63.)

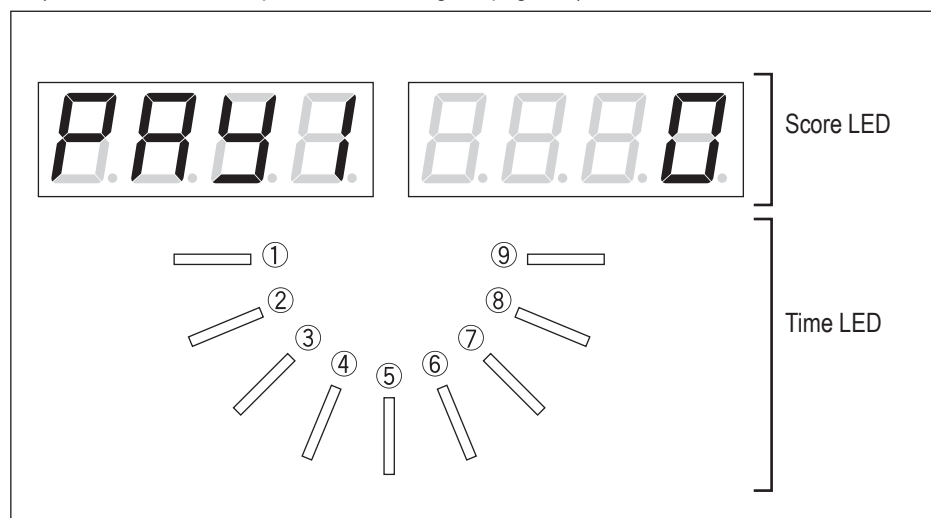

Setting item selection display (Number of tickets paid to loser)

- 1** In this Setting Item Selection Mode, "PAY1" is displayed in the left side score LED, and the number of tickets paid to the loser is displayed in the right side score LED.
- 2** Press the Enter button (green). The right side score LED display blinks and the machine enters the Setting Change Mode.
- 3** In the Setting Change Mode, flip the Select switch up and down to change the value.
 - The values that can be set are 0, 1, ..., 49 and 50.
 - However, a value greater than the number of tickets paid to the winner cannot be set.
 - Flip the Select switch up to increase the value. The value returns to 0 after the number of tickets paid to the winner.
 - Flip the Select switch down to decrease the value. The value returns to the number of tickets paid to the winner after 0.
 - When a value greater than the number of tickets paid in case of a tie is set, the number of tickets paid in case of a tie is changed to the same value as the number of tickets paid to the loser.

* The default setting (factory setting) is "0".
- 4** Press the Enter button (green) again to return to the Setting Item Selection Mode.

1

2

3

4

5

6

7

8A

8B

9

10

11

12

Setting Mode

Test Mode

Troubleshooting

7-9-14 Number of Tickets Paid in case of a Tie

* This item is displayed only when the ticket dispenser use setting is "on".
(See "7-9-11 Ticket Dispenser Use Setting" on page 63.)

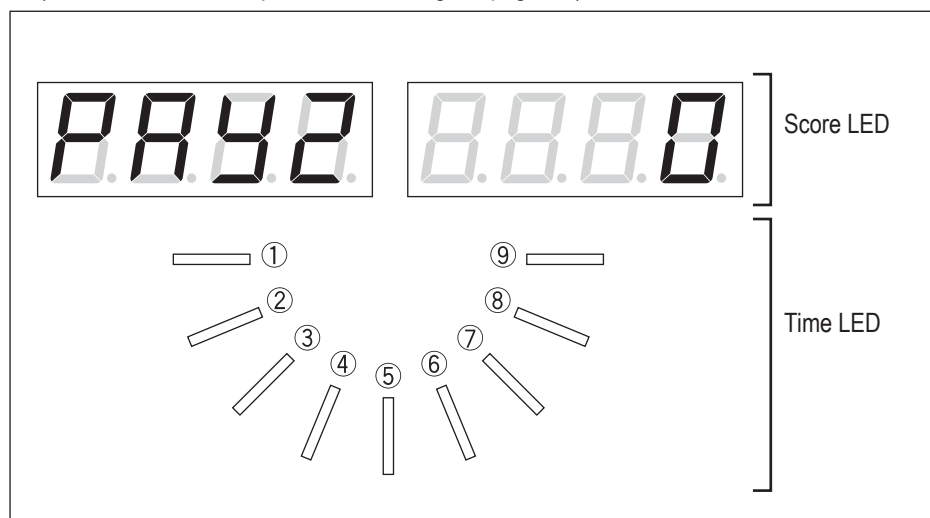

Setting item selection display (Number of tickets paid in case of a tie)

- 1** In this Setting Item Selection Mode, "PA2" is displayed in the left side score LED, and the number of tickets paid in case of a tie is displayed in the right side score LED.
- 2** Press the Enter button (green). The right side score LED display blinks and the machine enters the Setting Change Mode.
- 3** In the Setting Change Mode, flip the Select switch up and down to change the value.
 - The values that can be set are 0, 1, ..., 49 and 50.
 - However, a value greater than the number of tickets paid to the winner or less than the number of tickets paid to the loser cannot be set.
 - Flip the Select switch up to increase the value. The value returns to the number of tickets paid to the loser after the number of tickets paid to the winner.
 - Flip the Select switch down to decrease the value. The value returns to the number of tickets paid to the winner after the number of tickets paid to the loser.

* The default setting (factory setting) is "0".
- 4** Press the Enter button (green) again to return to the Setting Item Selection Mode.

7-9-15 Game mode setting

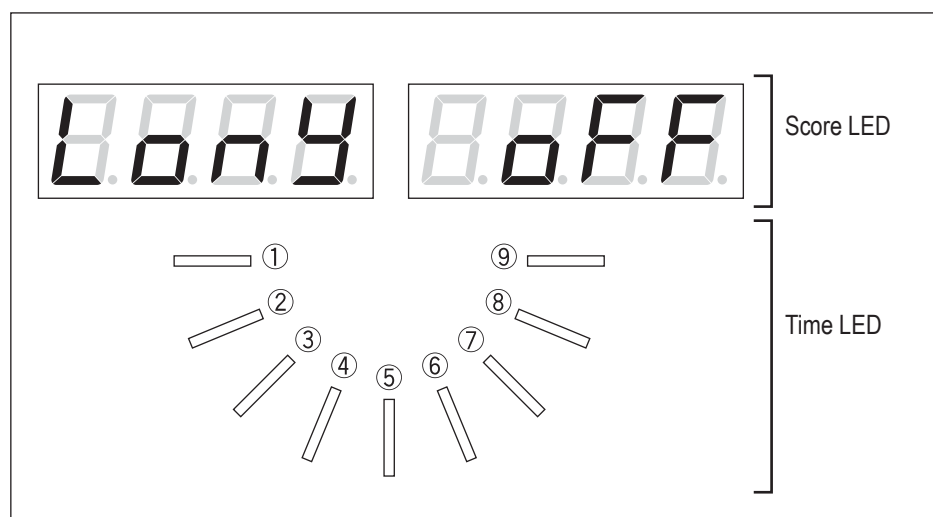

Setting item selection display (Game mode setting)

- 1** In this Setting Item Selection Mode, “Lony” is displayed in the left side score LED and “on” or “oFF” is displayed in the right side score LED.
- 2** Press the Enter button (green). The right side score LED display blinks and the machine enters the Setting Change Mode.
- 3** In the Setting Change Mode, flip the Select switch up and down to change the value.
 - The values that can be set are “oFF” (Big Bang Mode only) and “on” (Normal Hockey Mode only).
 - When set to “on” and required coins are inserted, game selection is not performed and the game starts in Normal Hockey Mode (using only big pucks). In addition, the mini puck related error checks are not performed.

* The default setting (factory setting) is “oFF” (Big Bang Mode only).
- 4** Press the Enter button (green) again to return to the Setting Item Selection Mode.

1

2

3

4

5

6

7

8A

8B

9

10

11

12

Setting Mode

Test Mode

Troubleshooting

7-9-16 Return all settings to default settings (factory settings)

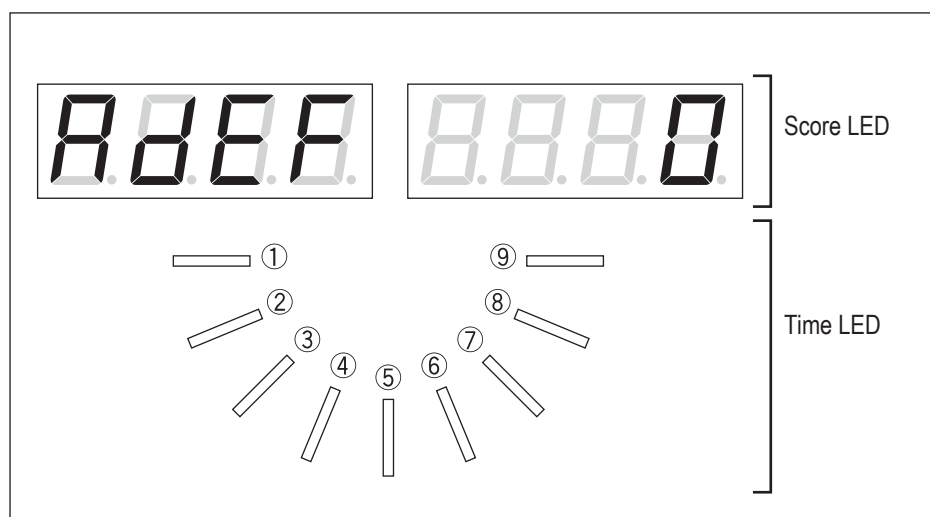

Setting item selection display (Return all settings to default settings (factory settings))

- 1** In this Setting Item Selection Mode, “AdEF” is displayed in the left side score LED and a value indicating whether the settings are the same as the default settings (factory settings) is displayed in the right side score LED.
 - The right side score LED displays “0” when the setting values are the default settings (factory settings), or “1” when there are settings other than the default settings (factory settings).
- 2** Press the Enter button (green). The value in the right side score LED starts to blink.
- 3** If the Service switch (red) is pressed while the value in the right side score LED is blinking, all settings are returned to the default settings (factory settings) and the value changes to “0”.
- 4** If the Enter button (green) is pressed while the value in the right side score LED is blinking, the value stops blinking and the machine returns to the Setting Item Selection Mode.

* The error log and the mini puck decrease count are also cleared.

7-10 Mini Puck Low Warning and Adding Mini Pucks

7-10-1 Mini Puck Low Warning

When the mini puck low warning ON/OFF setting mode is set to ON and the number of mini pucks decreases by 50 or more, the 4-digit score in the left side score LED (signboard) blinks while the machine is in the standby state.



- When this blinking is confirmed, add mini pucks.

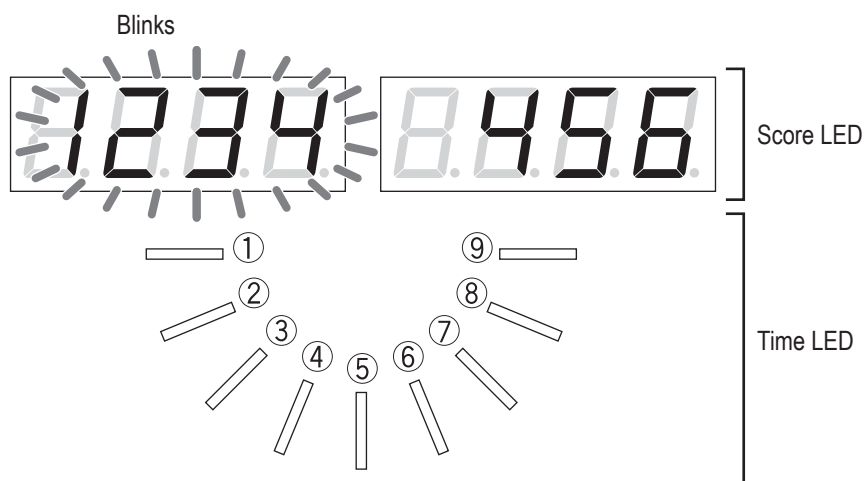

7-10-2 Adding Mini Pucks

When the mini puck low warning is displayed or the number of mini pucks is otherwise confirmed to have decreased, follow the procedure below to add mini pucks.

- 1 Block the goals so that mini pucks cannot enter.
- 2 Use Test mode and release all of the mini pucks to the playing field. (See “7-8-7 S Hopper Motor ON/OFF Test and Sensor Check” on page 48.)
- 3 Count the number of mini pucks, and add mini pucks so that there is a total of 120 pucks.
- 4 Unblock the goal (L) so that the mini pucks can enter.
- 5 Put the mini pucks into the goal (L).



- Put the mini pucks into the goal (L) one to three pucks at a time. If many pucks are put into the goal at once, the pucks may become jammed inside the machine and prevent normal operation.
 - Be sure to put the mini pucks into the goal (L).
- 6 Reset the decrease count of the mini puck low warning to “0”. (See “7-9-9 Mini puck low warning ON/OFF” on page 60.)

1

2

3

4

5

6

7

8A

8B

9

10

11

12

Mini Puck Low Warning and Adding Mini Pucks

Test Mode

Troubleshooting

7-11 Daily Cleaning

7-11-1 Cleaning the Playing Field

NOTICE

- Be careful not to scratch the playing field when cleaning.
- Do not use thinner, benzene, gasoline, alcohol or other organic solvents. This may degrade the materials.
- Do not use wax or other substances that may block the air holes. The pucks will not slide well.
- If the air holes in the playing field become blocked by dust or dirt, the pucks will not slide well. Periodically clean the air holes in the playing field.

- 1** Wipe away any dirt using a soft cloth moistened with water or a neutral cleanser diluted with water and then firmly wrung out.

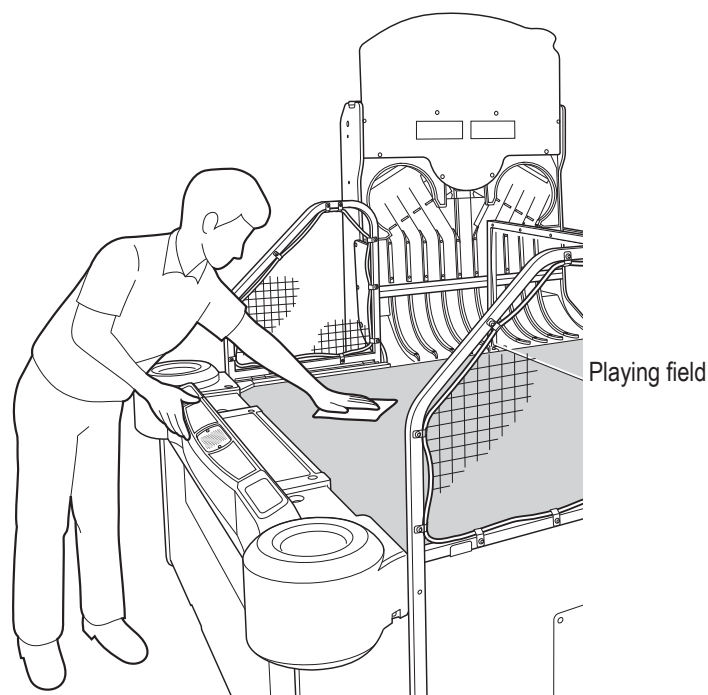

- 2** Wipe dry so that no detergent or water remains, and then allow to dry thoroughly.

- 3** When the air holes are clogged with dust or dirt, insert a paper clip or other pin-like object into the air holes and remove the dirt.

NOTICE

- Check the air holes by sliding a puck over the playing field in the condition with the blower fan rotating. If the puck does not slide well, remove any dust and dirt from the air holes.

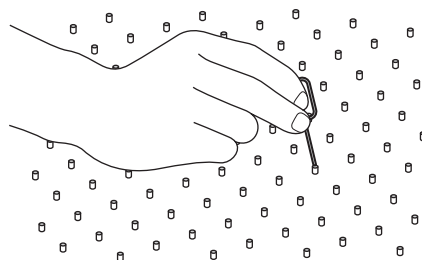

7-11-2 Cleaning the Goal Covers and Corner Covers



- Do not use thinner, benzene, gasoline, alcohol or other organic solvents. This may degrade the materials.

- 1 Wipe away any dirt using a soft cloth moistened with water or a neutral cleanser diluted with water and then firmly wrung out.

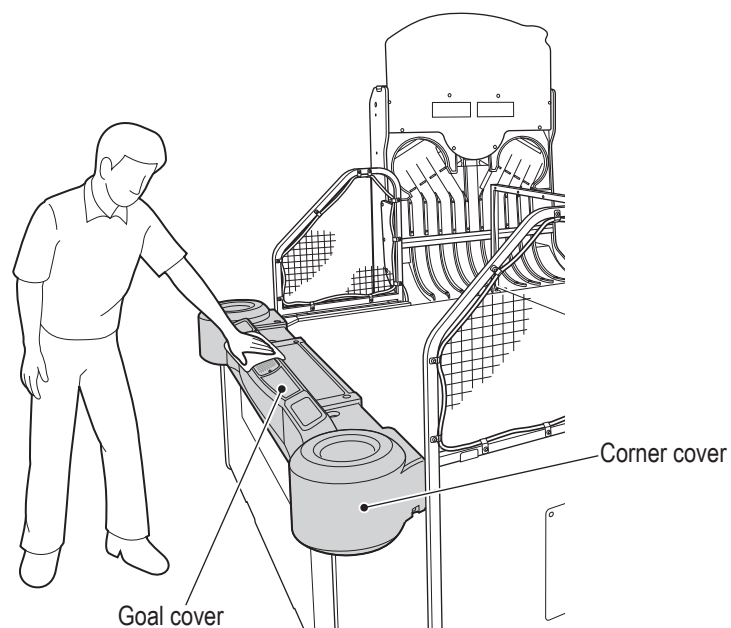

- 2 Wipe dry so that no detergent or water remains, and then allow to dry thoroughly.

7-11-3 Cleaning the Pucks and Mallets



- Do not use thinner, benzene, gasoline, alcohol or other organic solvents. This may degrade the materials.

- 1 Wipe away any dirt using a soft cloth moistened with water or a neutral cleanser diluted with water and then firmly wrung out.

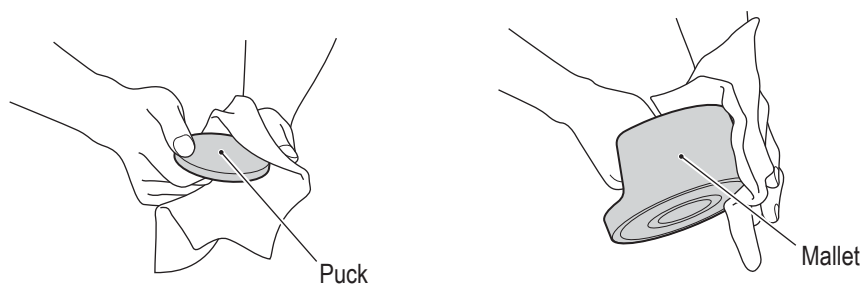

- 2 Wipe dry so that no detergent or water remains, and then allow to dry thoroughly.

1

2

3

4

5

6

7

8A

8B

9

10

11

12

Daily Cleaning

Test Mode

Troubleshooting

7-11-4 Cleaning the Signboard and Cover Panel



- Do not use thinner, benzene, gasoline, alcohol or other organic solvents. This may degrade the materials.

- 1** Wipe away any dirt using a soft cloth moistened with water or a neutral cleanser diluted with water and then firmly wrung out.

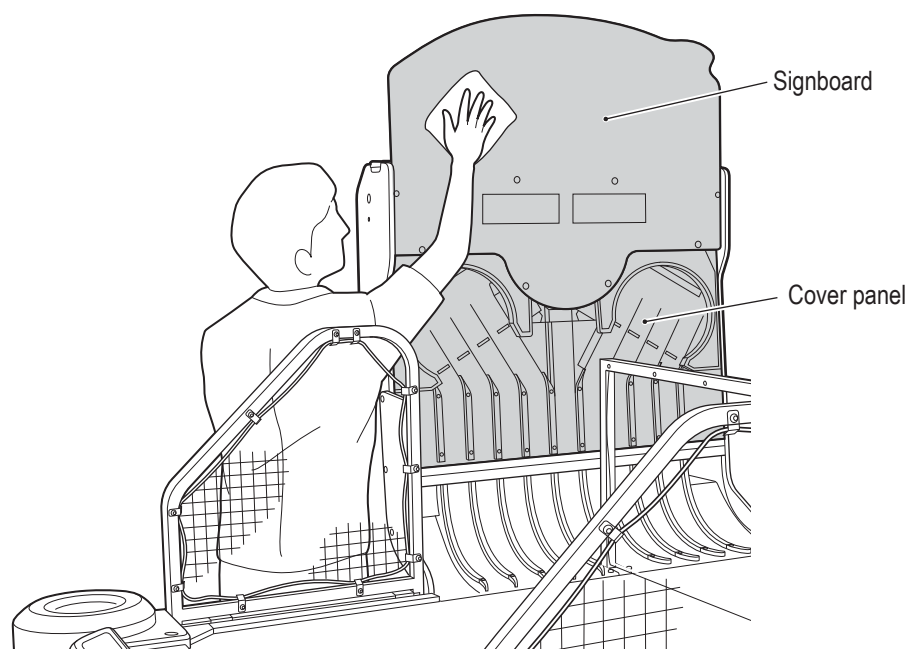

- 2** Wipe dry so that no detergent or water remains, and then allow to dry thoroughly.



7-11-5 Cleaning the Sloped Areas



● Do not use thinner, benzene, gasoline, alcohol or other organic solvents. This may degrade the materials.

- 1** Wipe away any dirt using a soft cloth moistened with water or a neutral cleanser diluted with water and then firmly wrung out.

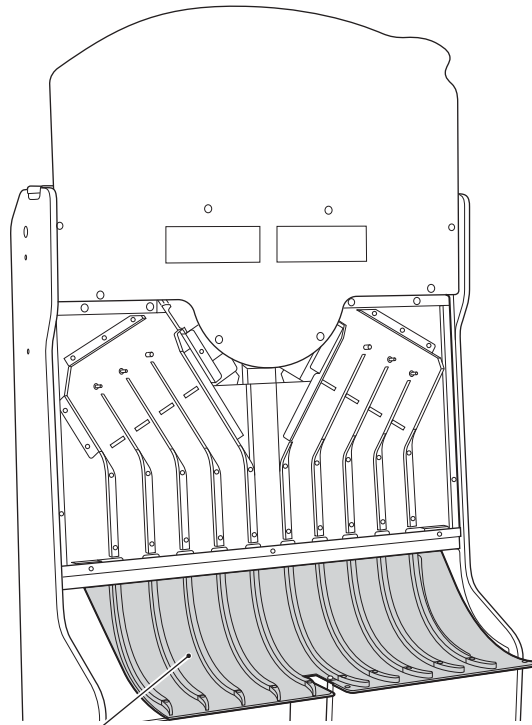

Sloped area

- 2** Wipe dry so that no detergent or water remains, and then allow to dry thoroughly.

- 1
- 2
- 3
- 4
- 5
- 6
- 7
- 8A
- 8B
- 9
- 10
- 11
- 12

Daily Cleaning

Test Mode

Troubleshooting

8. Technician's Manual - Must be performed by a technician -

8A. Installation and Assembly

8A-1 Number of Workers, Work Time and Work Space

8A-1-1 Number of Workers and Work Time

(1) Number of Workers

The work should be performed by four technicians.

(2) Work Time

The estimated work time for four workers (technicians) is 2 hours.

8A-1-2 Securing Work Space

Secure the following space around the cabinet for performing the installation work.

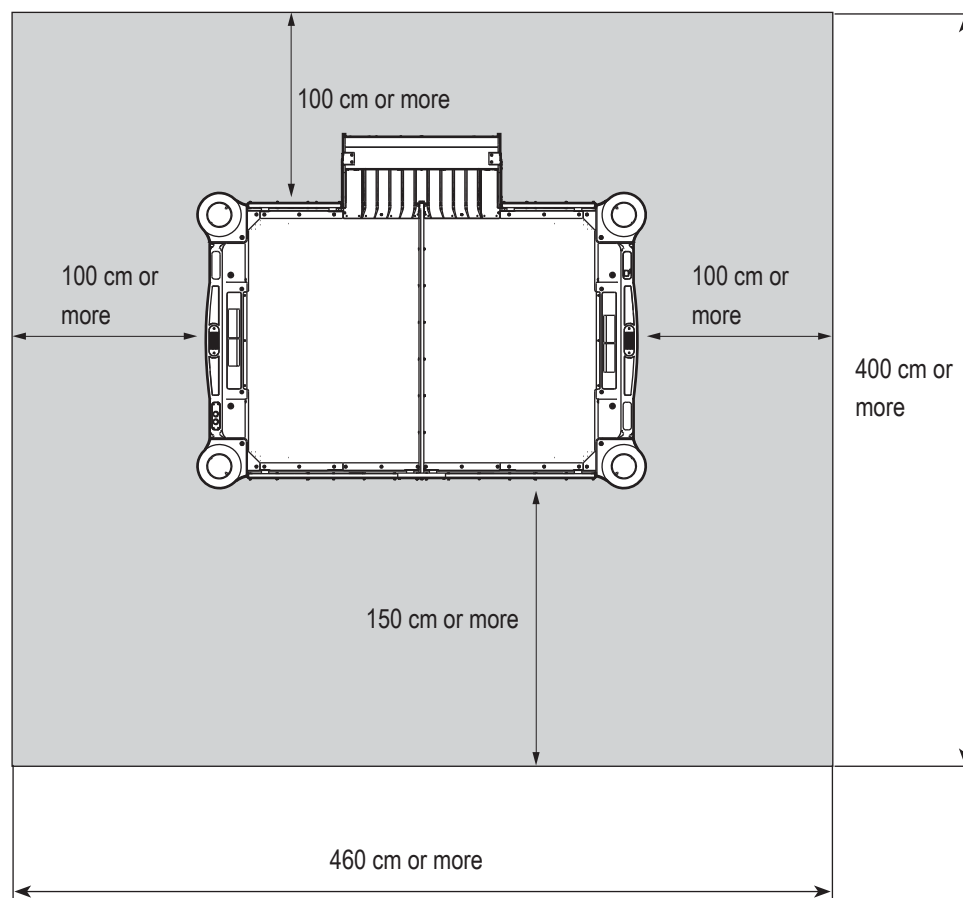



- Must be performed by a technician -

8A-2 Assembly

8A-2-1 Assembling the Table

(1) Assembling the Table, Goals and Corner Covers

- 1** Join the cabinet (L) and (R) assemblies with 10 Phillips hexagon socket head bolts (with flat and spring washers) (M8 x 35) and 10 square washers (M8), and connect the three connectors.

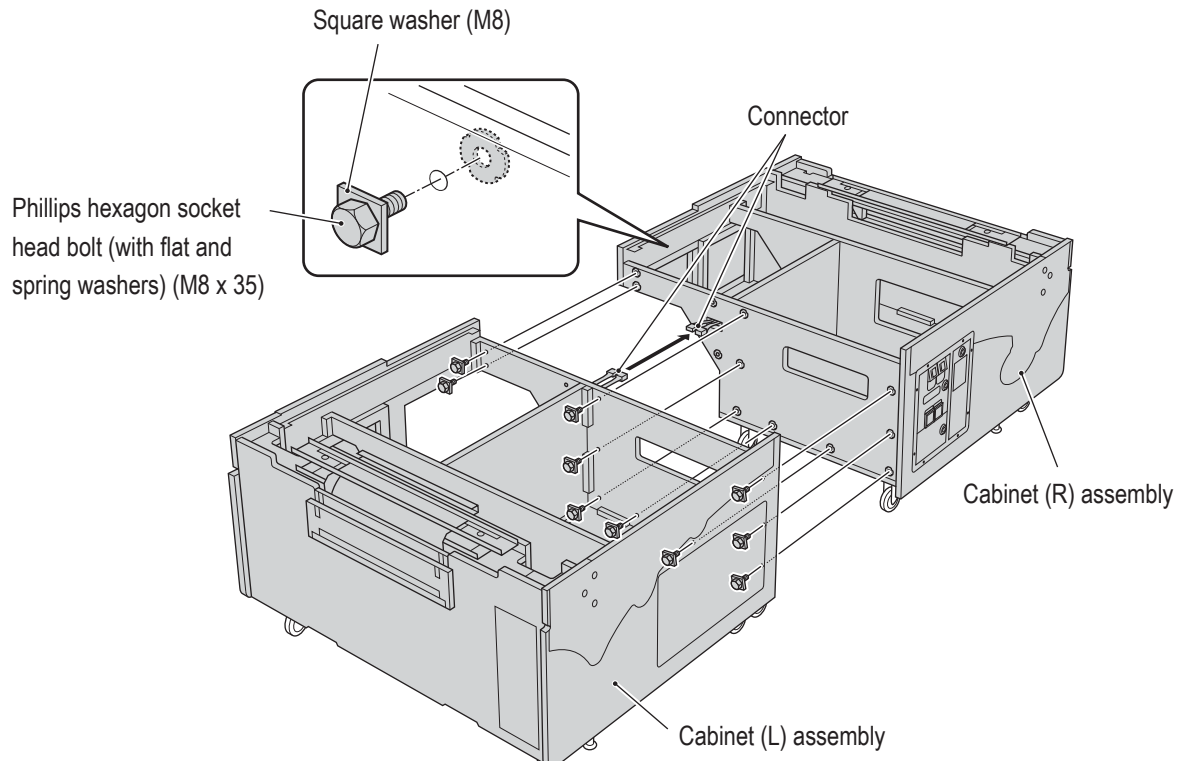

- 2** Open the coating clip, and release the bundled harness.

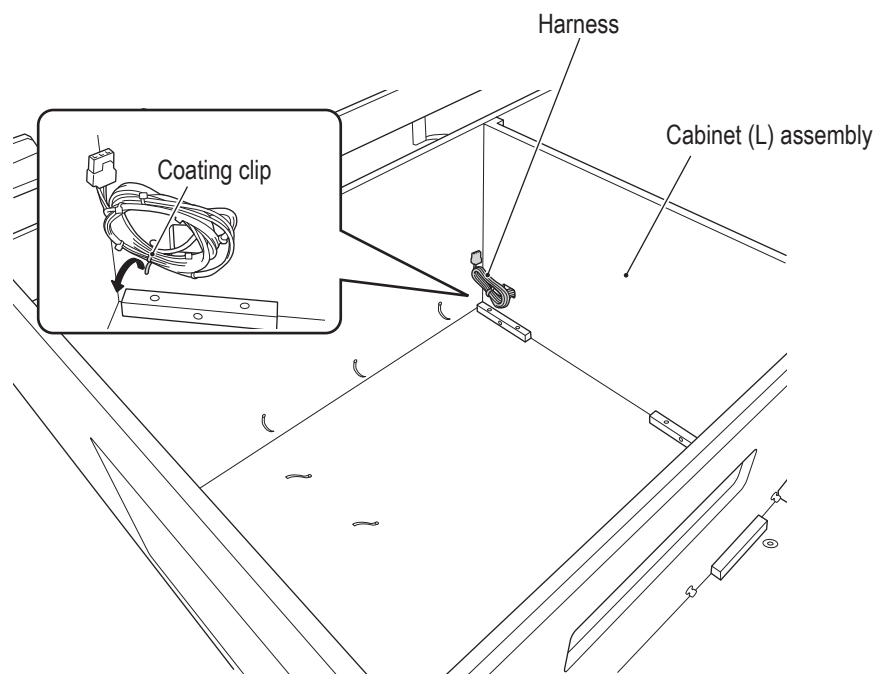

- 1
- 2
- 3
- 4
- 5
- 6
- 7
- 8A**
- 8B
- 9
- 10
- 11
- 12

Number of Workers, Work Time and Work Space/ Assembly

Test Mode

Troubleshooting

8A. Installation and Assembly

- Must be performed by a technician -

- 3 Attach the harness released in step 2 with the six coating clips as shown in the figure.

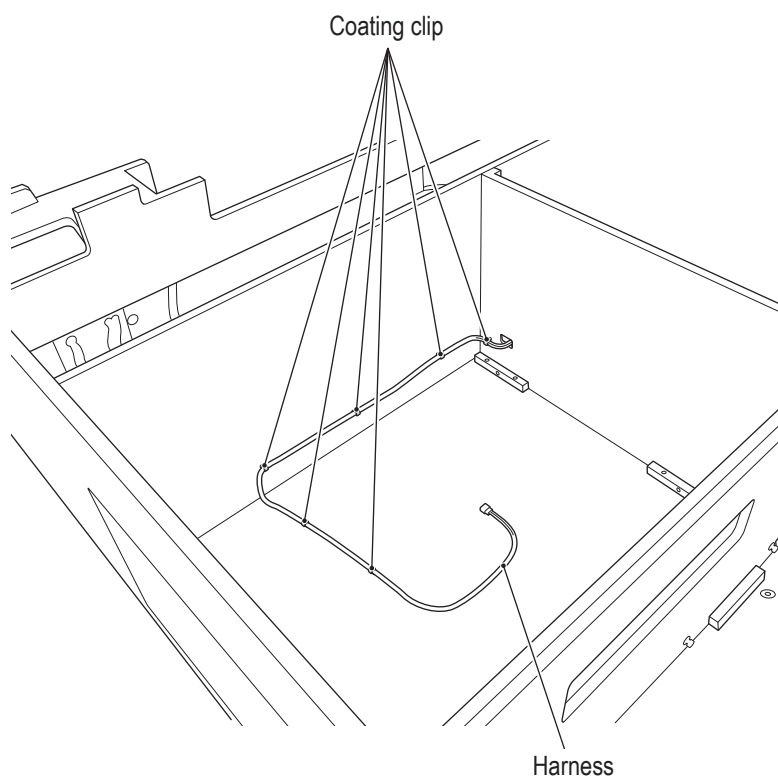

- 4 Open the goal (L) assembly. (See "7-5-3 Opening and Closing the Goal (L) and (R) Assemblies" on page 38.)

- 5 Lead out the two connectors through the holes, and secure them with the coating clips.

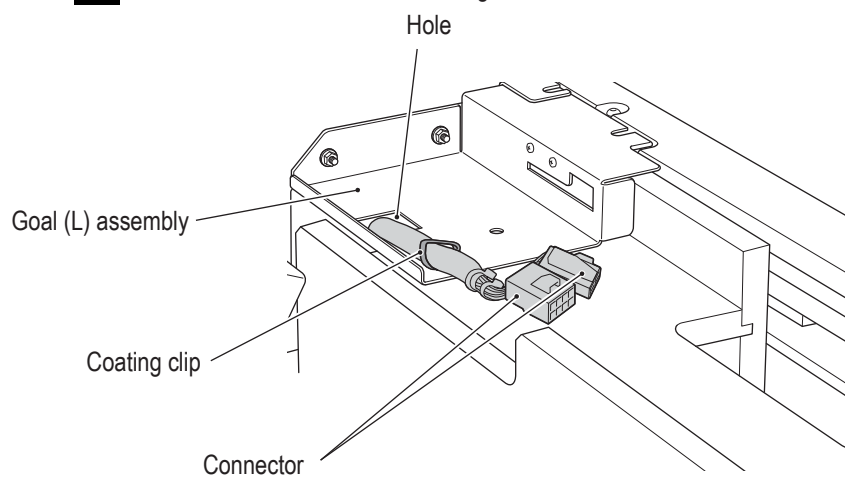



- Must be performed by a technician -

- 1
- 2
- 3
- 4
- 5
- 6
- 7
- 8A**
- 8B
- 9
- 10
- 11
- 12

Assembly

6 Remove the two flange socket bolts (M5 x 16).

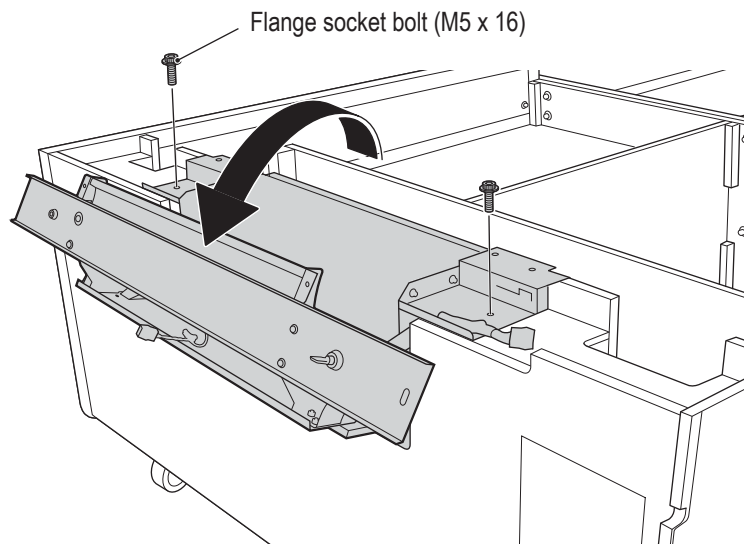

7 Close the goal (L) assembly. (See "7-5-3 Opening and Closing the Goal (L) and (R) Assemblies" on page 38.)

8 Lift the goal (L) assembly straight up with two people, and remove it.

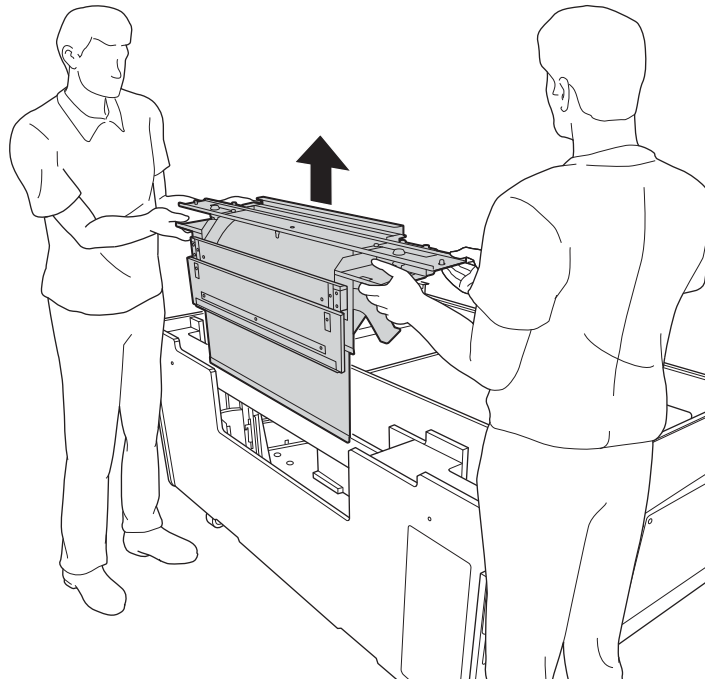

9 Follow the same procedure as steps **4** to **8** to remove the goal (R) assembly.

Test Mode

Troubleshooting



8A. Installation and Assembly

- Must be performed by a technician -

- 10** Attach the blower brackets (L) and (R) to the table top assembly with three flange socket bolts (M5 x 16) each.

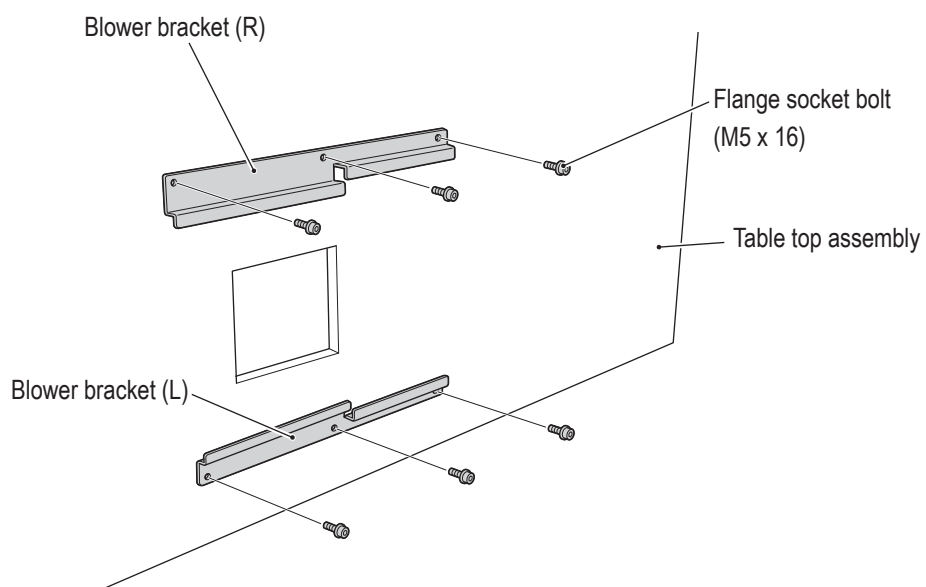

- Do not place the table top assembly on the floor or other location with the surface to which the blower brackets (L) and (R) are attached on the bottom. Doing so may cause the parts to deform.



- Must be performed by a technician -

- 1
- 2
- 3
- 4
- 5
- 6
- 7
- 8A
- 8B
- 9
- 10
- 11
- 12

Assembly

CAUTION

- When attaching the table top assembly, be careful where you place your hands to avoid trapping your hands.

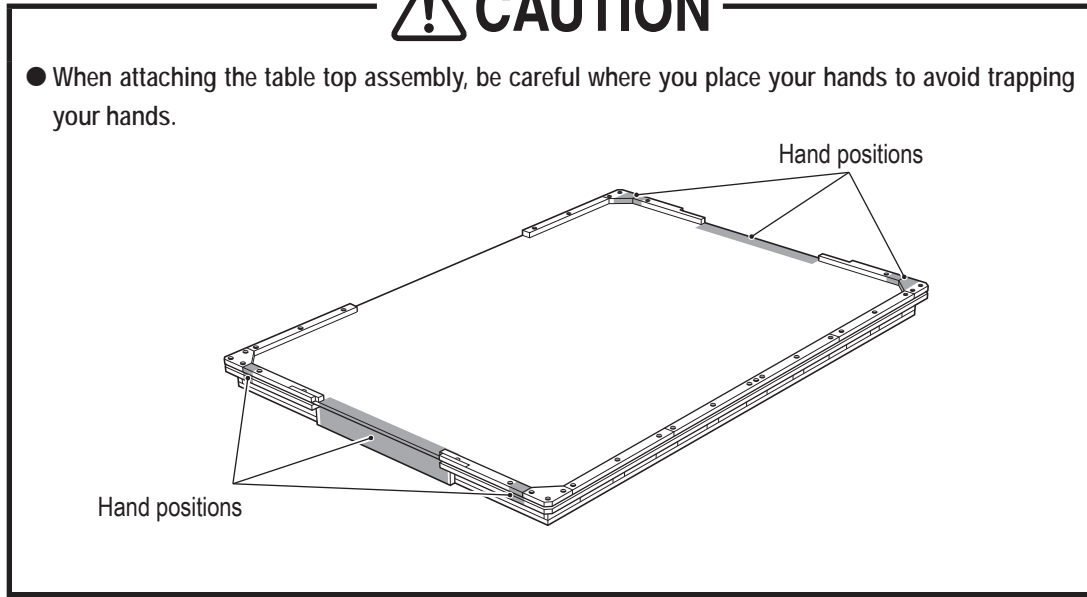

- 11** Lift up the table top assembly with four people as shown in the figure, and fit it onto the top of the cabinet assembled in step **1**.



- The table top assembly has an orientation. Assemble so that the area without the table bumper is on the same side as the opening in the cabinet.

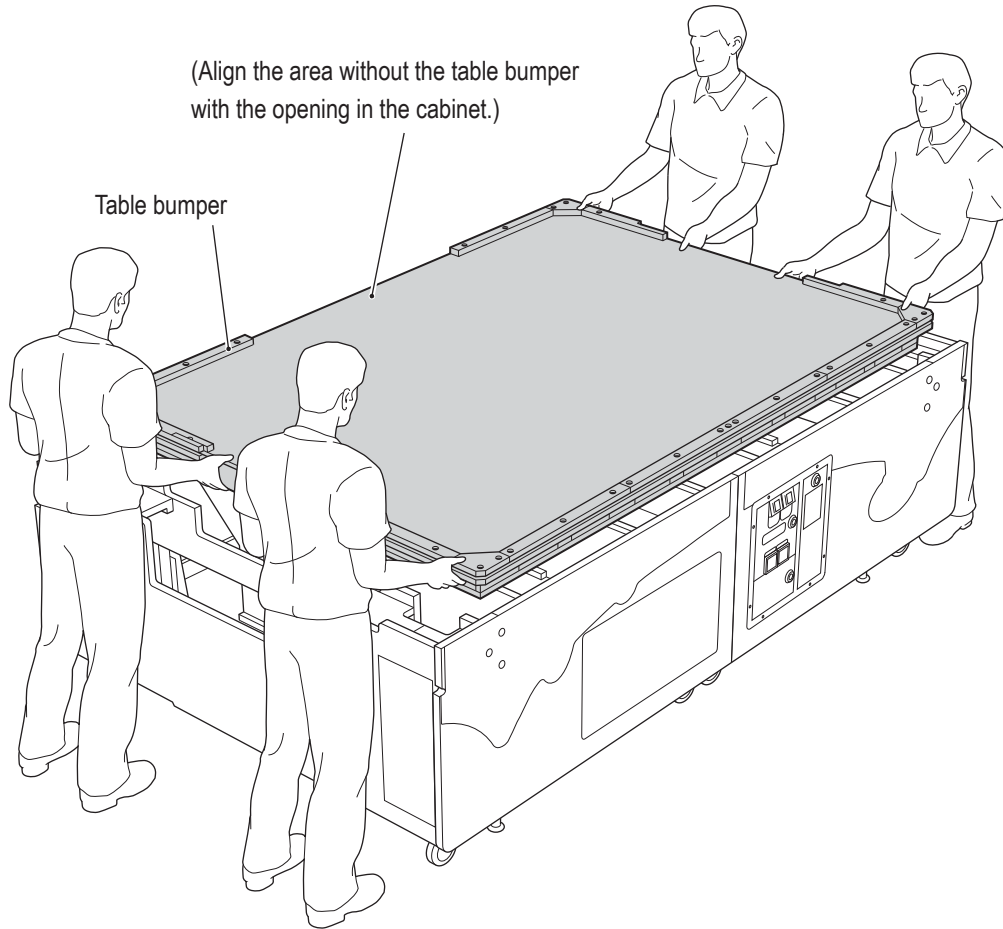

Test Mode

Troubleshooting

8A. Installation and Assembly

- Must be performed by a technician -

- 12** Attach the table top assembly to the cabinet with six button head bolts (M6 x 40) and six spring washers (M6).



- It may be difficult to attach the screws if the floor surface is not level. In this case, adjust the level adjusters so that the cabinet is level.

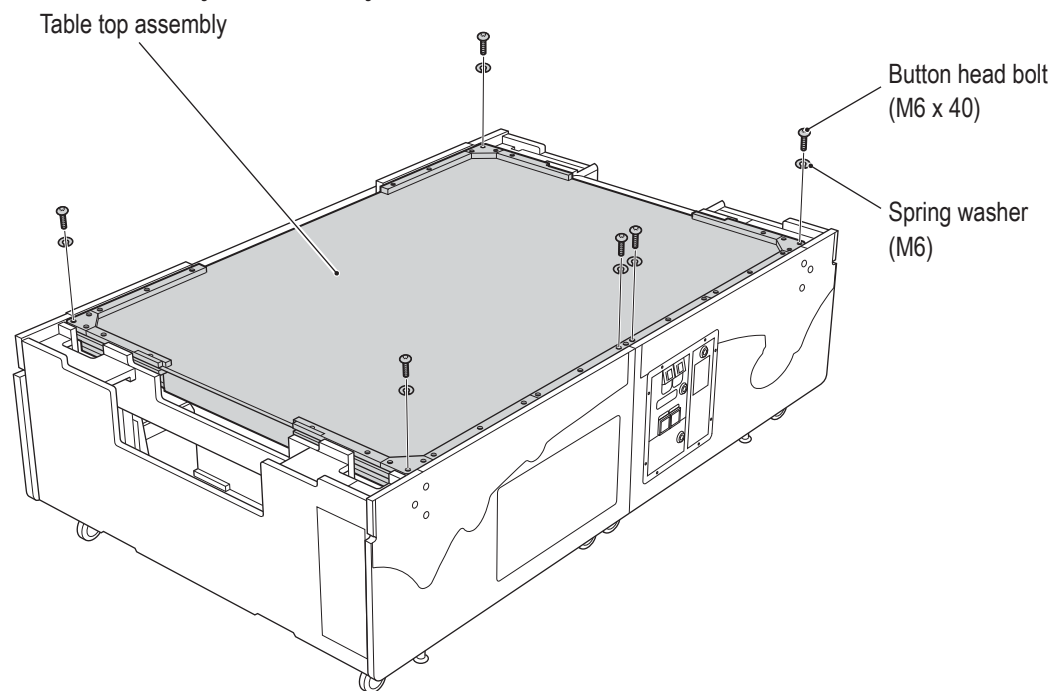

- 13** Insert the goal (L) and (R) assemblies removed in steps **8** and **9** into the cabinet from above. At this time, insert the lower edges of the goal (L) and (R) assemblies into the goal set brackets.

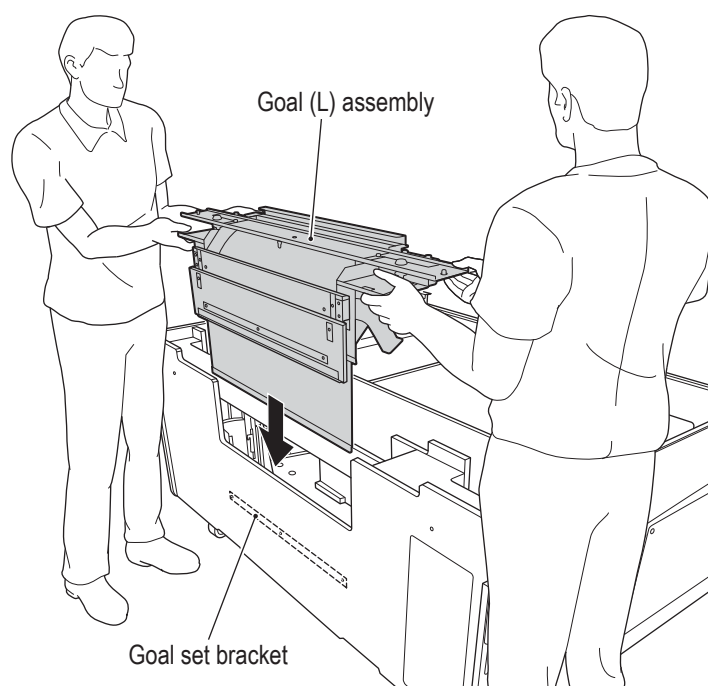

- 14** Open the goal (L) assembly. (See "7-5-3 Opening and Closing the Goal (L) and (R) Assemblies" on page 38.)



- Must be performed by a technician -

- 1
- 2
- 3
- 4
- 5
- 6
- 7
- 8A
- 8B
- 9
- 10
- 11
- 12

Assembly

15 Lead out and connect the two connectors through the holes, and secure them with the coating clips.



- Store the excess harness length below the holes so that there is no slack in the connected connectors and harnesses above the holes.

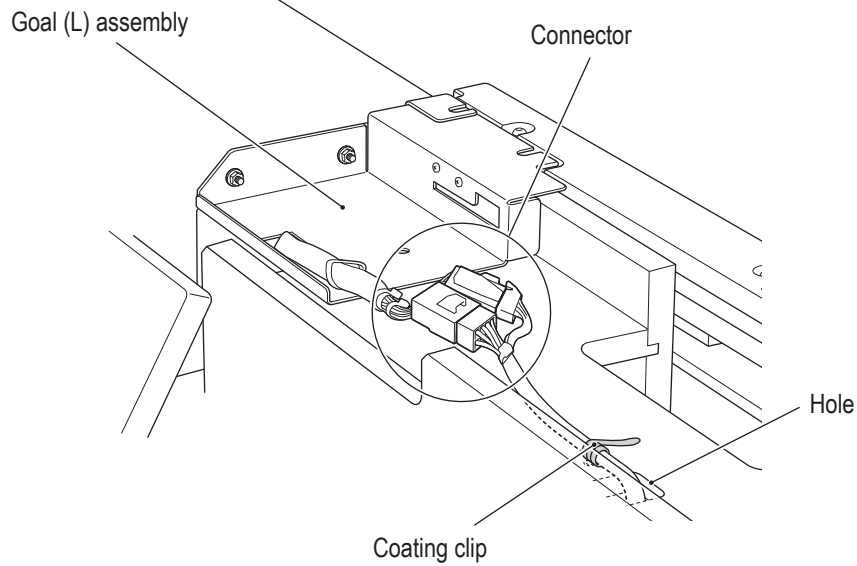

16 Temporarily secure the goal (L) assembly with the two flange socket bolts (M5 x 16) removed in step **6** and four flange socket bolt (M5 x 10).

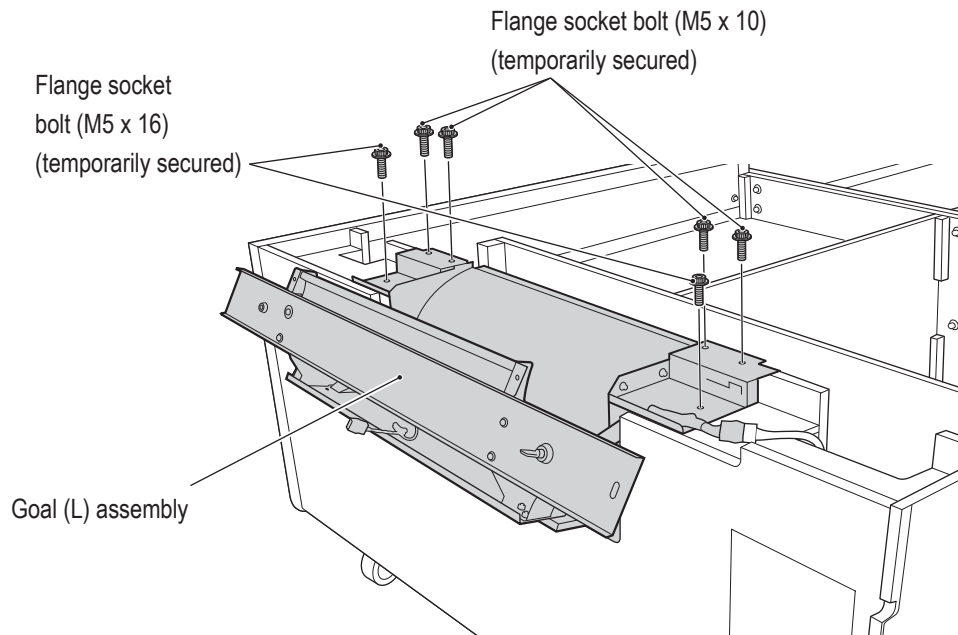

- When installing, be sure to use bolts of the specified length.
- When installing, be careful not to pinch the connectors.

17 Follow the same procedure as steps **14** to **16** to temporarily secure the goal (R) assembly.

Test Mode

Troubleshooting

8A. Installation and Assembly

- Must be performed by a technician -

- 18** Set the corner covers (red • L, red • R, blue • L and blue • R) on the respective corners of the cabinet, and secure them with two button head bolts (M6 x 40), one button head bolt (M6 x 25) and three flat washers (M6) each.

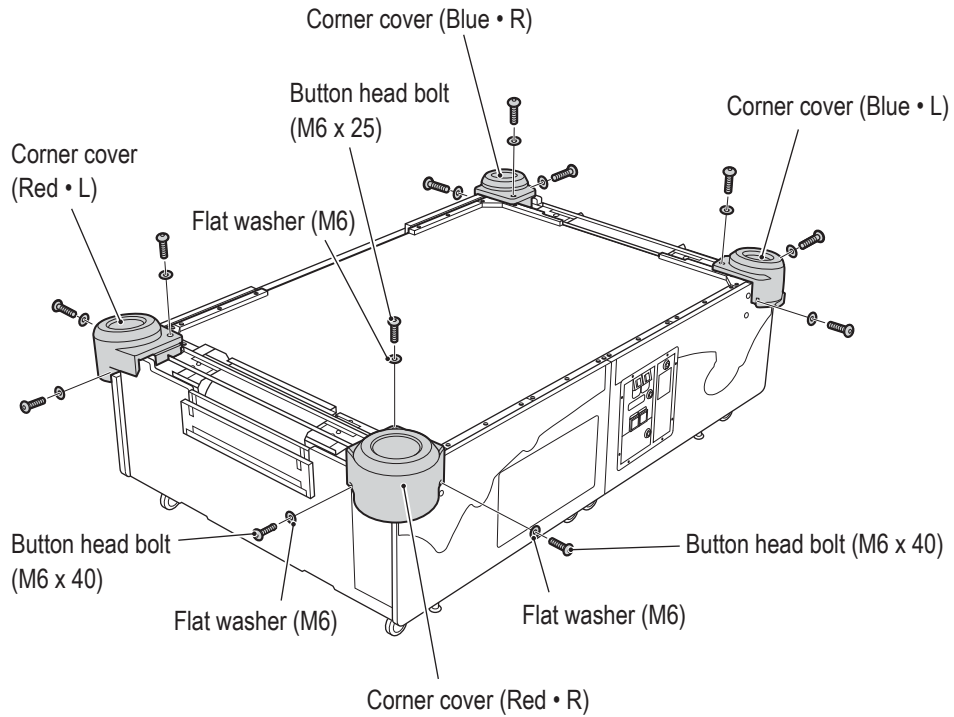

NOTICE

- If the bolts are difficult to tighten, loosen the screws fixing the goal bumper (L) • (R) and corner bumper, shift each bumper towards the outside of the table, and then tighten the screws.
- If any of the bumper fixing screws are loose, tighten the screws.
- When installing, be careful not to pinch the harnesses and connectors.

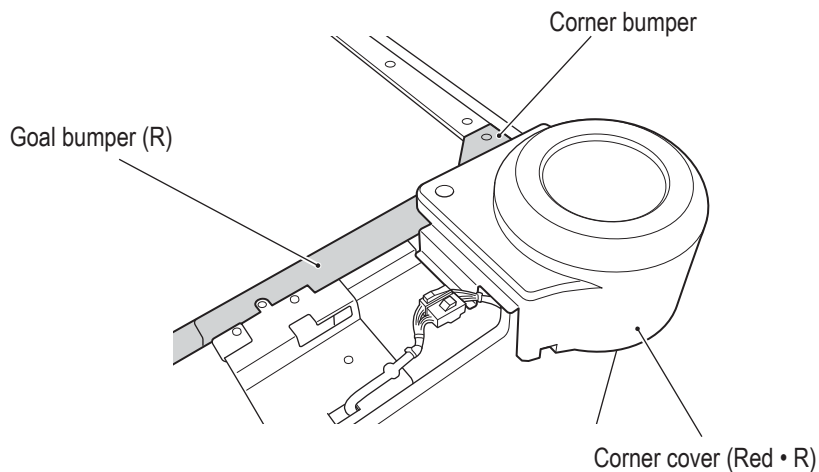

- 19** Tighten the bolts temporarily secured in steps **16** and **17**, and secure the goal (L) and (R) assemblies.
- 20** Close the goal (L) assembly. (See “7-5-3 Opening and Closing the Goal (L) and (R) Assemblies” on page 38.)



- Must be performed by a technician -

- 1
- 2
- 3
- 4
- 5
- 6
- 7
- 8A
- 8B
- 9
- 10
- 11
- 12

Assembly

21 Connect the connector, and place the goal cover (RED) on the goal (L) assembly.

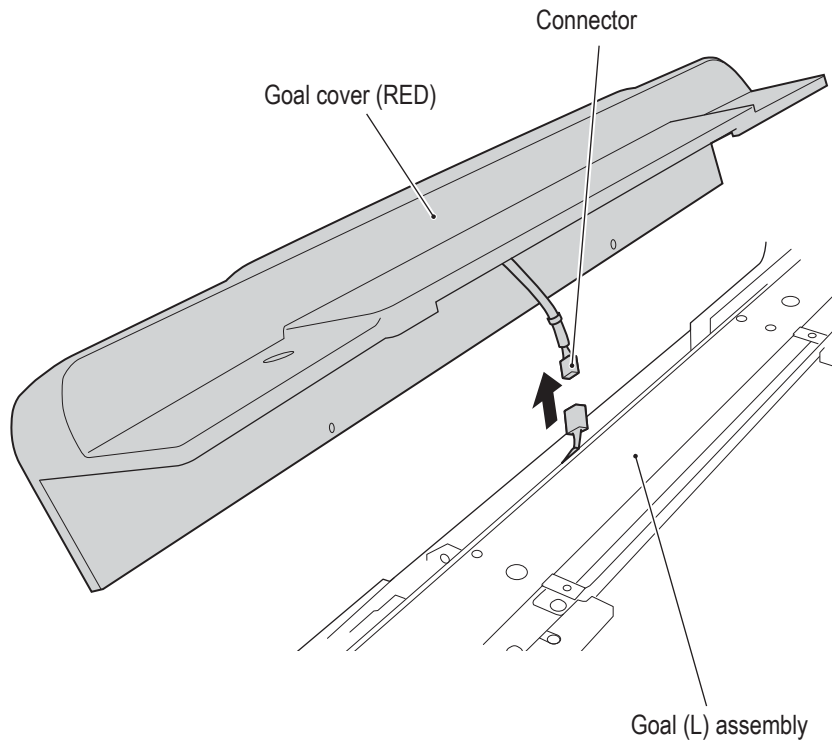

22 Attach the goal cover (RED) with two Torx bolts (M5 x 16) and two flat washers (M5), and with two Torx bolts (M5 x 20) and two flat washers (M5).



● When installing, be sure to use bolts of the specified length.

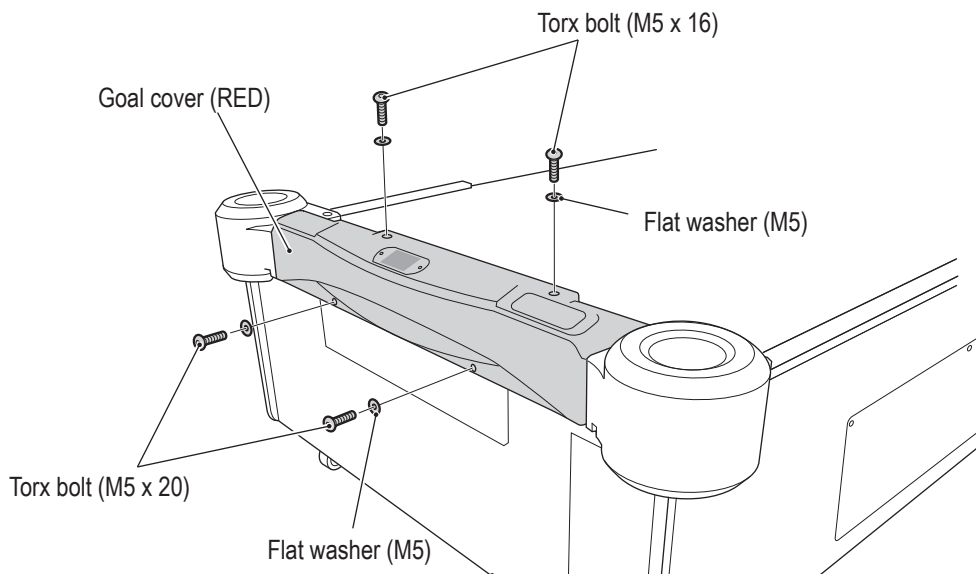

23 Open the goal (L) assembly. (See "7-5-3 Opening and Closing the Goal (L) and (R) Assemblies" on page 38.)

Test Mode

Troubleshooting

8A. Installation and Assembly

- Must be performed by a technician -

- 24** Secure the goal cover (RED) with two Torx bolts (M5 x 8).

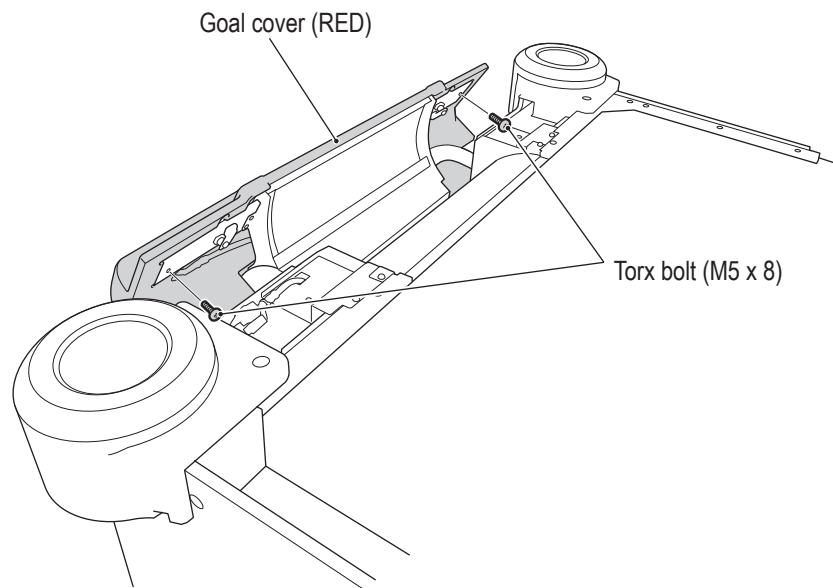

- 25** Follow the same procedure as steps **20** to **24** to install the goal (R) assembly and goal cover (BLUE).
- 26** Close the goal (L) and (R) assemblies. (See "7-5-3 Opening and Closing the Goal (L) and (R) Assemblies" on page 38.)



8A. Installation and Assembly

- Must be performed by a technician -

[If the goal (L) and (R) assembly locks are stiff, cannot be locked, or are loose, perform the procedure below.]

27 Remove the goal cover of the goal to be adjusted by reversing the procedure in steps **21** to **26**.

28 Loosen the four Phillips pan head screws (with flat and spring washers) (M4 x 10).

Phillips pan head screw (with flat and spring washers) (M4 x 10) (loosen)

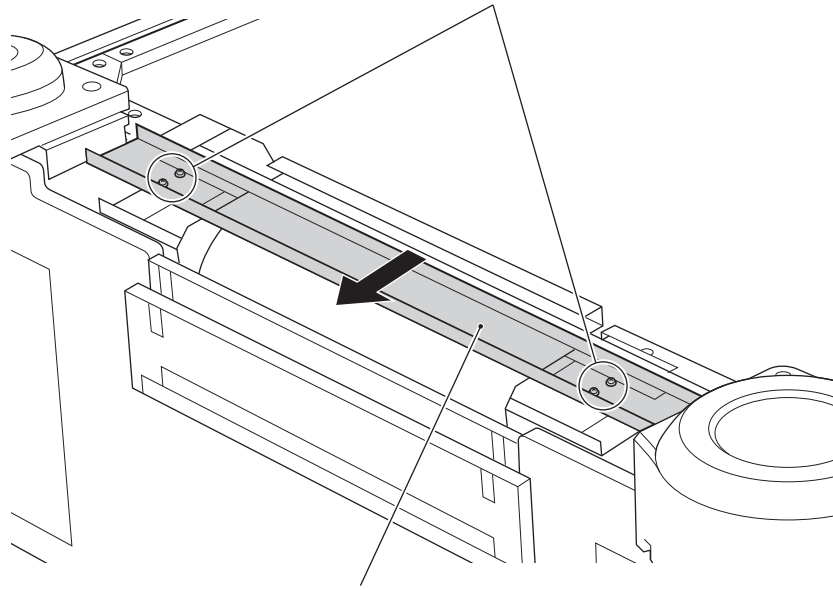

Goal outer beam

29 Shift the goal outer beam toward you until it stops, and then retighten the four Phillips pan head screws (with flat and spring washers) (M4 x 10) secure it.

*If the lock is stiff, shift the goal outer beam toward the back slightly before securing it.

30 Follow the procedure in steps **20** to **26** to reinstall the goal cover.

1

2

3

4

5

6

7

8A

8B

9

10

11

12

Assembly

Test Mode

Troubleshooting

8A. Installation and Assembly

- Must be performed by a technician -

(2) Installing the Nets

- 1** Attach the center guard bracket (A) with four button head bolts (M6 x 25) and four flat washers (M6).



- Install the center guard bracket (A) in a level manner so that it is not tilted.

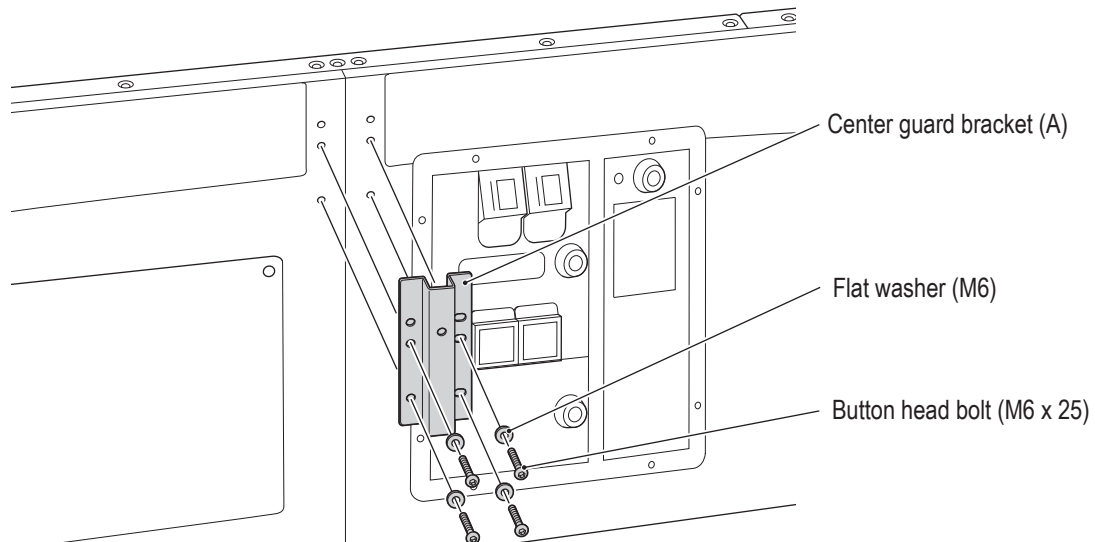

- 2** Attach the center guard bracket (B) with four button head bolts (M6 x 25) and four flat washers (M6).

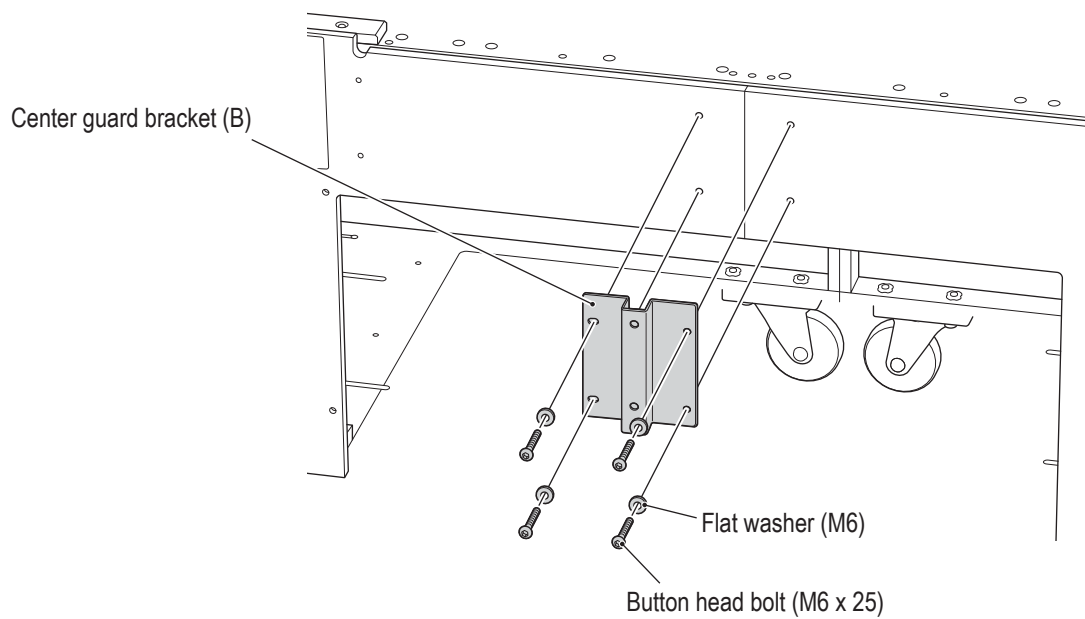



8A. Installation and Assembly

- Must be performed by a technician -

- 1
- 2
- 3
- 4
- 5
- 6
- 7
- 8A
- 8B
- 9
- 10
- 11
- 12

Assembly

- 3** Insert the center guard into the center guard brackets (A) and (B), and then secure it with three button head bolts (M6 x 16) and three flat washers (M6).
*Install the center guard so that the center guard retainer is facing the L side.

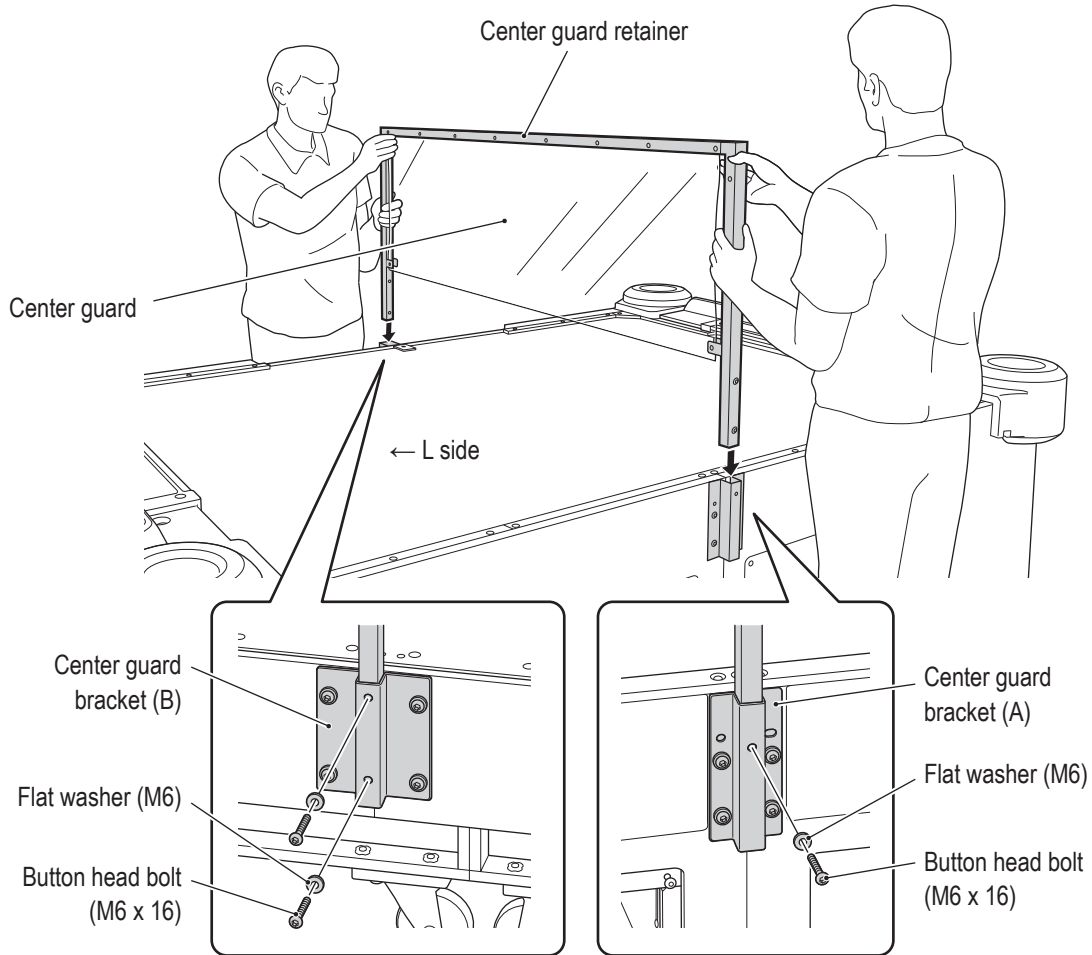

- 4** Insert the hooks of the net S frame (L) into the cabinet (L) assembly, and then secure it with four button head bolts (M6 x 50) and four flat washers (ø16 for M6).

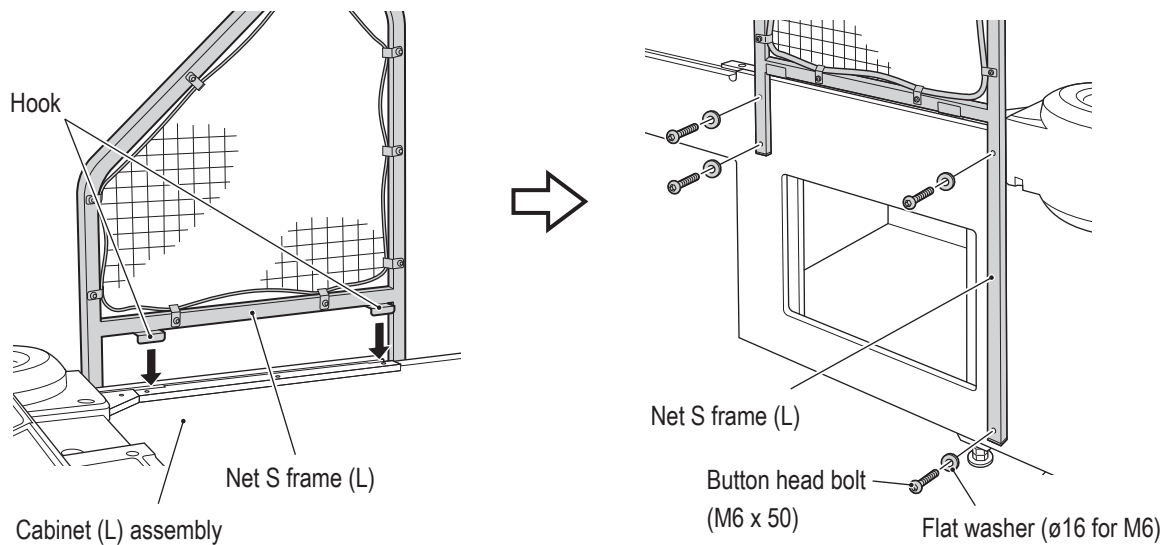

Test Mode

Troubleshooting



8A. Installation and Assembly

- Must be performed by a technician -

- 5** Follow the same procedure in step **4** to attach the net S frame (R) to the cabinet (R) assembly.
- 6** Insert the hooks of the net L frame (L) into the cabinet (L) assembly, and then secure it with three button head bolts (M6 x 50), three flat washers ($\varnothing 16$ for M6), and one flange socket bolt (M5 x 35).

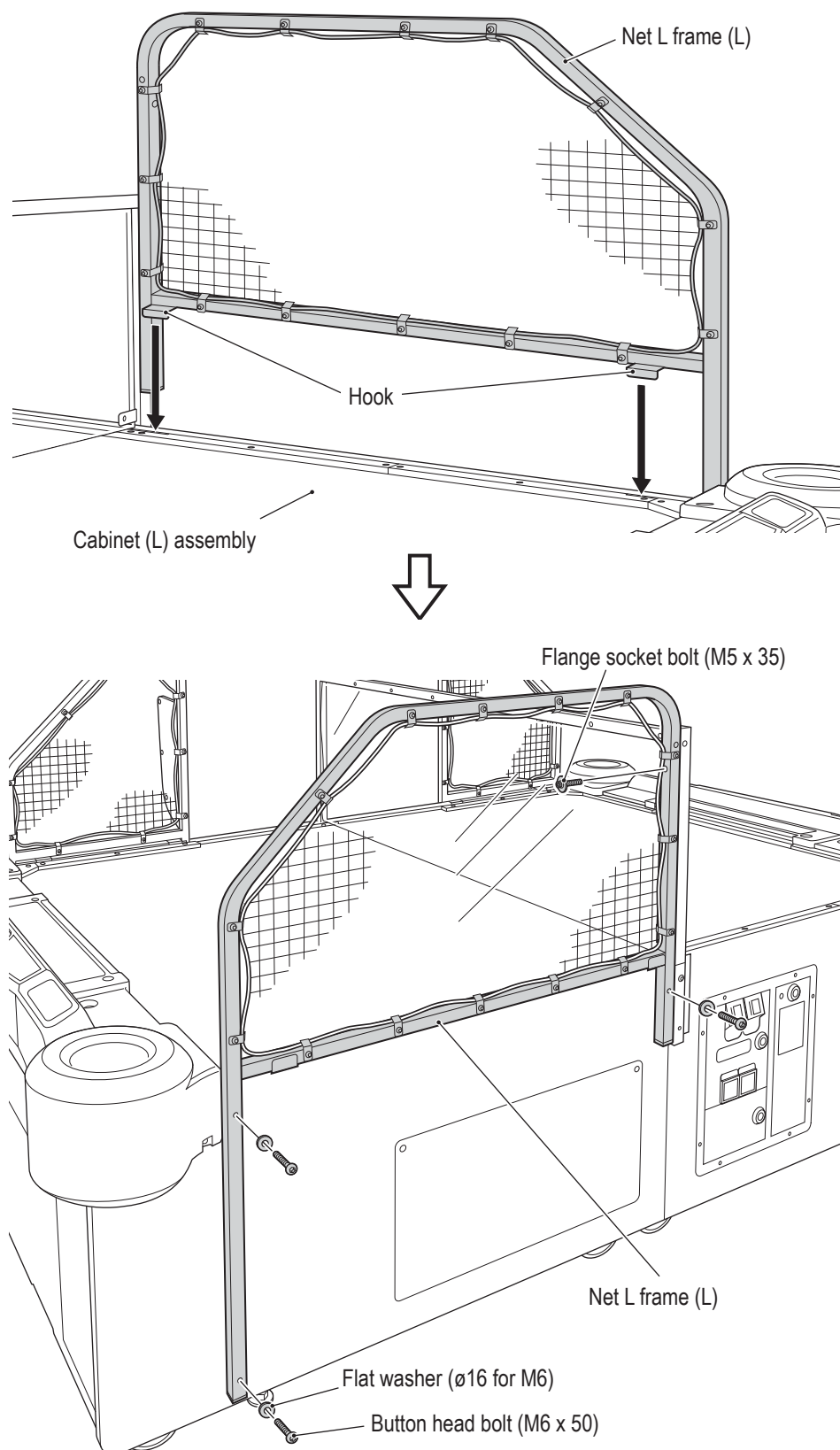



8A. Installation and Assembly

- Must be performed by a technician -

7 Follow the same procedure in step **6** to attach the net L frame (R) to the cabinet (R) assembly.

8 Attach the triangle bracket with five button head bolts (M5 x 16) and five flat washers (M5).

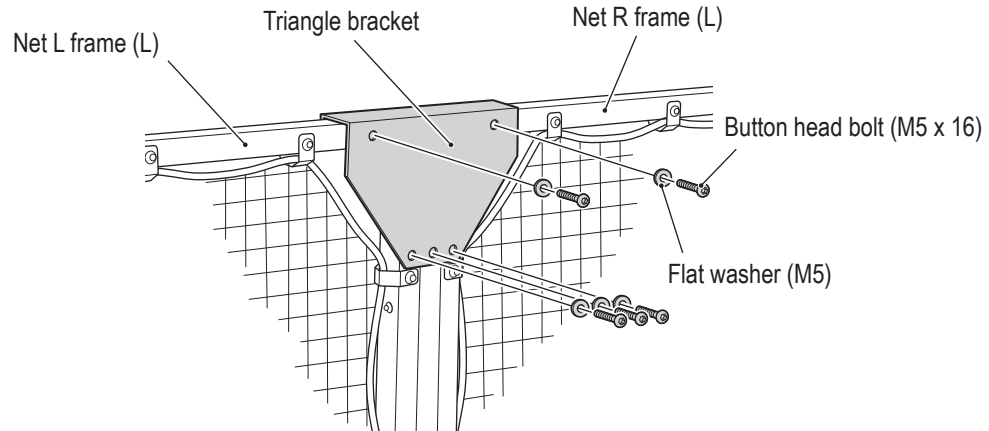

(3) Installing the Blower Fan

1 Remove the front door. (See "8A-5-1 Opening and Closing the Front Doors" on page 107.)

2 Insert the blower mounting plate into the blower brackets (L) and (R) from the goal (L) side, and secure it with four flange socket bolts (M5 x 30) and four flat washers (ø24 for M5).

3 Connect the connector.

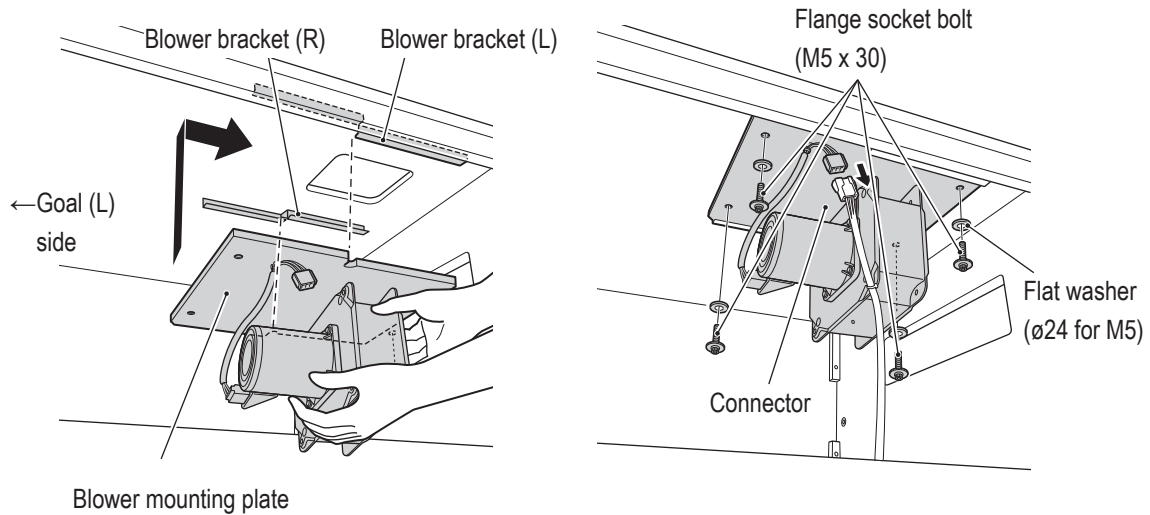

4 Reattach the front door. (See "8A-5-1 Opening and Closing the Front Doors" on page 107.)

1

2

3

4

5

6

7

8A

8B

9

10

11

12

Assembly

Test Mode

Troubleshooting

8A. Installation and Assembly

- Must be performed by a technician -

8A-2-2 Level Adjuster Adjustment

WARNING

- Adjust the level adjusters so that the table casters are at a height of approximately 5 mm from the floor. (The casters should be able to turn freely.) If the machine is unstable, it may move during game play.

NOTICE

- Adjust the level adjusters so that the table top surface is level. If the table top surface is tilted excessively, it may be difficult to collect the pucks and the machine may not function properly.

- 1** Install the table in accordance with “5-1 Installation Conditions” on page 24.
- 2** Adjust the level adjusters (four locations) so that the table casters are at a height of approximately 5 mm from the floor.
- 3** Secure the level adjusters with the lock nuts.

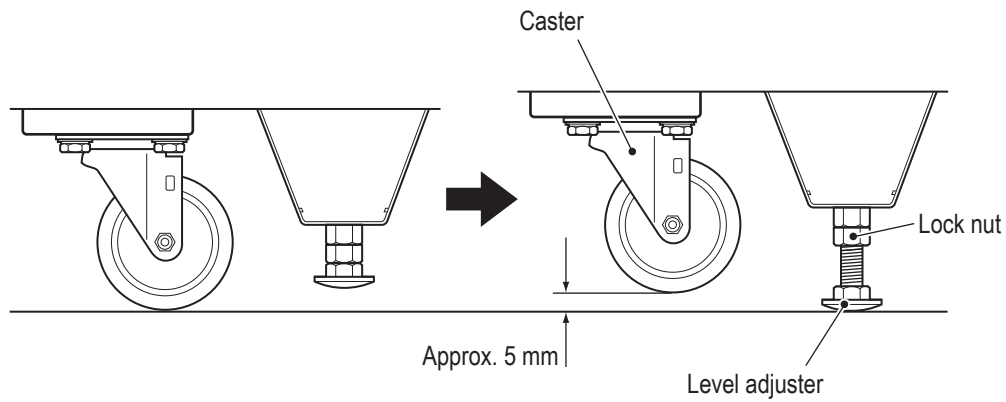



- Must be performed by a technician -

8A-2-3 Assembling the Side Tower Assembly

- 1** Attach the signboard with eight Torx bolts (M5 x 12).

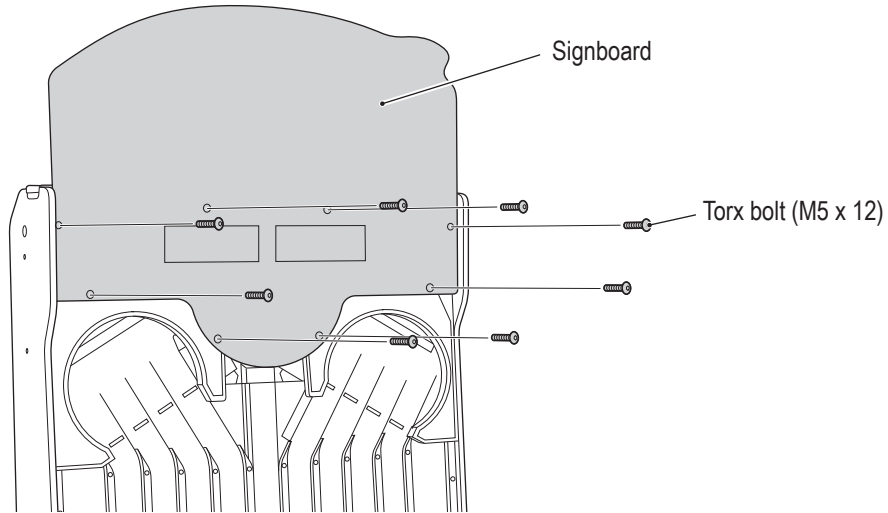

- 2** Remove the wing bolt (M4 x 6), slide the S bucket and S hopper cover toward the outside, and remove them.
- 3** Remove the wing bolt (M4 x 6), slide the L bucket and L hopper cover toward the outside, and remove them.

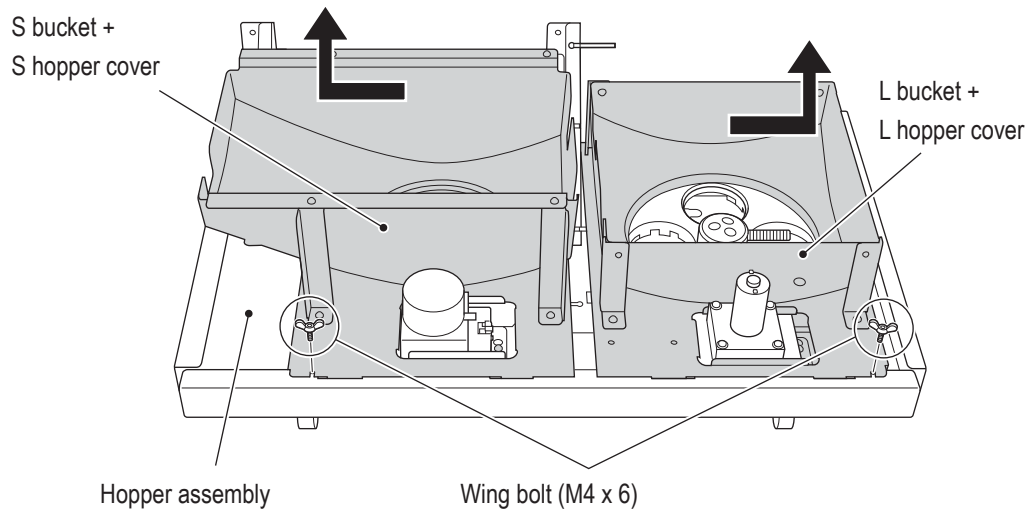

- 1
- 2
- 3
- 4
- 5
- 6
- 7
- 8A**
- 8B
- 9
- 10
- 11
- 12

Assembly

Test Mode

Troubleshooting

8A. Installation and Assembly

- Must be performed by a technician -

! WARNING

- Do not move the side tower cabinet in the condition with the caster brackets (F) removed. Doing so may cause the side tower cabinet to fall over.

- 4** Remove the four Phillips hexagon socket head bolts (with flat and spring washers) (M6 x 16), and remove the two caster brackets (F).

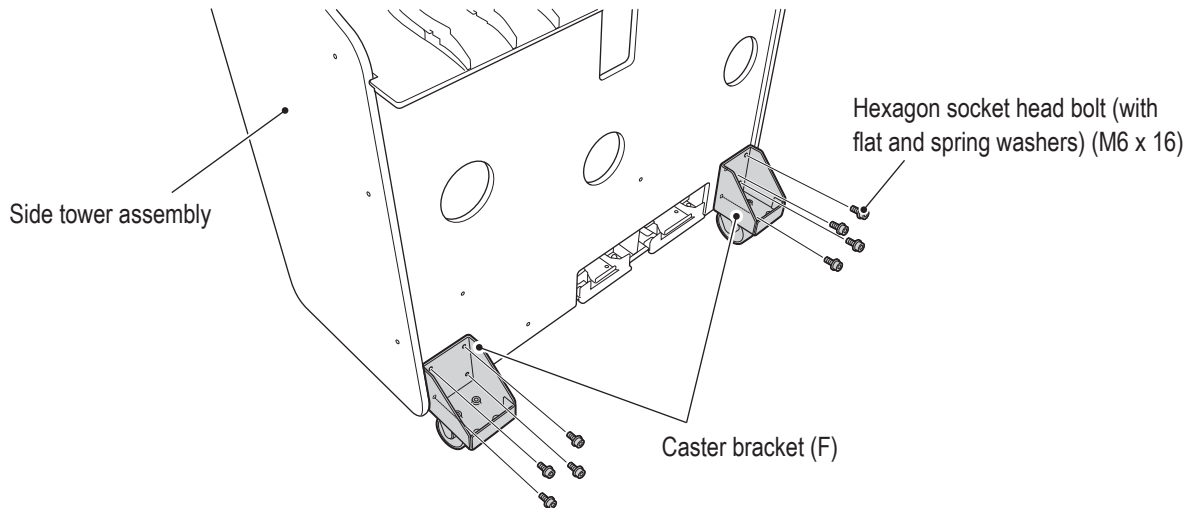

! NOTICE

- The removed caster brackets (F) and bolts are required during transport. Be sure to keep them in a safe place.

- 5** Attach the hopper assembly with four flange socket bolts (M6 x 20).

- 6** Connect the connector.

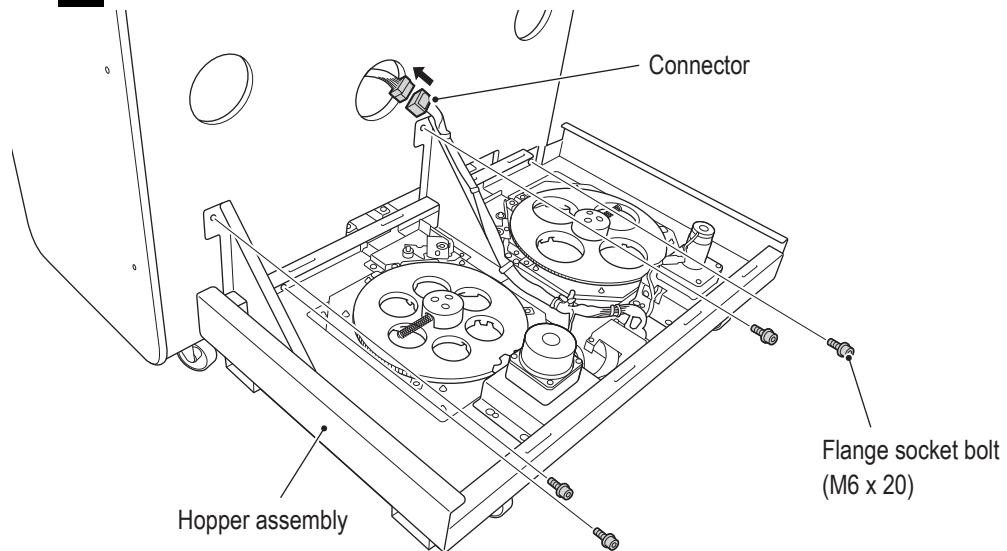

- 7** Reattach the L bucket and L hopper cover by reversing the procedure in step **3**.

- 8** Reattach the S bucket and S hopper cover by reversing the procedure in step **2**.



8A. Installation and Assembly

- Must be performed by a technician -

- 9** Attach the hopper wall with four Phillips pan head screws (with flat and spring washers) (M4 x 10).

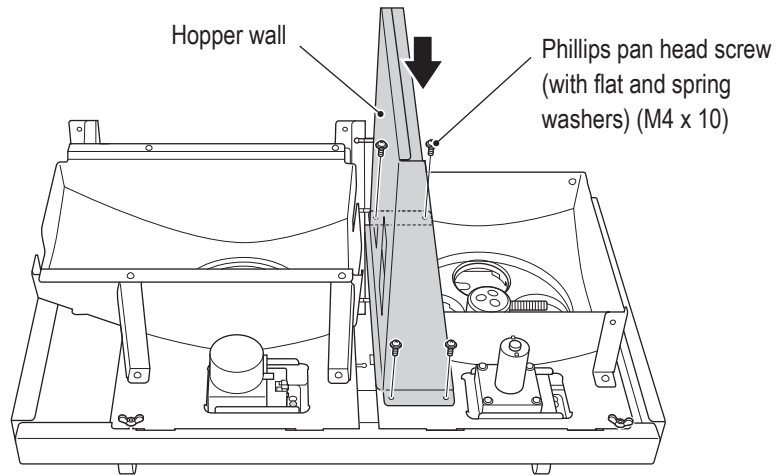

- 10** Remove the two Phillips pan head screws (with flat and spring washers) (M4 x 10), and remove the hopper wall B. Reverse the direction of the removed hopper wall B, and then reattach it with the removed screws.

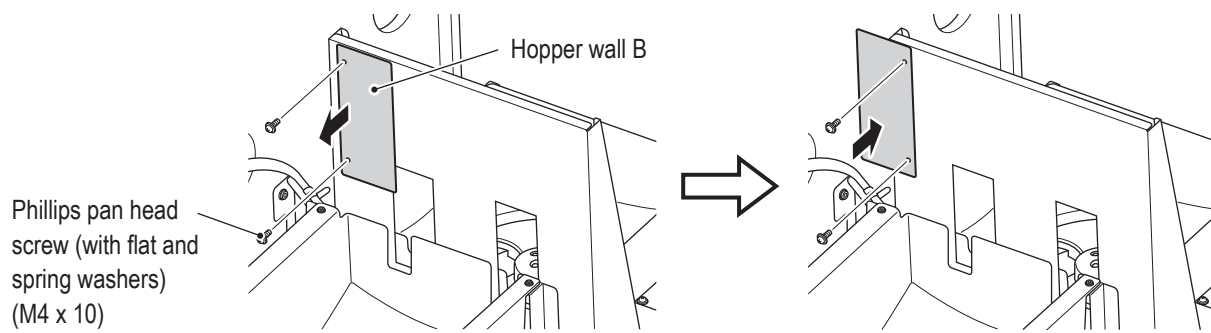

1

2

3

4

5

6

7

8A

8B

9

10

11

12

Assembly

Test Mode

Troubleshooting

8A. Installation and Assembly

- Must be performed by a technician -

8A-2-4 Installing the Light Assembly

WARNING

- The light assembly is installed while standing in a high location. Use a stool or similar platform. Working in an unnatural body posture may cause an injury or machine damage.

- 1** Lead the connector extending from the light arm L through the hole in the side tower assembly and into the machine.
- 2** Attach the light arm L with two button head bolts (M6 x 50) and two flat washers (ø7 x ø24).

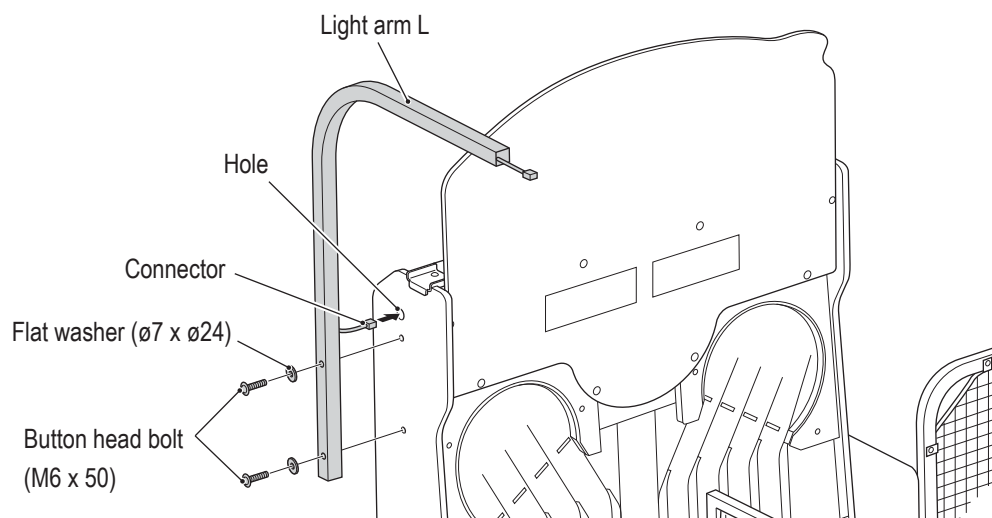

- 3** Follow the same procedure to install the light arm R.
- 4** Insert the light arms L and R into the light frame unit, and attach them with flange socket bolts (M6 x 16).

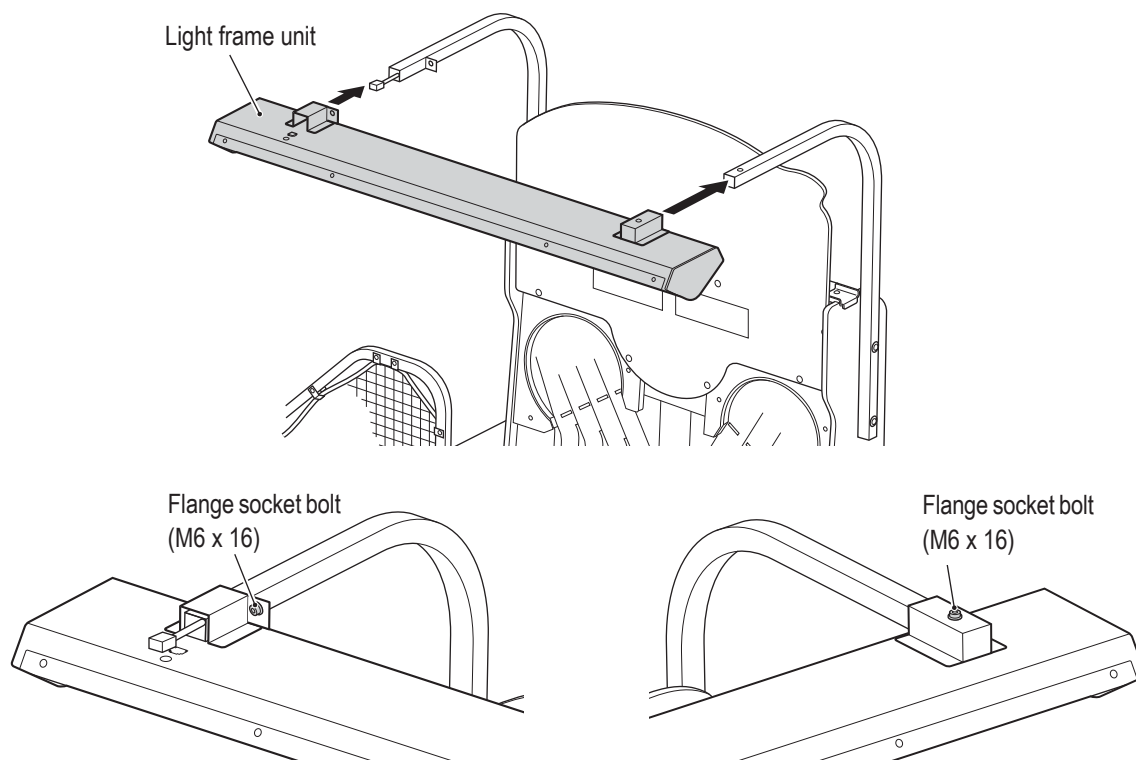



8A. Installation and Assembly

- Must be performed by a technician -

- 5** Connect the connectors.
- 6** Attach the connector cover with a Phillips pan head screw (with flat and spring washers) (M4 x 10).

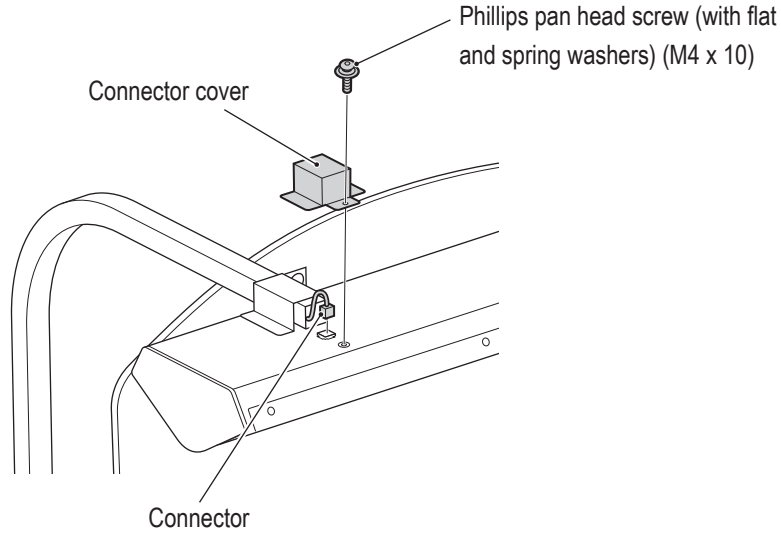

- 7** Remove the rear panel. (See "8A-5-3 Opening and Closing the Rear Panel" on page 108.)
- 8** Connect the connector.

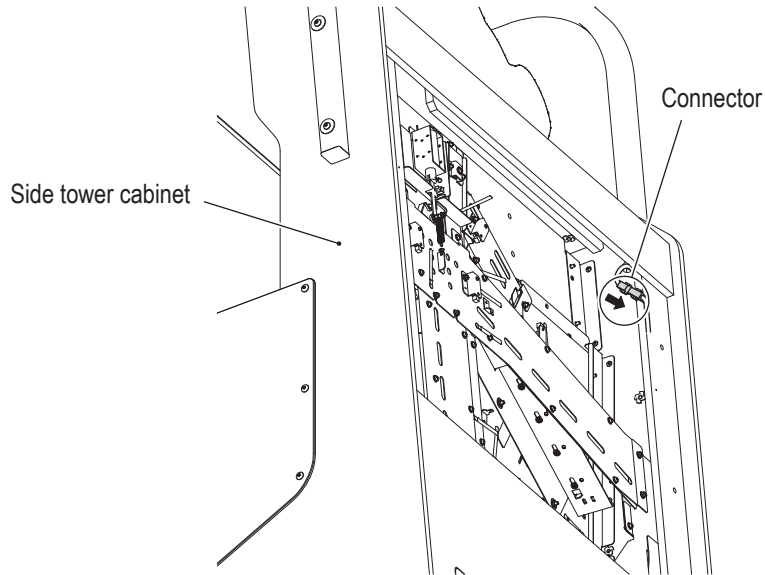

- 9** Install the rear panel. (See "8A-5-3 Opening and Closing the Rear Panel" on page 108.)

- 1
- 2
- 3
- 4
- 5
- 6
- 7
- 8A**
- 8B
- 9
- 10
- 11
- 12

Assembly

Test Mode

Troubleshooting

8A. Installation and Assembly

- Must be performed by a technician -

8A-2-5 Installing the Side Tower Assembly

- 1** Lead out the five connectors from the right and left holes in the front of the side tower cabinet.

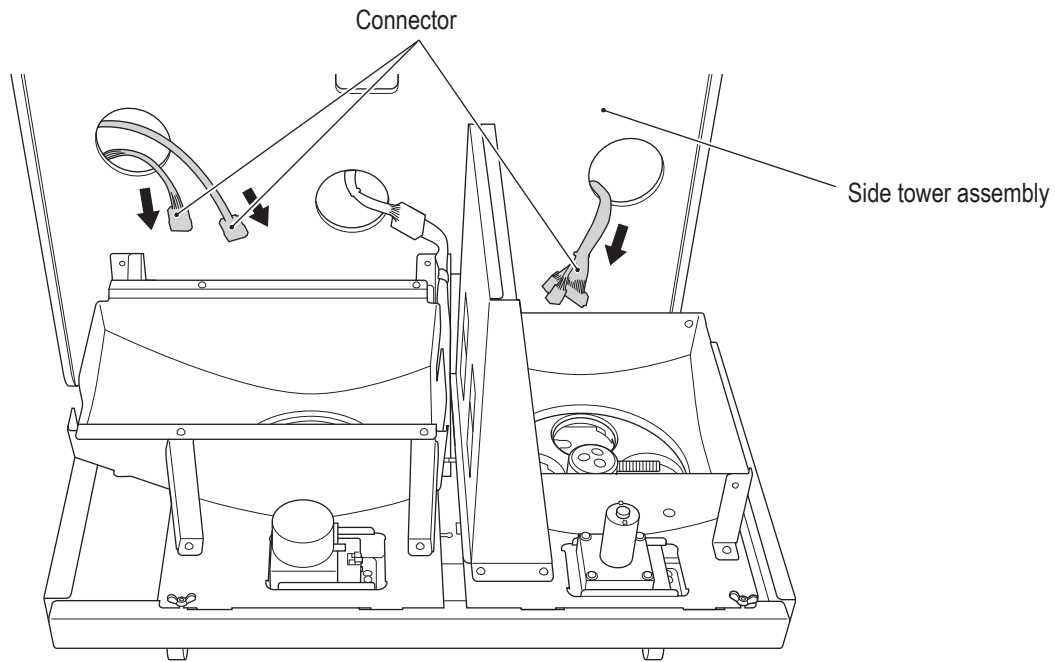

- 2** Remove the Torx bolt (M5 x 25).

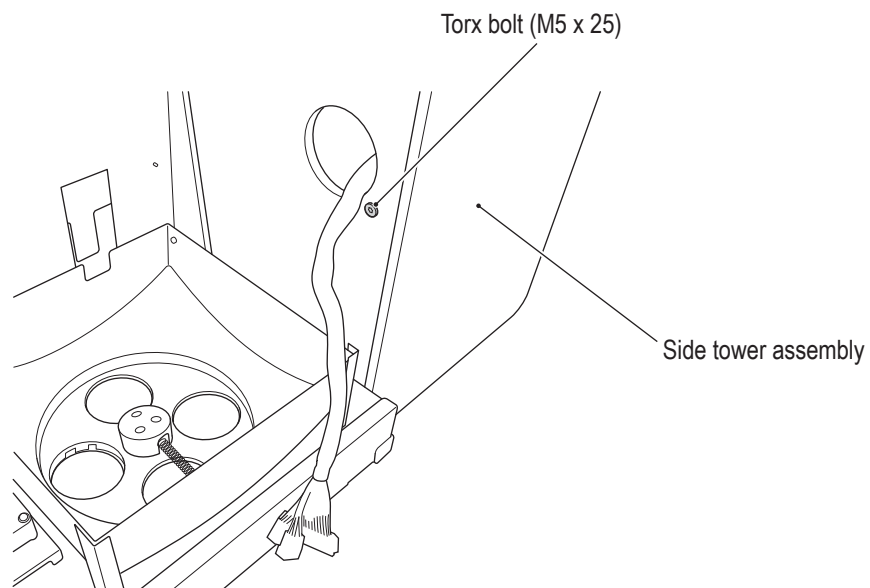



8A. Installation and Assembly

- Must be performed by a technician -

- 3** Secure the harness clamp of the harness led out in step **1** with the Torx bolt (M5 x 25) removed in step **2**.

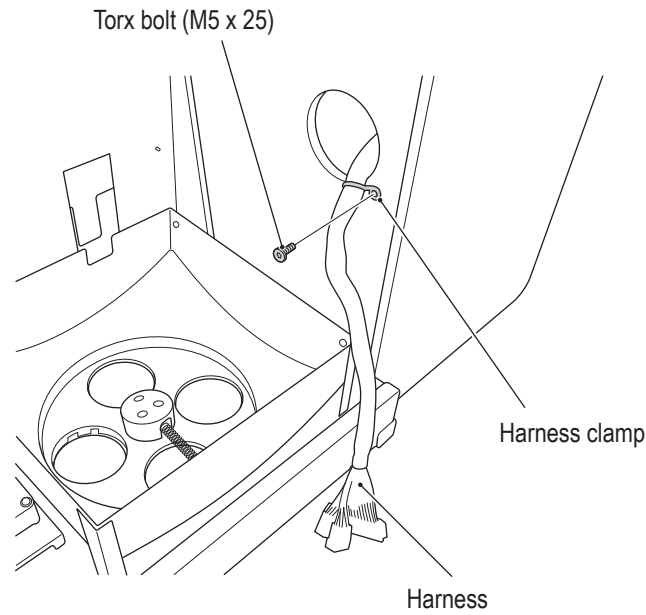

- 4** Attach the side tower bracket (L) and side tower bracket (R) with two flange socket bolts (M6 x 20) each.

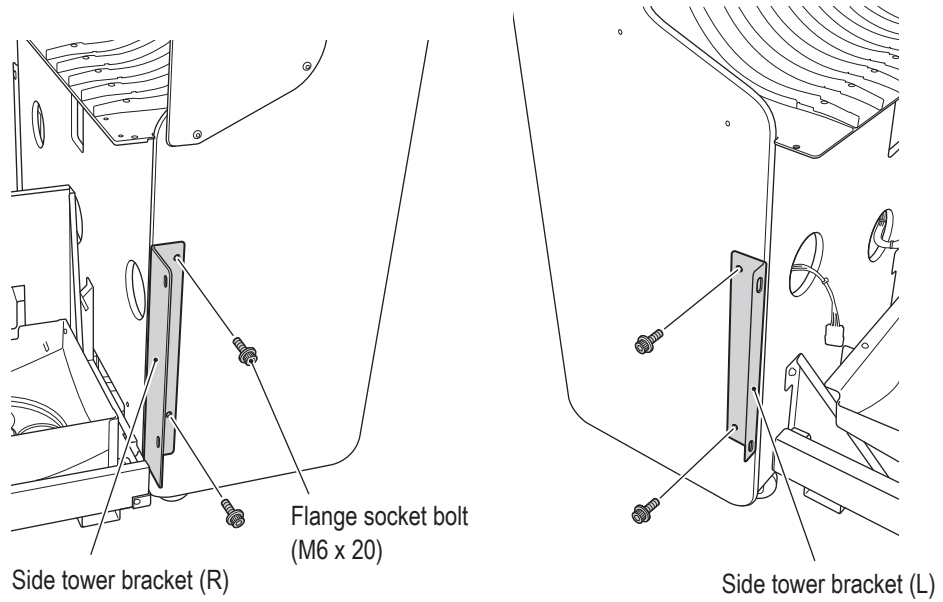

1

2

3

4

5

6

7

8A

8B

9

10

11

12

Assembly

Test Mode

Troubleshooting

8A. Installation and Assembly

- Must be performed by a technician -

- 5** While lifting up the sloped area of the side tower assembly, insert the hopper assembly into the opening in the side surface of the table until the front of the side tower assembly touches the side surface of the table.

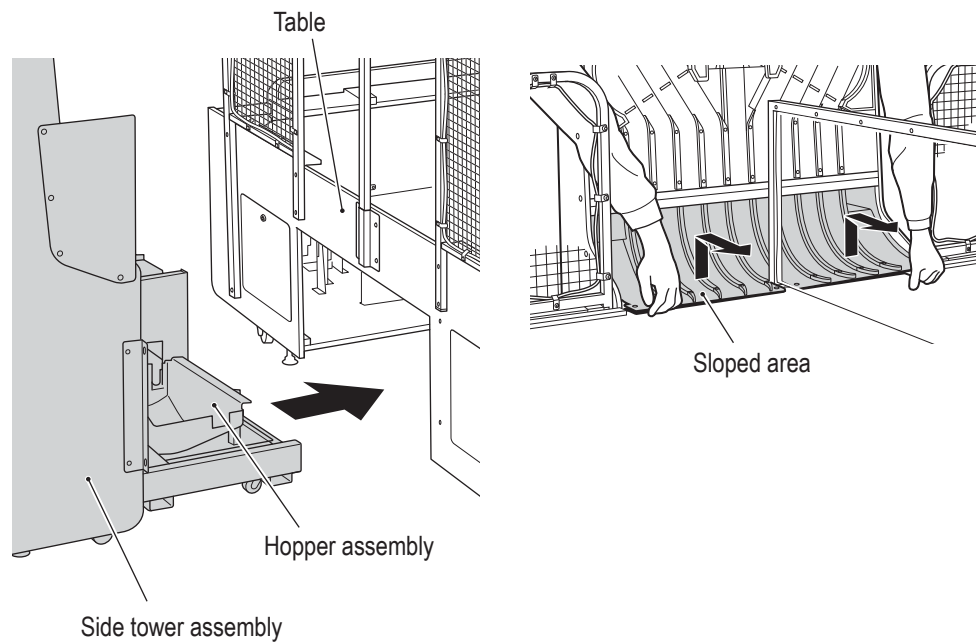

- 6** Attach the side tower assembly to the table with four flange socket bolts (M6 x 20).

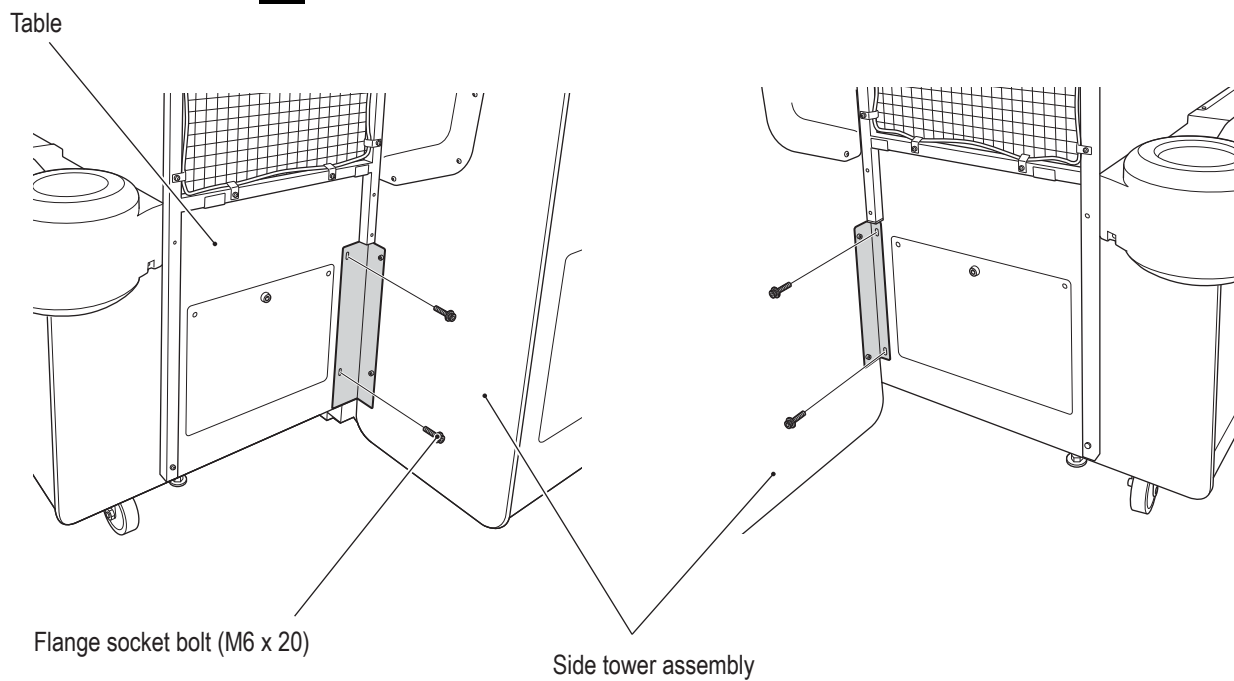



- Must be performed by a technician -

- 1
- 2
- 3
- 4
- 5
- 6
- 7
- 8A
- 8B
- 9
- 10
- 11
- 12

Assembly

- 7** Attach the side tower assembly with 2 countersunk cap bolts (M5 x 35), 4 button head bolts (M5 x 35).

[If the bolt holes are not aligned during procedure, go to step **20**.]

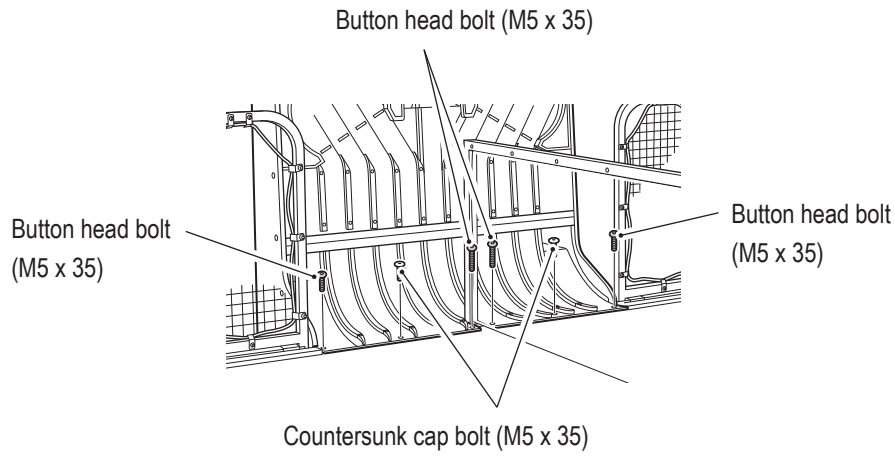

- 8** Remove the service door L. (See "8A-5-2 Opening and Closing the Service Doors L and R" on page 107.)

- 9** Connect the two connectors inside the cabinet (L) assembly.

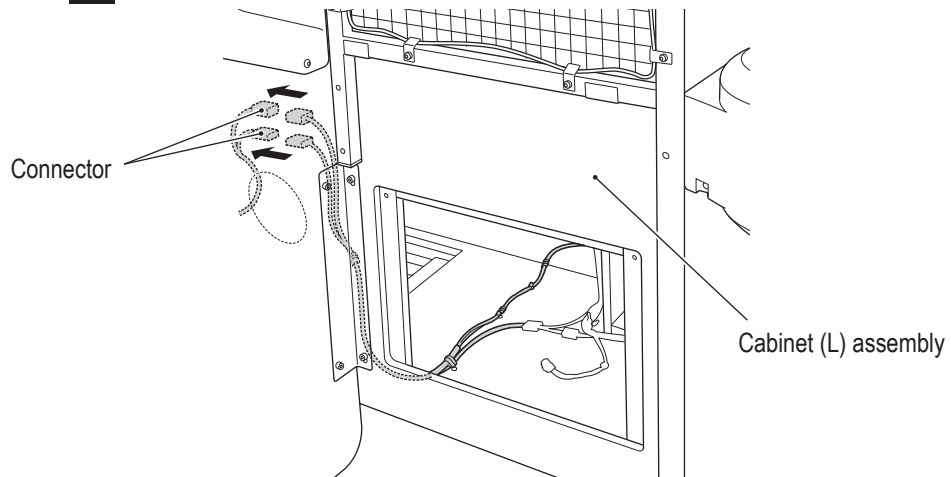

Test Mode

Troubleshooting

8A. Installation and Assembly

- Must be performed by a technician -

- 10** Insert the tip of the rail (L) assembly into the square hole in the back side of the hopper assembly, and hook the hook on the opposite side of the rail (L) assembly onto the corner rail (L).



- Attach the rail so that the plate below the hook is on the outside of the rail.

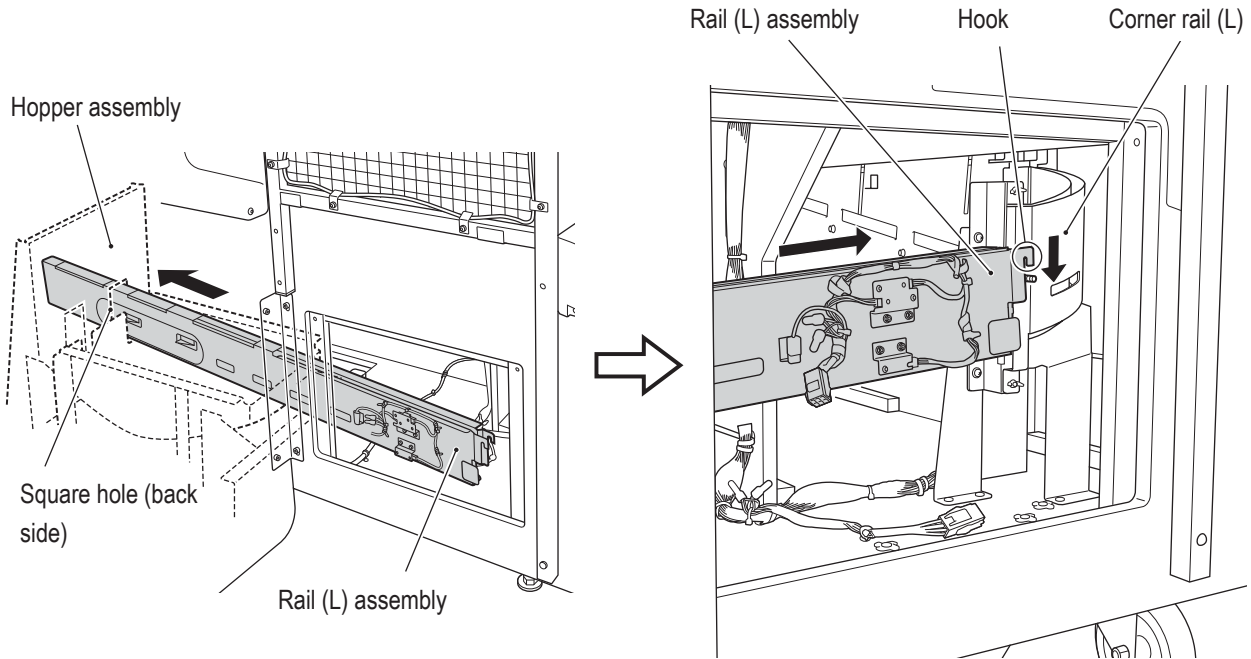

- 11** Connect the connector.

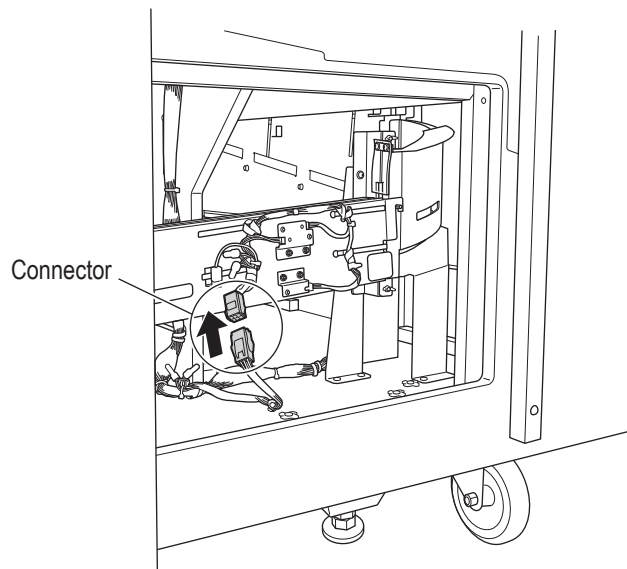

- 12** Reattach the service door L. (See "8A-5-2 Opening and Closing the Service Doors L and R" on page 107.)



8A. Installation and Assembly

- Must be performed by a technician -

13 Remove the service door R. (See "8A-5-2 Opening and Closing the Service Doors L and R" on page 107.)

14 Connect the three connectors inside the cabinet (R) assembly.

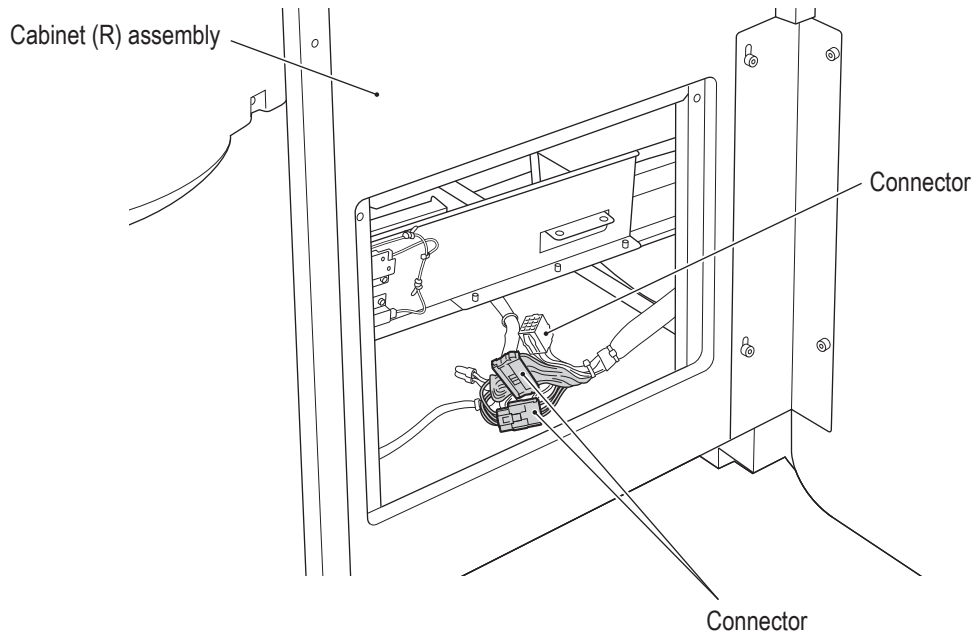

15 Insert the tip of the rail (R) assembly into the square hole in the front side of the hopper assembly, and hook the hook on the opposite side of the rail (R) assembly onto the corner rail (R).

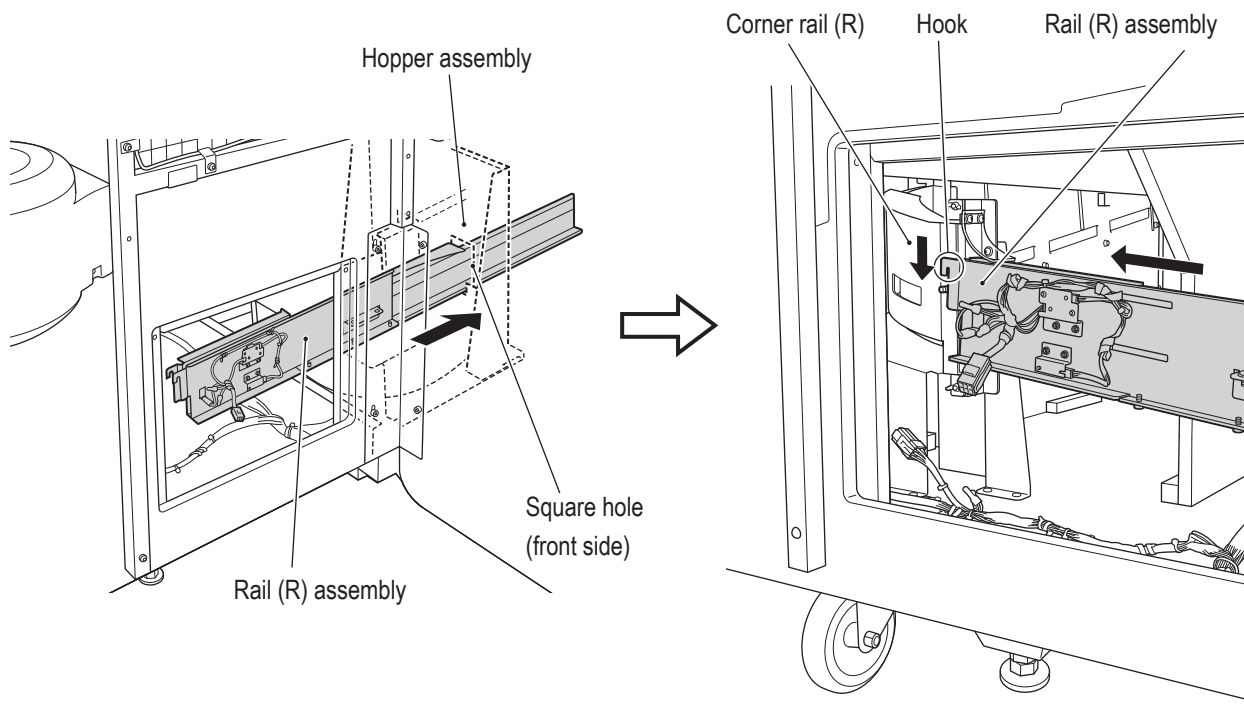

- 1
- 2
- 3
- 4
- 5
- 6
- 7
- 8A**
- 8B
- 9
- 10
- 11
- 12

Assembly

Test Mode

Troubleshooting

8A. Installation and Assembly

- Must be performed by a technician -

- 16** Connect the connector.

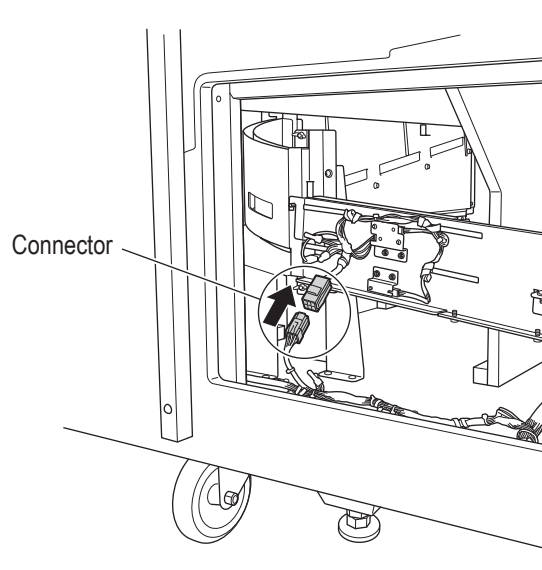

- 17** Reattach the service door R. (See "8A-5-2 Opening and Closing the Service Doors L and R" on page 107.)

- 18** Attach the two side walls with four Torx bolts (M5 x 16) each.

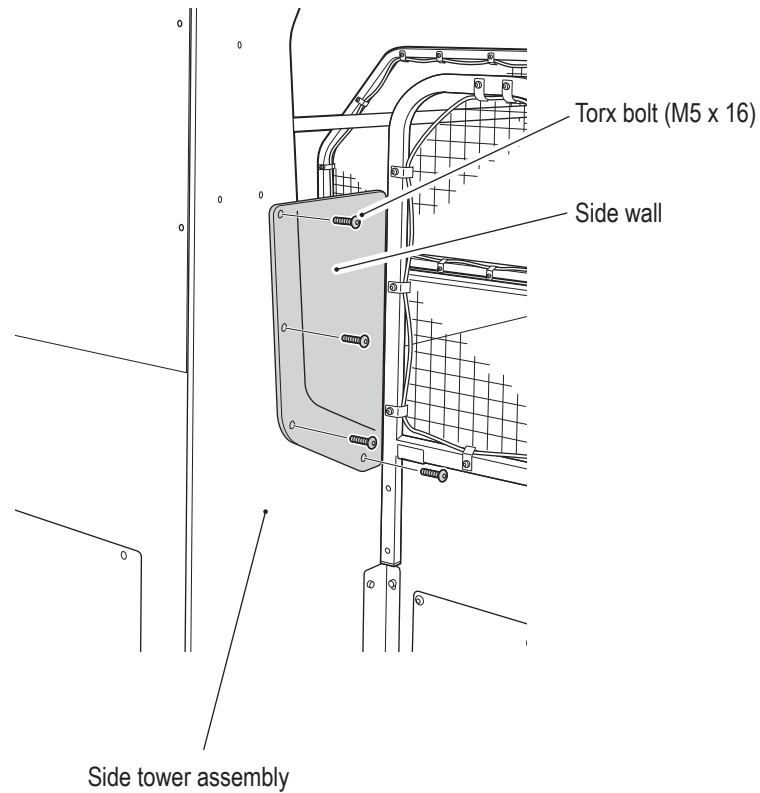



- Must be performed by a technician -

- 1
- 2
- 3
- 4
- 5
- 6
- 7
- 8A**
- 8B
- 9
- 10
- 11
- 12

Assembly

- 19** Remove the four Phillips hexagon socket head bolts (with flat and spring washers) (M6 x 16), and remove the two caster brackets (R).

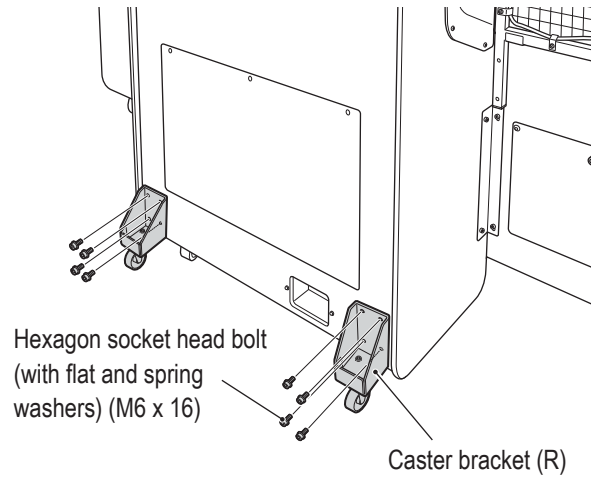

- The removed caster brackets (R) and bolts are required during transport. Be sure to keep them in a safe place.

[This completes the assembly work. Go to "8A-2-6 Preparing the Pucks and Mallets". If the bolt holes were not aligned in step 7, perform the procedure below.]

- 20** Remove the rear panel. (See "8A-5-3 Opening and Closing the Rear Panel" on page 108.)
- 21** Loosen the four Phillips pan head screws (with flat and spring washers) (M4 x 10).
- 22** Loosen the four Phillips pan head screws (with flat and spring washers) (M4 x 35), and adjust so that the sloped area matches the height of the playing field.

Phillips pan head screw (with flat and spring washers) (M4 x 35) (loosen)

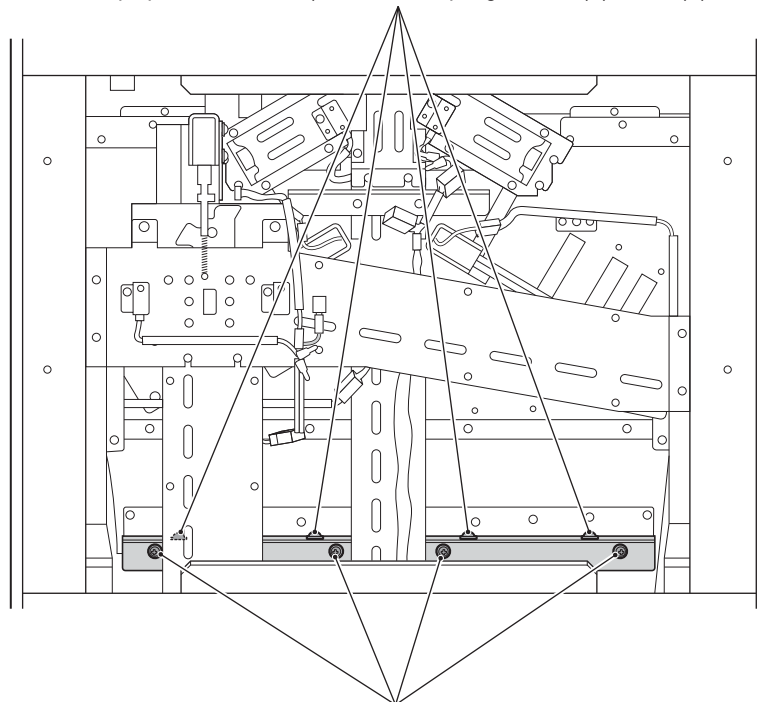

Phillips pan head screw (with flat and spring washers) (M4 x 10) (loosen)

Test Mode

Troubleshooting

8A. Installation and Assembly

- Must be performed by a technician -

- 23** Attach the side tower assembly with 2 countersunk cap bolts (M5 x 35), 4 button head bolts (M5 x 35).

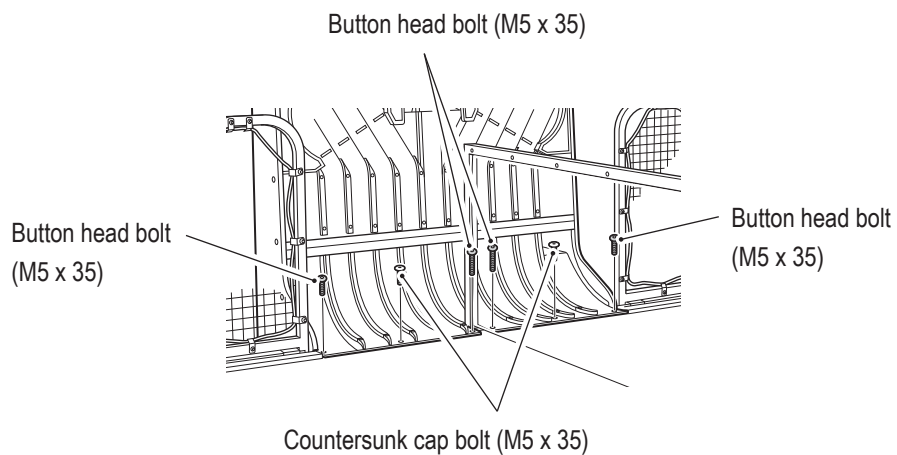

- 24** Tighten the four Phillips pan head screws (with flat and spring washers) (M4 x 35).
- 25** Tighten the four Phillips pan head screws (with flat and spring washers) (M4 x 10).

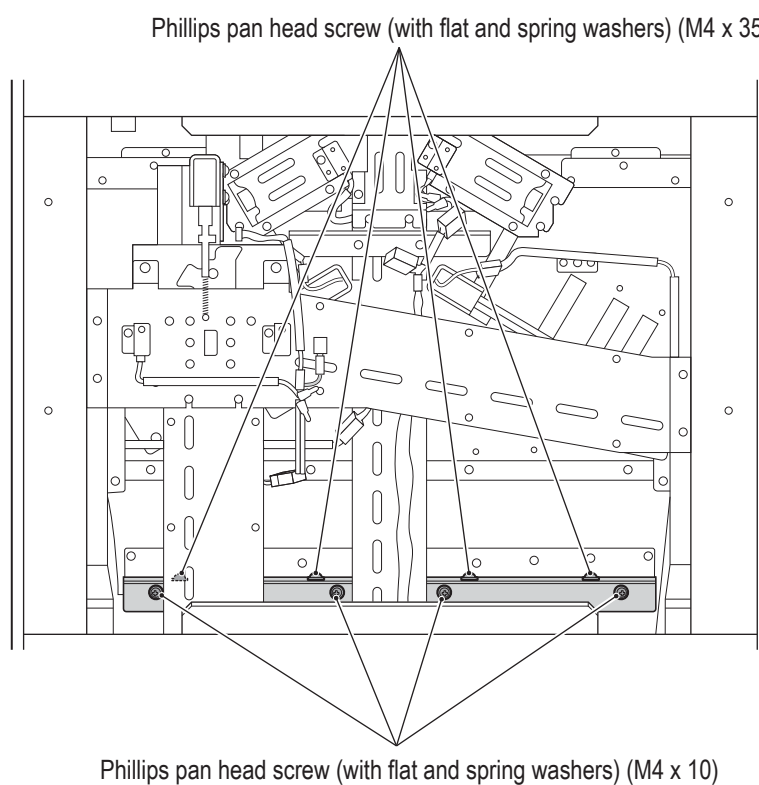

- 26** Reattach the rear panel. (See "8A-5-3 Opening and Closing the Rear Panel" on page 108.)
- 27** Go to step **8**.



- Must be performed by a technician -

8A-2-6 Preparing the Pucks and Mallets

1 Place the mallets on the corner covers.

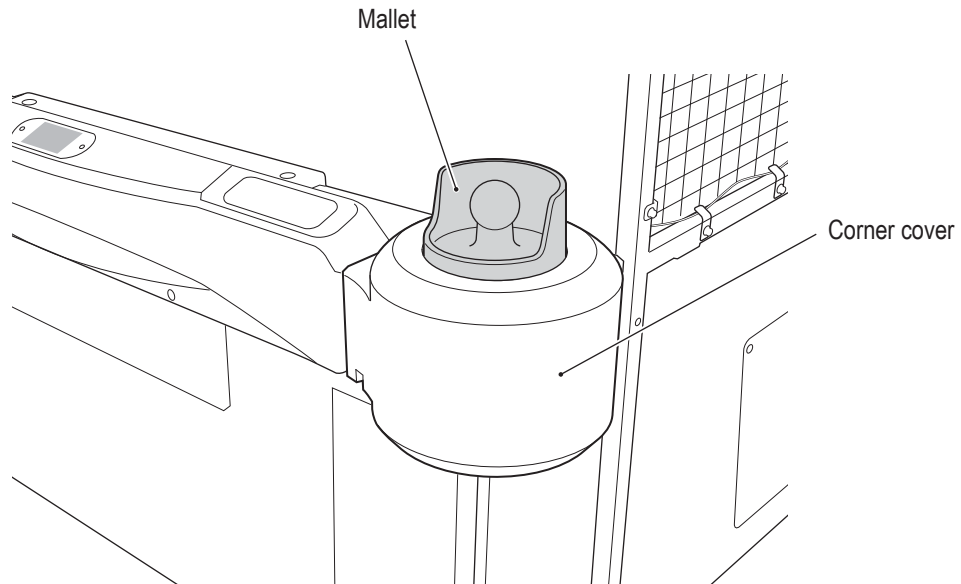

2 Put 50 of each of the big pucks and mini pucks (green, pink, orange) into the goal (L).

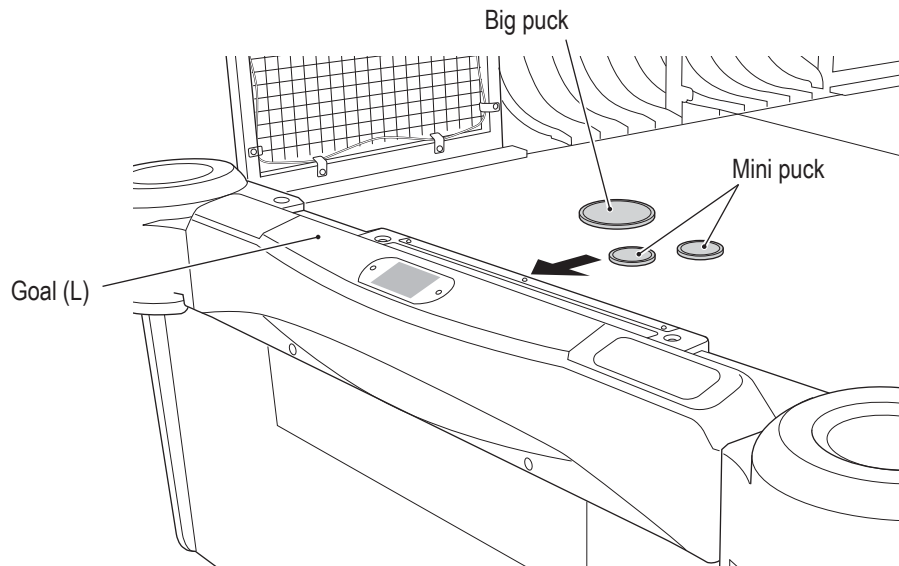

- Put the pucks into the goal (L) one to three pucks at a time. If many pucks are put into the goal at once, the pucks may become jammed inside the machine and prevent normal operation.
- Be sure to put the pucks into the goal (L) side.
- Do not put 60 or more big pucks or a total of 160 or more mini pucks of any color into the machine. Doing so may cause a malfunction.

- 1
- 2
- 3
- 4
- 5
- 6
- 7
- 8A**
- 8B
- 9
- 10
- 11
- 12

Assembly

Test Mode

Troubleshooting

8A. Installation and Assembly

- Must be performed by a technician -

8A-3 Connecting the Power Cord and Ground

⚠ WARNING

- Be sure to install the ground wire. Failure to install the ground wire may result in electric shock in the event of electrical leakage.

- 1** Insert the socket side of the power cord into the power supply input socket of the cordbox assembly.

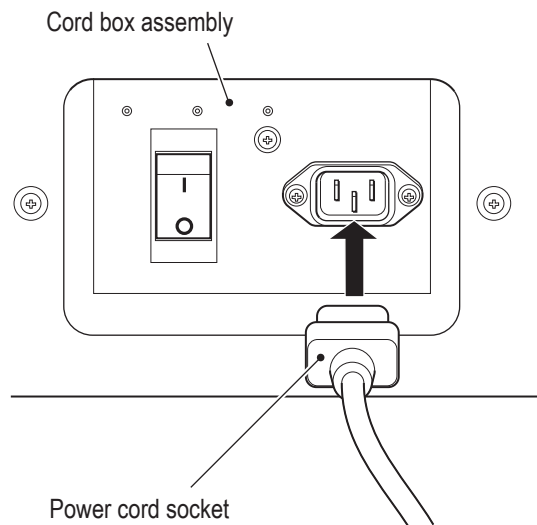

- 2** Insert the power cord plug into an outlet.

8A-4 Checks after Installation

After installation is complete, test each item in the Test mode, and set the necessary items in the Setting mode. (See "7-8 Test Mode" on page 41 and "7-9 Setting Mode" on page 51.)

NOTICE

- After installation is complete, be sure to perform the puck supply operation to add pucks into the machine. (See "L Hopper Motor ON/OFF Test and Sensor Check" on page 47 and "7-8-7 S Hopper Motor ON/OFF Test and Sensor Check" on page 48.)
- After adding mini pucks into the machine, check that there are ten mini pucks in each of the right and left sides of the mini puck stock area, and then be sure to reset the mini puck decrease count. (See "7-9-9 Mini puck low warning ON/OFF" on page 60.)



- Must be performed by a technician -

8A-5 Opening and Closing Doors

8A-5-1 Opening and Closing the Front Doors

- 1 Remove the two Torx bolts (M5 x 35), and remove the front door on the side to be opened.

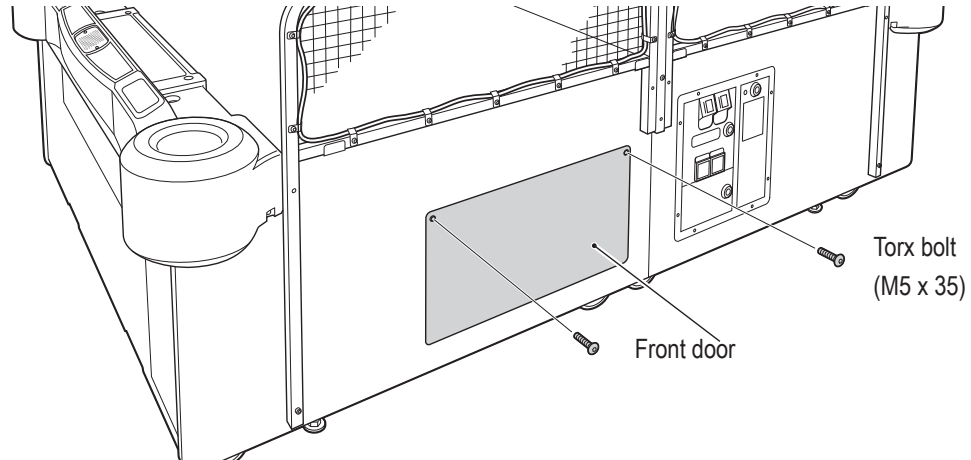

- 2 To install, perform the procedure in reverse.

8A-5-2 Opening and Closing the Service Doors L and R

- 1 Remove the two Torx bolts (M5 x 35).
- 2 Use the supplied service key to unlock, and remove the service door L or service door R.

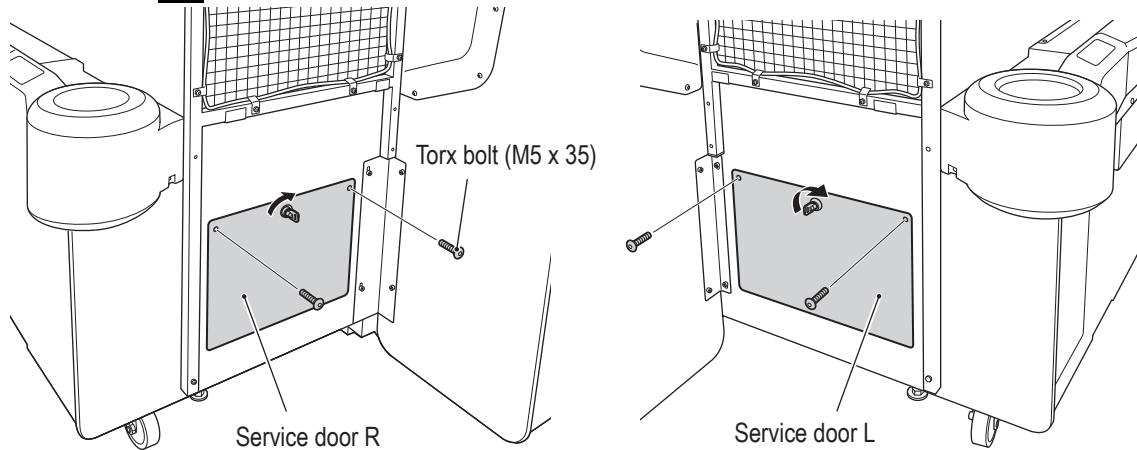

- 3 To install, perform the procedure in reverse.

- 1
- 2
- 3
- 4
- 5
- 6
- 7
- 8A
- 8B
- 9
- 10
- 11
- 12

Connecting the Power Cord and Ground / Checks after Installation / Opening and Closing Doors

Test Mode

Troubleshooting

8A. Installation and Assembly

- Must be performed by a technician -

8A-5-3 Opening and Closing the Rear Panel

- 1** Remove the four Torx bolts (M5 x 25).
- 2** Use the supplied service key to unlock, and remove the rear panel.

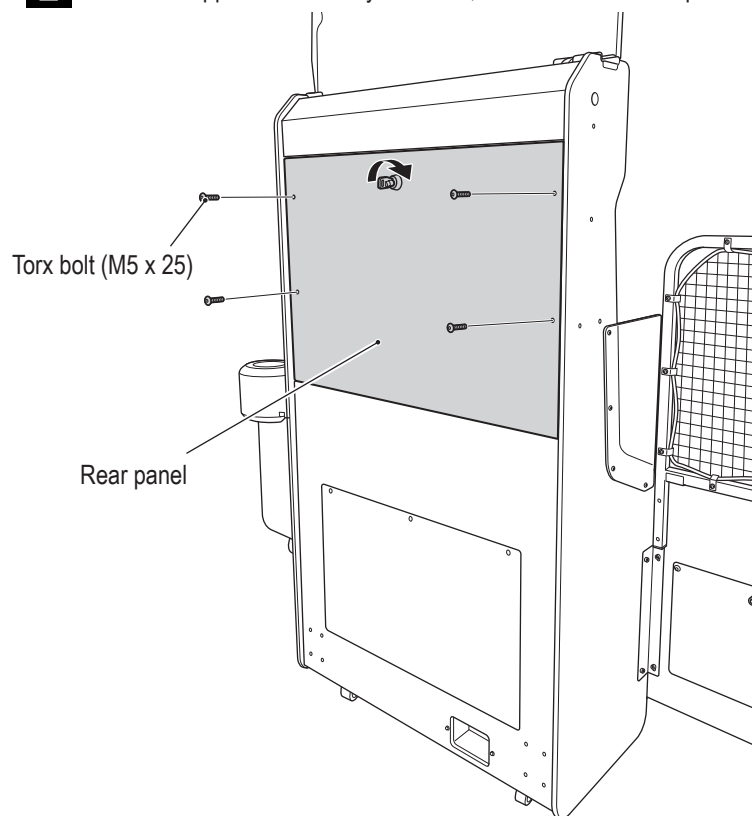

- 3** To install, perform the procedure in reverse.

8A-5-4 Opening and Closing the Service Door

- 1** Remove the three Torx bolts (M5 x 25), and remove the service door.

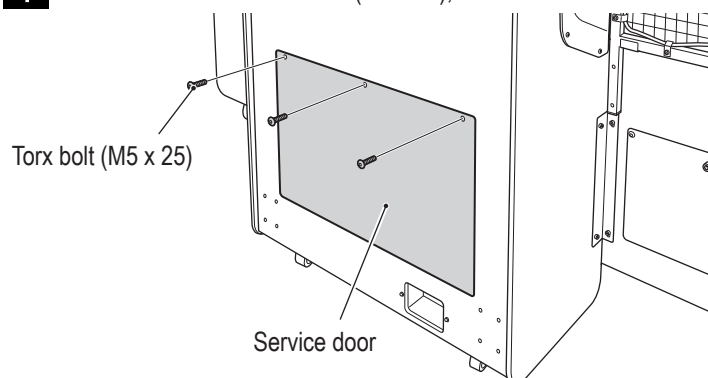

- 2** To install, perform the procedure in reverse.



- Must be performed by a technician -

8B. Service - Must be performed by a technician -

WARNING

- To avoid electric shock, accidents or injuries to yourself or other people, or damage to the electronic circuits, be sure to turn off the power switch before performing service work (such as repairs or correcting malfunctions).

8B-1 Inspection and Service

WARNING

- Perform periodic service. Failure to perform service may result in an accident.

8B-1-1 Inspection Items

Check the following inspection items periodically for any abnormalities.

- (1) Level Adjuster Inspection
 - Check that the level adjusters are fixed securely. (See "8A-2-2 Level Adjuster Adjustment" on page 90.)
- (2) Power Cord Plug Inspection
 - Check that the power cord is firmly inserted into the power outlet in the machine's cord box.
 - Clean any dust or other dirt from the connection parts.
 - Check for cracks or dirt on the power cord covering. If there is any abnormality on the power cord, be sure to replace it.
- (3) Screw Looseness Inspection

Check the following parts for loose screws. Fully retighten any loose screws.

 - Corner covers and goal covers (See "8A-2-1 (1) Assembling the Table, Goals and Corner Covers" on page 75.)
 - Net L and S, center guard, and side wall (See "8A-2-1 (2) Installing the Nets" on page 86.)
 - Goal bumpers (L) and (R), bumpers S (L) and (R), bumper L, and corner bumpers

- 1
- 2
- 3
- 4
- 5
- 6
- 7
- 8A
- 8B
- 9
- 10
- 11
- 12

Opening and Closing Doors / Inspection and Service

Test Mode

Troubleshooting

- Must be performed by a technician -

8B-1-2 Cleaning the Puck Paths

(1) Cleaning the Insides of the Goal (L) and (R) Assemblies

The description below explains how to clean the (L) side. Follow the same procedure to clean the (R) side.

WARNING

- To avoid electric shock, accidents or injuries to yourself or other people, or damage to the electronic circuits, be sure to turn off the power switch before starting work.

NOTICE

- Do not use thinner, benzene, gasoline, alcohol or other organic solvents. This may degrade the materials.

- 1** Turn off the power switch. (See “7-6-1 Turning the Power Switch On” on page 39.)
- 2** Open the goal (L) assembly. (See “7-5-3 Opening and Closing the Goal (L) and (R) Assemblies” on page 38.)
- 3** Wipe away any dirt from the puck paths using a soft cloth moistened with water or a neutral cleanser diluted with water and then firmly wrung out.

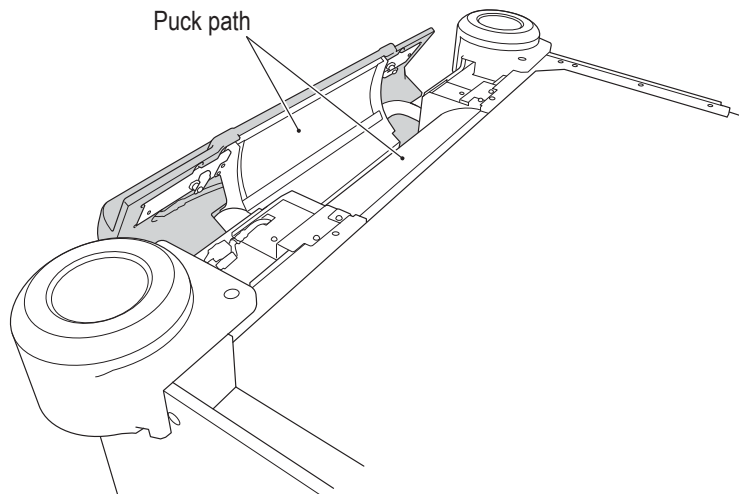

- 4** Wipe dry using a soft cloth so that no water or detergent remains, and then allow to dry completely.
- 5** To install, perform the procedure in reverse.

- Must be performed by a technician -

(2) Cleaning the Rail (L) and (R) Assemblies

The description below explains how to clean the (L) side. Follow the same procedure to clean the (R) side.

! WARNING

- To avoid electric shock, accidents or injuries to yourself or other people, or damage to the electronic circuits, be sure to turn off the power switch before starting work.

NOTICE

- Do not use thinner, benzene, gasoline, alcohol or other organic solvents. This may degrade the materials.

- 1** Turn off the power switch. (See "7-6-1 Turning the Power Switch On" on page 39.)
- 2** Remove the rail (L) assembly by reversing the installation procedure. (See steps **5** - **9** of "8A-2-5 Installing the Side Tower Assembly" on page 96.)
- 3** Wipe away any dirt from the puck paths using a soft cloth moistened with water or a neutral cleanser diluted with water and then firmly wrung out.
* Use a cotton swab to clean narrow parts.

Rail (L) assembly

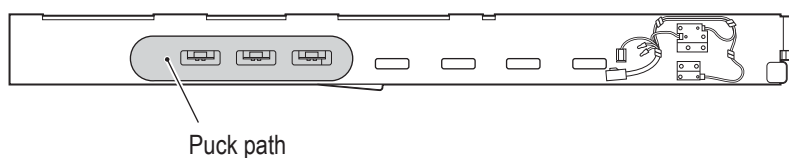

Rail (R) assembly

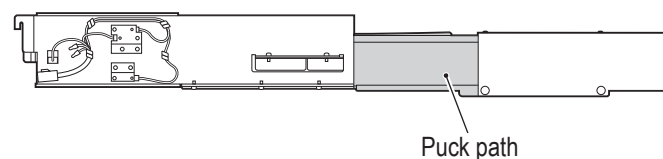

- 4** Wipe dry using a soft cloth so that no water or detergent remains, and then allow to dry completely.
- 5** To install, perform the procedure in reverse.

1

2

3

4

5

6

7

8A

8B

9

10

11

12

Inspection and Service

Test Mode

Troubleshooting

- Must be performed by a technician -

(3) Cleaning the Insides of the L and S Buckets (Hopper Assembly)

⚠ WARNING

- To avoid electric shock, accidents or injuries to yourself or other people, or damage to the electronic circuits, be sure to turn off the power switch before starting work.

NOTICE

- Do not perform the following operations. Doing so may cause pucks to jam or other malfunctions.
 - Rotating the L hopper disk in the clockwise direction as viewed from above.
 - Rotating the S hopper disk in the counter-clockwise direction as viewed from above.
- Do not use thinner, benzene, gasoline, alcohol or other organic solvents. This may degrade the materials.

- 1** Turn off the power switch. (See "7-6-1 Turning the Power Switch On" on page 39.)
- 2** Remove the side tower assembly. (See "8B-4-4 (1) Removing and Installing the Side Tower Assembly" on page 145.)
- 3** Remove any pucks from inside the L and S buckets.

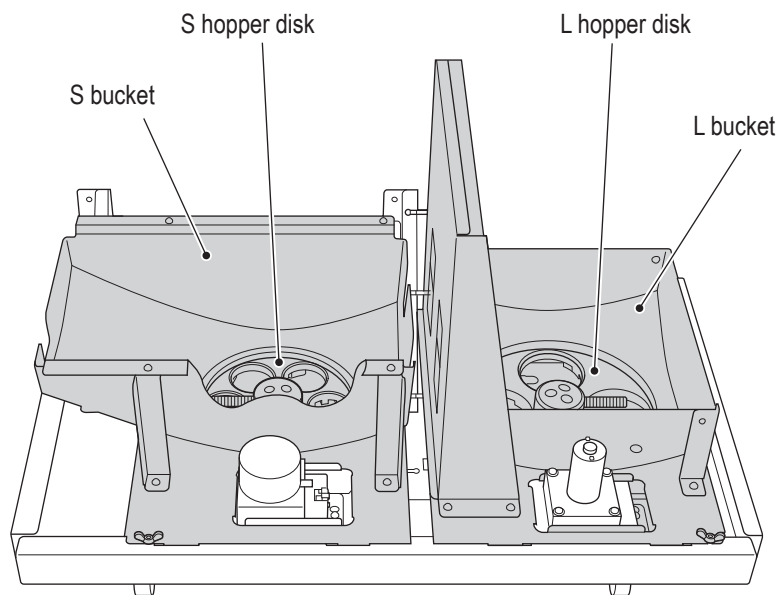

- 4** Wipe away any dirt from the puck paths using a soft cloth moistened with water or a neutral cleanser diluted with water and then firmly wrung out.
 - * Use a cotton swab to clean narrow parts.
- 5** Wipe dry using a soft cloth so that no water or detergent remains, and then allow to dry completely.
- 6** To install, perform the procedure in reverse.

- Must be performed by a technician -

(4) Cleaning the Hopper Disks and Hopper Bottoms (Hopper Assembly)

The description below explains how to clean the S hopper disk. Follow the same procedure to clean the L hopper disk.

! WARNING

- To avoid electric shock, accidents or injuries to yourself or other people, or damage to the electronic circuits, be sure to turn off the power switch before starting work.

NOTICE

- Do not perform the following operations. Doing so may cause pucks to jam or other malfunctions.
 - Rotating the L hopper disk in the clockwise direction as viewed from above.
 - Rotating the S hopper disk in the counter-clockwise direction as viewed from above.
- Do not use thinner, benzene, gasoline, alcohol or other organic solvents. This may degrade the materials.

- 1** Turn off the power switch. (See "7-6-1 Turning the Power Switch On" on page 39.)
- 2** Remove the side tower assembly. (See "8B-4-4 (1) Removing and Installing the Side Tower Assembly" on page 145.)
- 3** Remove any pucks from inside the S bucket.
- 4** Remove the wing bolt (M4 x 6), slide the S hopper cover toward the outside, and remove it.

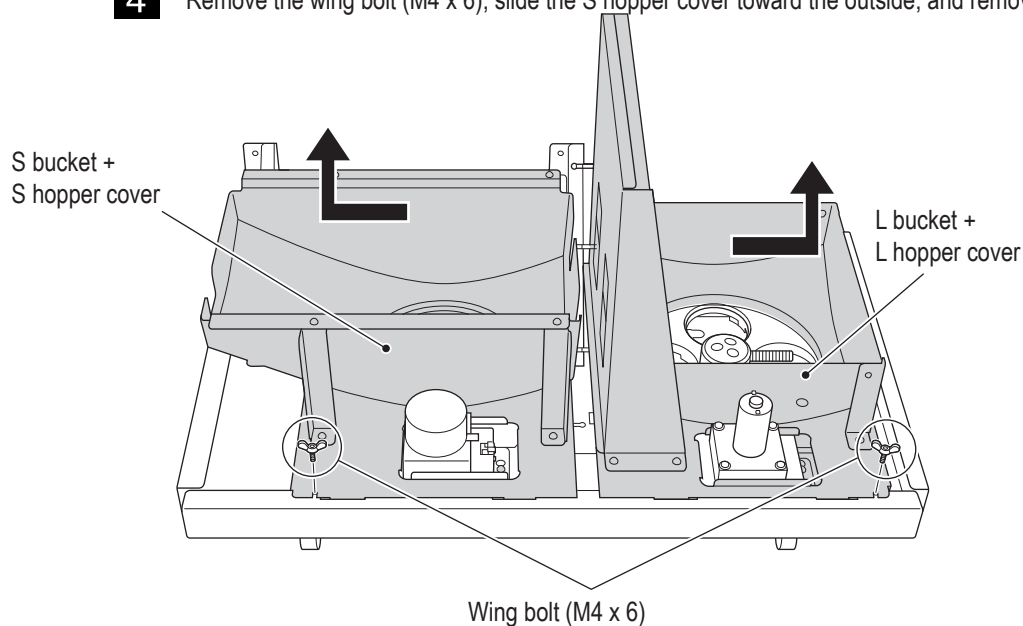

8B. Service

- Must be performed by a technician -

- 5** Remove the cord clip and disconnect the two connectors.
- 6** Loosen the four pan head screws (with flat and spring washers) (M4 x 10), and remove the S hopper motor bracket.

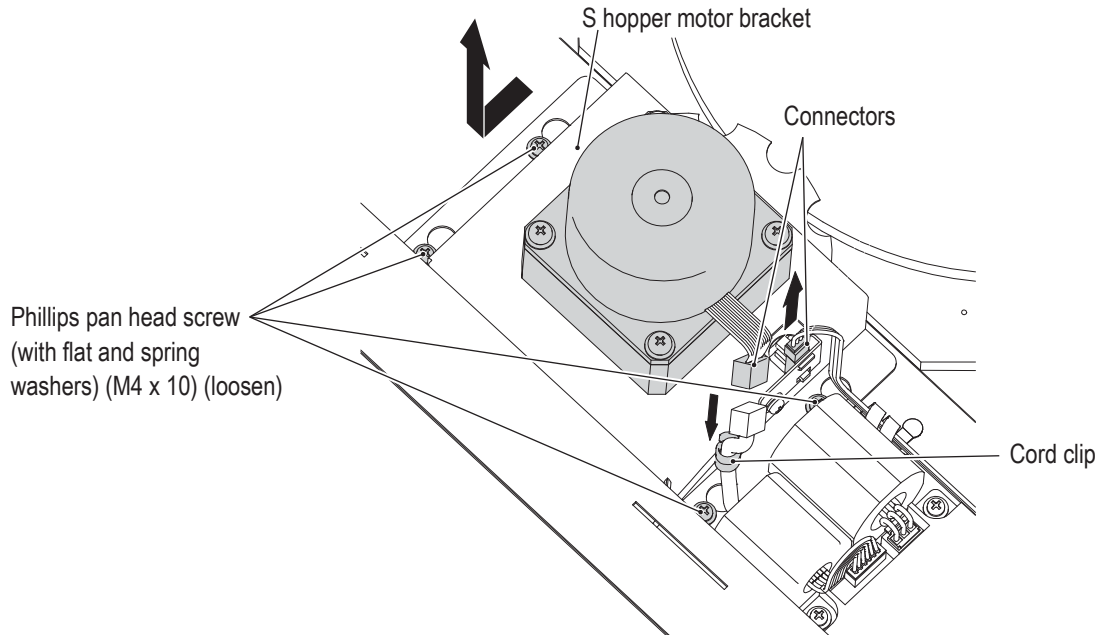

- 7** Remove the three pan head screws (with flat and spring washers) (M4 x 10), and remove the disk top.

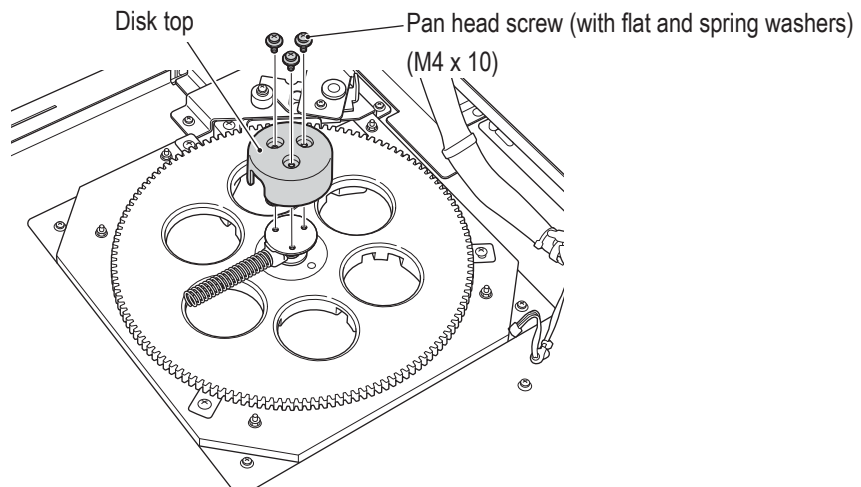

- 8** Remove the pan head screw (with flat and spring washers) (M4 x 10), and remove the hopper spring base.

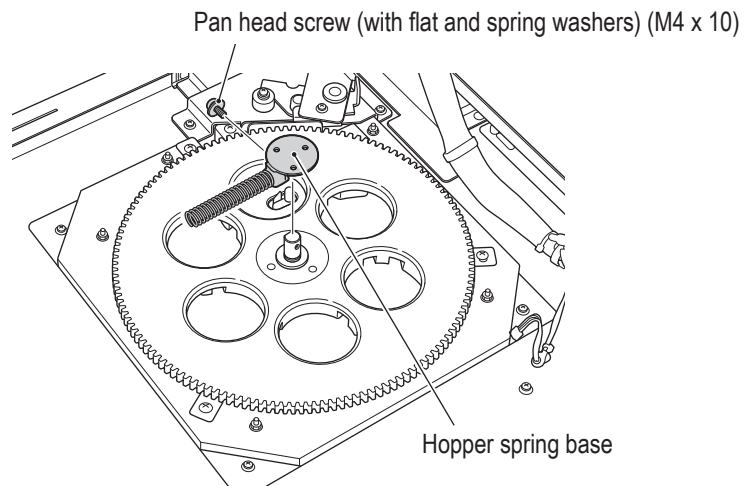

- Must be performed by a technician -

- 9** Remove the two pan head screws (with flat and spring washers) (M4 x 10), and remove the disk retainer bracket. (Perform this step only for the S hopper disk.)

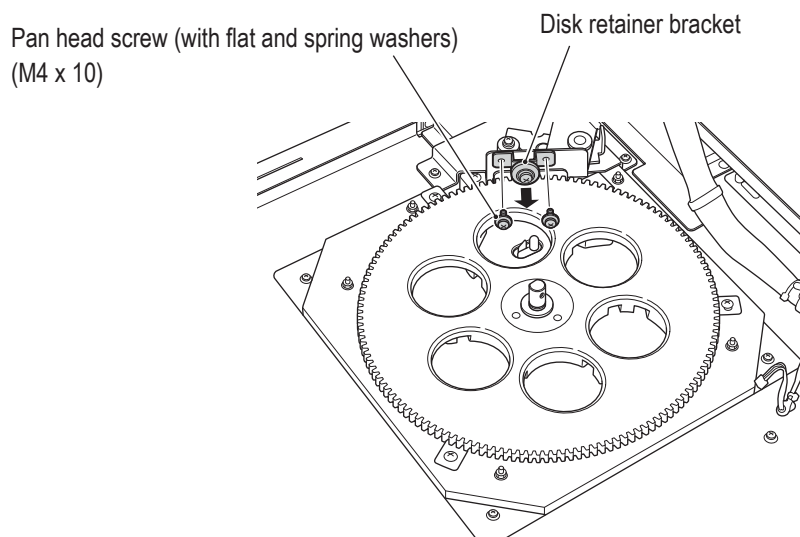

- 10** Remove the E-ring (nominal diameter: 10), and remove the flat washer (M12) and the S hopper disk.

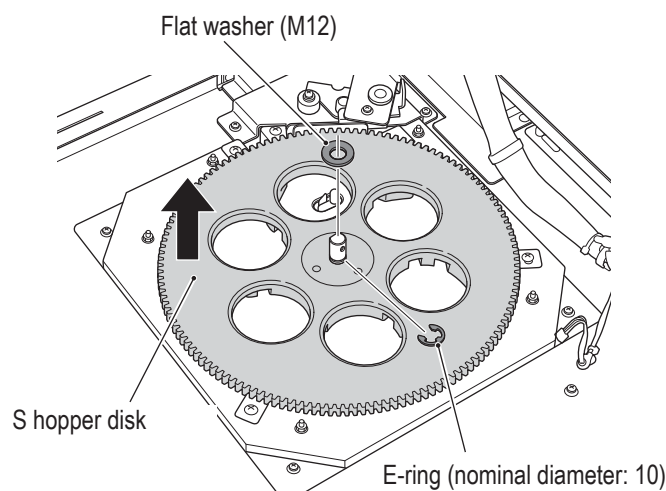

- 11** Wipe away any dirt from the puck paths using a soft cloth moistened with water or a neutral cleanser diluted with water and then firmly wrung out.
- 12** Wipe dry using a soft cloth so that no water or detergent remains, and then allow to dry completely.
- 13** To install, perform the procedure in reverse.



- When installing, press the hopper motor bracket toward the hopper disk so that the hopper gear and hopper disk teeth mesh properly.

1

2

3

4

5

6

7

8A

8B

9

10

11

12

Inspection and Service

Test Mode

Troubleshooting

- Must be performed by a technician -

(5) Cleaning the S Slider Assembly

! WARNING

- To avoid electric shock, accidents or injuries to yourself or other people, or damage to the electronic circuits, be sure to turn off the power switch before starting work.

NOTICE

- Do not use thinner, benzene, gasoline, alcohol or other organic solvents. This may degrade the materials.

- 1** Turn off the power switch. (See "7-6-1 Turning the Power Switch On" on page 39.)
- 2** Remove the illuminator base plates L and R. (See steps **2** - **5** of "8B-4-10 (1) Replacing the Circle LED" on page 170.)
- 3** Remove the three Torx bolts (M5 x 12), and remove the cover panel retainer L.

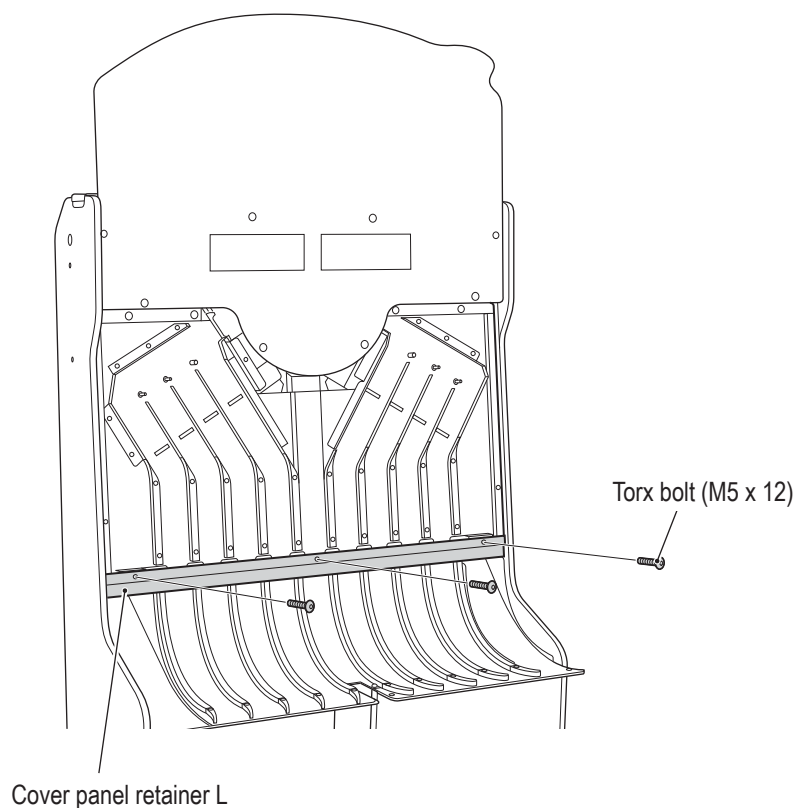



- Must be performed by a technician -

- 4** Remove the two Torx bolts (M5 x 12), and remove the cover panel.

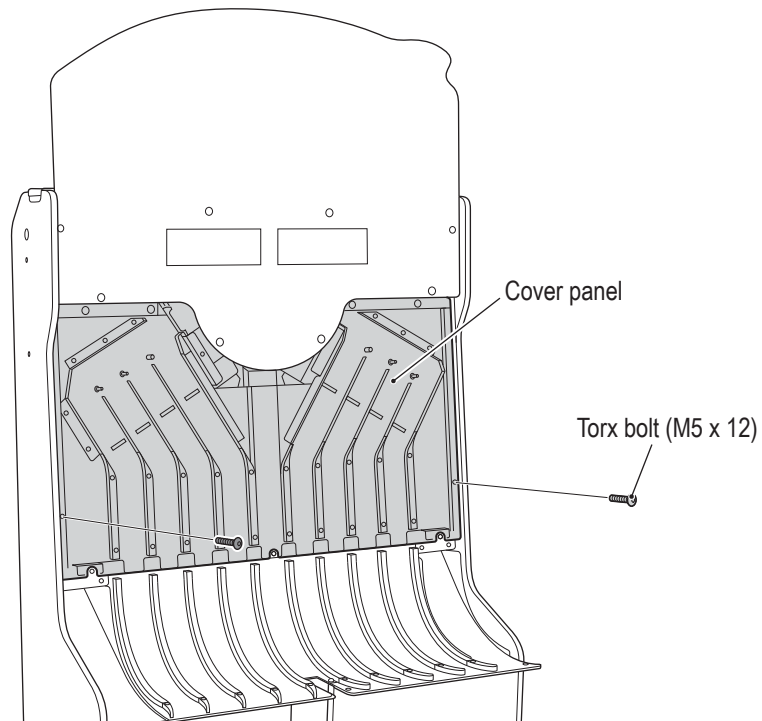

- 5** Wipe away any dirt from the puck paths using a soft cloth moistened with water or a neutral cleanser diluted with water and then firmly wrung out.
- 6** Wipe dry using a soft cloth so that no water or detergent remains, and then allow to dry completely.
- 7** To install, perform the procedure in reverse.

- 1
- 2
- 3
- 4
- 5
- 6
- 7
- 8A
- 8B**
- 9
- 10
- 11
- 12

Inspection and Service

Test Mode

Troubleshooting

- Must be performed by a technician -

8B-1-3 Removing Jammed Pucks



- Check that pucks are not damaged or deformed before putting them back into the machine. Otherwise, the pucks may jam again.

(1) Inside the Goal (L) or (R) Assembly

The description below explains how to remove jammed pucks from the (L) side. Follow the same procedure to remove jammed pucks from the (R) side.

WARNING

- To avoid electric shock, accidents or injuries to yourself or other people, or damage to the electronic circuits, be sure to turn off the power switch before starting work.

- 1** Turn off the power switch. (See “7-6-1 Turning the Power Switch On” on page 39.)
- 2** Open the goal (L) assembly. (See “7-5-3 Opening and Closing the Goal (L) and (R) Assemblies” on page 38.)
- 3** Remove the jammed puck.
- 4** To install, perform the procedure in reverse.

(2) In case of the rail (L)/(R) assembly

The description below explains how remove jammed pucks from the (L) side. Follow the same procedure to remove jammed pucks from the (R) side.

WARNING

- To avoid electric shock, accidents or injuries to yourself or other people, or damage to the electronic circuits, be sure to turn off the power switch before starting work.

- 1** Turn off the power switch. (See “7-6-1 Turning the Power Switch On” on page 39.)
- 2** Remove the rail (L) assembly by reversing the installation procedure. (See steps **5** - **9** of “8A-2-5 Installing the Side Tower Assembly” on page 96.)
- 3** Remove the jammed puck.
- 4** To install, perform the procedure in reverse.

- Must be performed by a technician -

(3) Inside the Corner Rail (L) or (R)

The description below explains how to remove jammed pucks from the (L) side. Follow the same procedure to remove jammed pucks from the (R) side.

! WARNING

- To avoid electric shock, accidents or injuries to yourself or other people, or damage to the electronic circuits, be sure to turn off the power switch before starting work.

- 1** Turn off the power switch. (See "7-6-1 Turning the Power Switch On" on page 39.)
- 2** Open the service door L. (See "8A-5-2 Opening and Closing the Service Doors L and R" on page 107.)
- 3** Insert a rod (wrench, etc.) into the gap of the corner outer R (L), and remove the jammed puck.

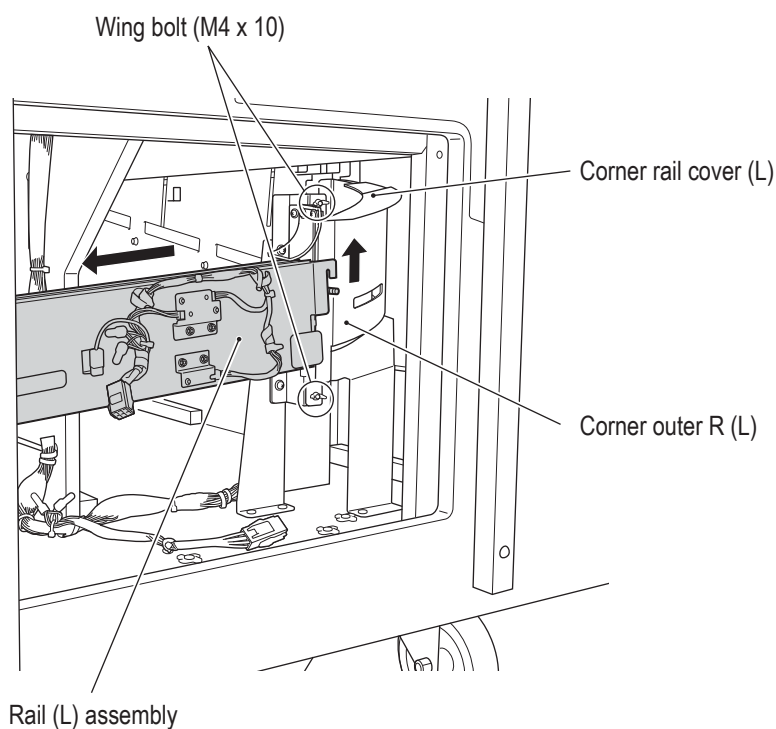

[If the jammed puck cannot be removed by the above procedure, perform the procedure below.]

- 4** Remove the rail (L) assembly by reversing the installation procedure. (See steps **5** - **9** of "8A-2-5 Installing the Side Tower Assembly" on page 96.)
- 5** Remove the two wing bolts (M4 x 10), and remove the corner rail cover (L).
- 6** Open the corner outer R (L) slightly, insert a rod (wrench, etc.) into the gap, and remove the jammed puck.
- 7** To install, perform the procedure in reverse.

- Must be performed by a technician -

(4) Inside the L or S Bucket (Hopper Assembly)

WARNING

- To avoid electric shock, accidents or injuries to yourself or other people, or damage to the electronic circuits, be sure to turn off the power switch before starting work.

- 1** Turn off the power switch. (See "7-6-1 Turning the Power Switch On" on page 39.)
- 2** Remove the side tower assembly. (See "8B-4-4 (1) Removing and Installing the Side Tower Assembly" on page 145.)
- 3** Remove any pucks from inside the L or S bucket, and then remove the jammed puck.
- 4** To install, perform the procedure in reverse.

(5) Inside a Hopper Disk or Hopper Bottom (Hopper Assembly)

The description below explains how to remove jammed pucks from the S hopper disk. Follow the same procedure to remove jammed pucks from the L hopper disk.

WARNING

- To avoid electric shock, accidents or injuries to yourself or other people, or damage to the electronic circuits, be sure to turn off the power switch before starting work.

NOTICE

Do not perform the following operations. Doing so may cause pucks to jam or other malfunctions.

- Rotating the L hopper disk in the clockwise direction as viewed from above.
- Rotating the S hopper disk in the counter-clockwise direction as viewed from above.

- 1** Turn off the power switch. (See "7-6-1 Turning the Power Switch On" on page 39.)
- 2** Remove the side tower assembly. (See "8B-4-4 (1) Removing and Installing the Side Tower Assembly" on page 145.)
- 3** Remove the S hopper disk. (See steps **3** - **10** of "8B-1-2 (4) Cleaning the Hopper Disks and Hopper Bottoms (Hopper Assembly)" on page 113.)
- 4** Remove the jammed puck.
- 5** To install, perform the procedure in reverse.

- Must be performed by a technician -

(6) In case of S Escalator Assembly

The description below explains how to remove jammed pucks from the L side. Follow the same procedure to remove jammed pucks from the R side.

! WARNING

- To avoid electric shock, accidents or injuries to yourself or other people, or damage to the electronic circuits, be sure to turn off the power switch before starting work.

- 1** Turn off the power switch. (See "7-6-1 Turning the Power Switch On" on page 39.)
- 2** Remove the rear panel. (See "8A-5-3 Opening and Closing the Rear Panel" on page 108.)
- 3** Remove the four Hex nuts with flange (M4), disconnect the connector, and remove the joint rail cover L.

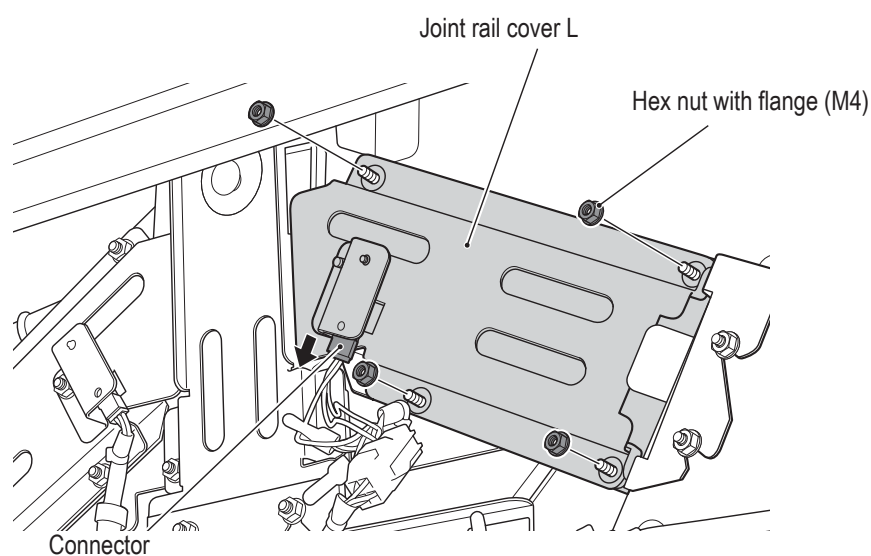

- 4** Remove the jammed puck.

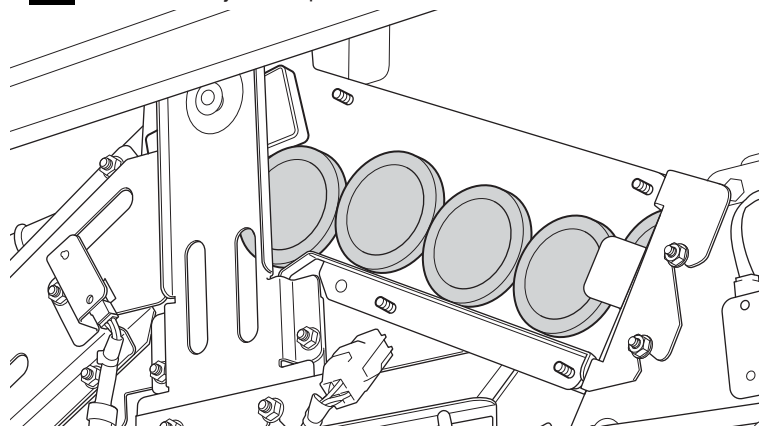

- 5** To install, perform the procedure in reverse.

1

2

3

4

5

6

7

8A

8B

9

10

11

12

Inspection and Service

Test Mode

Troubleshooting

- Must be performed by a technician -

(7) In case of L Escalator Assembly

⚠ WARNING

- To avoid electric shock, accidents or injuries to yourself or other people, or damage to the electronic circuits, be sure to turn off the power switch before starting work.

- 1** Turn off the power switch. (See "7-6-1 Turning the Power Switch On" on page 39.)
- 2** Remove the rear panel. (See "8A-5-3 Opening and Closing the Rear Panel" on page 108.)
- 3** Disconnect the connector.
- 4** Remove the four Hex nuts with flange (M4), loosen the two Hex nuts with flange (M4), and remove the L rail (H) cover.

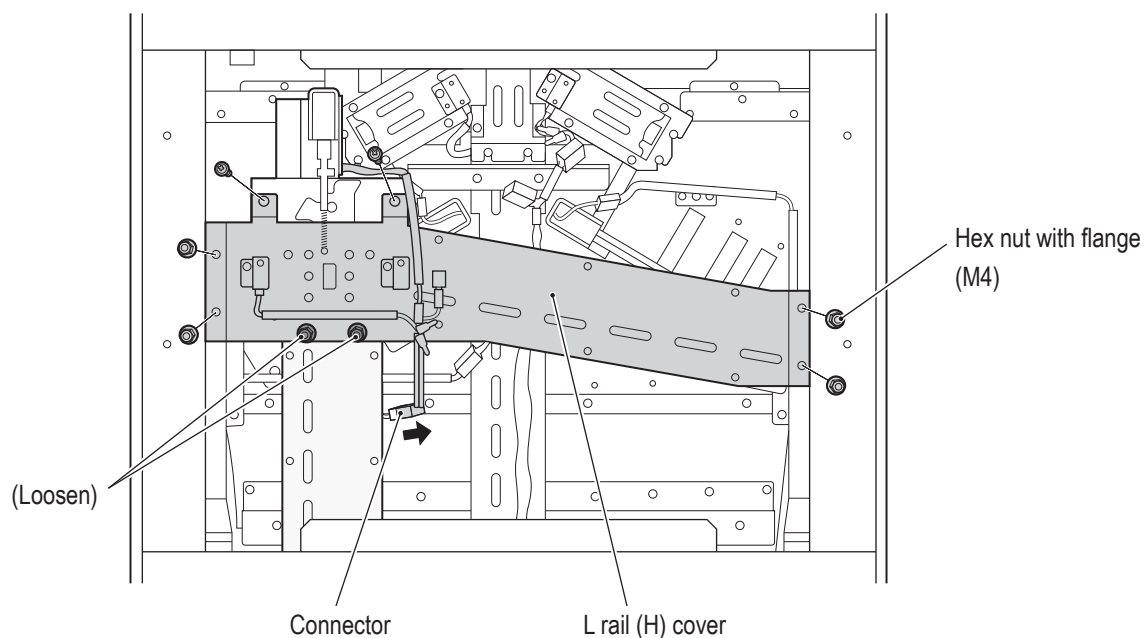

- 5** Remove the jammed puck.
- 6** To install, perform the procedure in reverse.



- Must be performed by a technician -

(8) In case of the Slider Assembly

! WARNING

● To avoid electric shock, accidents or injuries to yourself or other people, or damage to the electronic circuits, be sure to turn off the power switch before starting work.

- 1** Turn off the power switch. (See "7-6-1 Turning the Power Switch On" on page 39.)
- 2** Remove the cover panel. (See steps **2** - **4** of "8B-1-2 (5) Cleaning the S Slider Assembly" on page 116.)
- 3** Remove the jammed puck.
- 4** To install, perform the procedure in reverse.

- 1
- 2
- 3
- 4
- 5
- 6
- 7
- 8A
- 8B**
- 9
- 10
- 11
- 12

Inspection and Service

Test Mode

Troubleshooting

- Must be performed by a technician -

8B-1-4 Adding Big Pucks

WARNING

● To avoid electric shock, accidents or injuries to yourself or other people, or damage to the electronic circuits, be sure to turn off the power switch before starting work.

- 1** Turn off the power switch. (See “7-6-1 Turning the Power Switch On” on page 39.)
- 2** Open the service door R. (See “8A-5-2 Opening and Closing the Service Doors L and R” on page 107.)
- 3** Count the number of big pucks inside the L bucket.

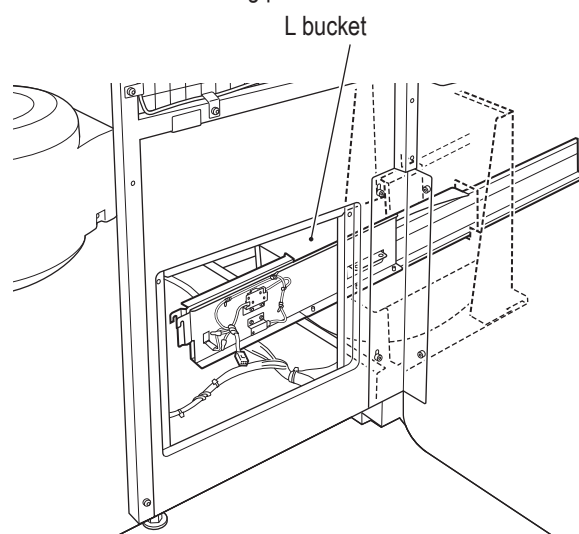

- 4** Add big pucks so that there are 20 to 30 big pucks inside the L bucket.
- 5** To install, perform the procedure in reverse.

- Must be performed by a technician -

8B-2 Error Display (for Technicians)

8B-2-1 Display when an Error Occurs

When an error occurs, "Err" is displayed in the left side score LED, and the error number is displayed in the right side score LED. The same error number is displayed as a binary value in the time LED.

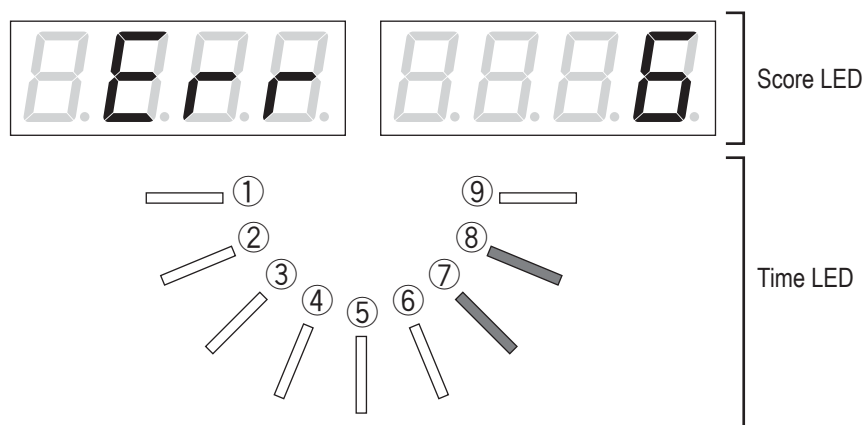

Signboard display (when error number = 6)



- Before checking for a malfunction, first make sure that all the connectors are connected securely.

8B-2-2 Resolving Errors

Error number	Error name	Cause	Action	Reference page
1	Coin switch error	• A coin selector malfunction.	• Replace the coin selector.	—
		• Main PC board malfunction.	• Replace the main PC board.	Page 146
2	Service switch error	• Service button malfunction.	• Contact your distributor.	—
		• Main PC board malfunction.	• Replace the main PC board.	Page 146
3	Sound IC error	• Main PC board malfunction.	• Replace the main PC board.	Page 146
4	Communication error with time LED PC board	• A time LED PC board malfunction.	• Replace the time LED PC board.	Page 168
		• Main PC board malfunction.	• Replace the main PC board.	Page 146
5	Communication error with score LED PC board	• A score LED PC board malfunction.	• Replace the score LED PC board.	Page 169
		• Main PC board malfunction.	• Replace the main PC board.	Page 146

8B. Service

- Must be performed by a technician -

Error number	Error name	Cause	Action	Reference page
6	Goal (L) sensor error	• A puck or foreign object is jammed inside the L side goal.	• Remove the jammed puck or foreign object from inside the goal (L).	Page 118
		• A puck or foreign object is jammed inside the corner rail (L).	• Remove the jammed puck or foreign object from inside the goal (L).	Page 119
		• The goal (L) sensor is dirty.	• Clean the inside of the goal (L) sensor.	Page 141
		• Goal (L) sensor malfunction.	• Replace the goal (L) sensor.	Page 141
7	Goal (R) sensor error	• A puck or foreign object is jammed inside the R side goal.	• Remove the jammed puck or foreign object from inside the goal (R).	Page 118
		• A puck or foreign object is jammed inside the corner rail (R).	• Remove the jammed puck or foreign object from inside the goal (R).	Page 119
		• The goal (R) sensor is dirty.	• Clean the inside of the goal (R) sensor.	Page 141
		• Goal (R) sensor malfunction.	• Replace the goal (R) sensor.	Page 141
8	Stopper solenoid (L) error	• Stopper solenoid (L) malfunction.	• Replace the stopper solenoid (L).	Page 161
		• Stopper (L) sensor malfunction.	• Replace the stopper (L) sensor.	Page 163
		• Switching regulator (24V) malfunction.	• Replace the switching regulator (24V).	Page 148
9	Stopper solenoid (R) error	• Stopper solenoid (R) malfunction.	• Replace the stopper solenoid (R).	Page 161
		• Stopper (R) sensor malfunction.	• Replace the stopper solenoid (R) sensor.	Page 163
		• Switching regulator (24V) malfunction.	• Replace the switching regulator (24V).	Page 148
10	L divider solenoid error	• L divider solenoid malfunction.	• Replace the L divider solenoid.	Page 165
		• L divider sensor malfunction.	• Replace the L divider sensor.	Page 166
		• Switching regulator (24V) malfunction.	• Replace the switching regulator (24V).	Page 148

- Must be performed by a technician -

Error number	Error name	Cause	Action	Reference page
11	S hopper motor error	• A mini puck is jammed inside the hopper.	• Remove the jammed puck.	Page 120
		• A foreign object other than a mini puck has entered the hopper.	• Remove the foreign object from inside the hopper.	Page 112
		• S hopper sensor malfunction.	• Replace the S stopper sensor.	Page 158
		• S hopper motor malfunction.	• Replace the S stopper motor.	Page 155
12	L hopper motor error	• A big puck is jammed inside the hopper.	• Remove the jammed puck.	Page 120
		• A foreign object other than a big puck has entered the hopper.	• Remove the foreign object from inside the hopper.	Page 112
		• L hopper motor sensor malfunction.	• Replace the L hopper motor sensor.	Page 154
		• L hopper motor malfunction.	• Replace the L hopper motor.	Page 150
		• Switching regulator (24V) malfunction.	• Replace the switching regulator (24V).	Page 148
13	S hopper idling error	• There are no mini pucks inside the hopper.	• Add mini pucks to the hopper.	Page 105
		• A puck is standing on edge inside the hopper.	• Remove all of the pucks from the hopper, and then put the pucks back into the hopper correctly.	Page 120
		• A mini puck is jammed inside the hopper.	• Remove the jammed puck.	Page 120
		• S divider outlet sensor malfunction.	• Replace the S divider outlet sensor.	Page 164
14	L hopper idling error	• There are no big pucks inside the hopper.	• Add big pucks to the hopper.	Page 105
		• A puck is standing on edge inside the hopper.	• Remove all of the pucks from the hopper, and then put the pucks back into the hopper correctly.	Page 120
		• A big puck is jammed inside the hopper.	• Remove the jammed puck.	Page 120
		• L divider outlet sensor malfunction.	• Replace the L divider outlet sensor.	Page 167

1

2

3

4

5

6

7

8A

8B

9

10

11

12

Error Display (for Technicians)

Test Mode

Troubleshooting

8B. Service

- Must be performed by a technician -

Error number	Error name	Cause	Action	Reference page
15	Rail (L) jamming error	<ul style="list-style-type: none"> A puck is jammed inside the rail (L). 	<ul style="list-style-type: none"> Remove the jammed puck. 	Page 118
16	Rail (R) jamming error	<ul style="list-style-type: none"> A puck is jammed inside the rail (R). 		
17	S divider (L) outlet sensor error	<ul style="list-style-type: none"> A puck is jammed in the S divider outlet. 	<ul style="list-style-type: none"> Remove the jammed puck. 	Page 121
18	S divider (R) outlet sensor error			
19	Corner rail jamming error (L)	<ul style="list-style-type: none"> A puck is jammed inside the corner rail. 	<ul style="list-style-type: none"> Remove the jammed puck. 	Page 119
		<ul style="list-style-type: none"> The rail (L) sensor is dirty. 	<ul style="list-style-type: none"> Clean the inside of the rail (L) sensor. 	Page 145
		<ul style="list-style-type: none"> The rail (L) sensor malfunction. 	<ul style="list-style-type: none"> Replace the rail (L) sensor. 	Page 145
20	Corner rail jamming error (R)	<ul style="list-style-type: none"> A puck is jammed inside the corner rail. 	<ul style="list-style-type: none"> Remove the jammed puck. 	Page 119
		<ul style="list-style-type: none"> The rail (R) sensor is dirty. 	<ul style="list-style-type: none"> Clean the inside of the rail (R) sensor. 	Page 145
		<ul style="list-style-type: none"> The rail (R) sensor malfunction. 	<ul style="list-style-type: none"> Replace the rail (R) sensor. 	Page 145
21	S divider (L) outlet sensor skip error	<ul style="list-style-type: none"> S divider (L) outlet sensor is dirty. 	<ul style="list-style-type: none"> Clean the S divider (L) outlet sensor. 	Page 168
		<ul style="list-style-type: none"> S divider (L) outlet sensor malfunction. 	<ul style="list-style-type: none"> Replace the S divider (L) outlet sensor. 	Page 168
22	S divider (R) outlet sensor skip error	<ul style="list-style-type: none"> S divider (R) outlet sensor is dirty. 	<ul style="list-style-type: none"> Clean the S divider (R) outlet sensor. 	Page 168
		<ul style="list-style-type: none"> S divider (R) outlet sensor malfunction. 	<ul style="list-style-type: none"> Replace the S divider (R) outlet sensor. 	Page 168
23	S hopper motor sensor error	<ul style="list-style-type: none"> S hopper motor sensor is dirty. 	<ul style="list-style-type: none"> Replace the S hopper motor sensor. 	Page 160
		<ul style="list-style-type: none"> S hopper motor sensor malfunction. 	<ul style="list-style-type: none"> Replace the S hopper motor sensor. 	Page 160
24	L hopper motor sensor error	<ul style="list-style-type: none"> L hopper motor sensor is dirty. 	<ul style="list-style-type: none"> Replace the L hopper motor sensor. 	Page 156
		<ul style="list-style-type: none"> L hopper motor sensor malfunction. 	<ul style="list-style-type: none"> Replace the L hopper motor sensor. 	Page 156

- Must be performed by a technician -

Error number	Error name	Cause	Action	Reference page
25	Ticket dispenser (L) error	<ul style="list-style-type: none"> The dispenser has run out of tickets. A ticket dispenser (L) malfunction. 	<ul style="list-style-type: none"> Add tickets. Replace the ticket dispenser (L). 	—
26	Ticket dispenser (R) error	<ul style="list-style-type: none"> The dispenser has run out of tickets. A ticket dispenser (R) malfunction. 	<ul style="list-style-type: none"> Add tickets. Replace the ticket dispenser (R). 	—
99	Start-up error	<ul style="list-style-type: none"> The power switch was turned off, and then immediately turned back on again. 	<ul style="list-style-type: none"> Turn off the power switch, wait for 30 seconds or more, and then turn on the power switch again. 	Page 106

1

2

3

4

5

6

7

8A

8B

9

10

11

12

Error Display (for Technicians)

Test Mode

Troubleshooting

- Must be performed by a technician -

8B-3 Troubleshooting

WARNING

- To avoid electric shock, accidents or injuries to yourself or other people, or damage to the electronic circuits, be sure to turn off the power switch before starting work.
- If the problem is not described in "8B-3 Troubleshooting" or the problem persists despite taking the appropriate action, turn off the power switch immediately to stop operation, and contact your distributor. Continuing operations may result in an accident.

NOTICE

- Before checking for a malfunction, first make sure that all the connectors are connected securely.
- Never perform a conductivity check of the boards with a tester or any other tool. The IC may be damaged by the internal voltage of the tester.
- When sending parts for repair, be sure to pack them properly. Particularly when sending the main PC board, wrap the part in sponge or air bubble wrapping before packing it in a cardboard box to make sure that the part is not exposed to external force.

- Must be performed by a technician -

8B-3-1 Overall

Symptom	Main cause	Action	Reference page
The machine does not start even when the power switch is turned on.	The power cord is disconnected from the outlet or the machine, or is not connected securely.	<ul style="list-style-type: none"> Connect the power cord correctly and securely. Turn on the power switch again. 	Page 106
	The PCB base is not installed correctly.	Install the PCB base correctly.	Page 146
	Main PC board malfunction.	Replace the main PC board.	Page 146
	Switching regulator malfunction.	Replace the switching regulator.	Page 148
Operation is not stable.	The power supply voltage is not within the range of AC 110 V to 130 V (or 210 V to 230 V).	Disconnect any high-capacity devices (such as an air conditioner or large machine) from the same line to secure the specified power supply voltage.	—
The power turns off during operation.	<p>The circuit protector has operated to turn off the power switch.</p> <p>*The circuit protector turns off the current when an abnormal current occurs.</p>	<p>Turn on the power switch again.</p> <p>If the circuit protector operates frequently, there is a mechanical abnormality.</p> <p>Contact your distributor.</p>	—

8B-3-2 Table top assembly

Symptom	Main cause	Action	Reference page
The pucks do not slide.	The machine is in Attract (standby) mode.	When the game starts, the blower fan operates so that the pucks slide.	Page 40
	The inside of the playing field.	Clean the playing field.	Page 70
	A puck is deformed.	Replace the deformed puck with a spare puck.	Page 105
	A puck is dirty.	Clean the puck.	Page 71
	The blower fan malfunction.	Replace the blower fan.	Page 139
	SSR malfunction.	Replace the SSR.	Page 149

1

2

3

4

5

6

7

8A

8B

9

10

11

12

Troubleshooting

Test Mode

Troubleshooting

8B. Service

- Must be performed by a technician -

8B-3-3 Goal (L) and (R) Assemblies

Symptom	Main cause	Action	Reference page
Pucks jam frequently.	One or both of the goal coin locks are not closed.	Use the service key and close the goal.	Page 38
	A deformed puck is being used.	Replace the deformed puck with a spare puck.	Page 105
	A puck is dirty.	Clean the puck.	Page 71
	A foreign object has entered the goal.	Remove the foreign object.	Page 110
	The inside of the goal is dirty.	Clean the inside of the goal.	Page 110
Sound is not output.	The volume setting is low.	Adjust the volume.	Page 39
	Main PC board malfunction.	Replace the main PC board.	Page 146

8B-3-4 Rail (L) and (R) Assemblies

Symptom	Main cause	Action	Reference page
Pucks jam frequently.	The rail is not installed correctly.	Install the rail correctly.	Page 96
	A deformed puck is being used.	Replace the deformed puck with a spare puck.	Page 105
	A puck is dirty.	Clean the puck.	Page 71
	A foreign object has entered the rail.	Remove the foreign object.	Page 111
	The inside of the rail is dirty.	Clean the inside of the rail.	Page 111

8B-3-5 Coin Assembly

Symptom	Main cause	Action	Reference page
The game does not start even when sufficient coins are inserted.	Coin selector malfunction.	Replace the coin selector.	—
	Main PC board malfunction.	Replace the main PC board.	Page 146

- Must be performed by a technician -

8B-3-6 Hopper assembly

Symptom	Main cause	Action	Reference page
The hopper disk does not operate.	A foreign object has entered the hopper.	Remove the side tower assembly, and remove the foreign object from inside the hopper.	Page 120
	A puck is jammed inside the hopper.	Remove the side tower assembly, and remove all pucks from inside the hopper.	Page 120
	The hopper motor bracket is not installed correctly.	Install the hopper motor bracket correctly.	Page 150
	The hopper gear is not installed correctly.	Install the hopper gear correctly.	Page 150
	Hopper motor malfunction.	Replace the hopper motor.	Page 150
	Hopper motor driver PC board malfunction.	Replace the hopper motor driver PC board.	Page 159
	Switching regulator (24V) malfunction.	Replace the switching regulator (24V).	Page 148
	Main PC board malfunction.	Replace the main PC board.	Page 146
The hopper disk operates, but pucks do not come out.	There are not enough pucks.	Add spare pucks to the hopper.	Page 105
	A puck is standing on edge inside the hopper.	Remove the side tower assembly, remove all pucks from inside the hopper, and then put the pucks back into the hopper correctly.	Page 120
	The hopper spring is not installed correctly.	Install the hopper spring correctly.	Page 113
Mini pucks frequently mix into the L hopper.	The pendulum stopper on rail (L) assembly is not installed correctly.	Install the pendulum stopper correctly.	—
	The rail (R) assembly puck paths are dirty.	Clean the puck paths.	Page 111

1

2

3

4

5

6

7

8A

8B

9

10

11

12

Troubleshooting

Test Mode

Troubleshooting

8B. Service

- Must be performed by a technician -

8B-3-7 Slider Assembly

Symptom	Main cause	Action	Reference page
Mini pucks are not supplied during game play.	Normal Hockey Mode was selected at the start of the game.	Select Big Bang Mode at the start of the game.	Page 40
	The machine is set to operate in Normal Hockey Mode only.	Change the setting to "OFF".	Page 67
	There are not enough pucks.	Add spare pucks to the hopper.	Page 105
	One or more deformed pucks is mixed into the pucks.	Remove any deformed pucks, and replace with spare pucks.	Page 105
	The stopper base is not installed correctly.	Install the stopper base correctly.	Page 161
	Stopper solenoid malfunction.	Replace the stopper solenoid.	Page 161
	Main PC board malfunction.	Replace the main PC board.	Page 146
	Switching regulator (24V) malfunction.	Replace the switching regulator (24V).	Page 148
S (mini) pucks stack and become jammed.	The cover panel is not installed correctly.	Install the cover panel correctly.	Page 116
	The illuminator assembly is not installed correctly.	Install the illuminator assembly correctly.	Page 170

8B-3-8 S Escalator Assembly

Symptom	Main cause	Action	Reference page
Pucks remain inside the joint rail cover.	S divider outlet sensor malfunction.	Replace the S divider outlet sensor.	Page 164

8B-3-9 L Escalator assembly

Symptom	Main cause	Action	Reference page
Multiple big pucks are supplied at once.	The L rail (H) cover is not installed correctly.	Install the L rail (H) cover correctly.	Page 122
	L divider outlet sensor malfunction.	Replace the L divider outlet sensor.	Page 167
L divider solenoid does not operate.	A foreign object has entered the L escalator assembly.	Remove the L rail (H) cover, and remove the foreign object.	Page 122
	L divider solenoid malfunction.	Replace the L divider solenoid.	Page 165
	Switching regulator (24V) malfunction.	Replace the switching regulator (24V).	Page 148



- Must be performed by a technician -

8B-3-10 Signboard assembly

Symptom	Main cause	Action	Reference page
The time LED PC board does not light.	A time LED PC board malfunction.	Replace the time LED PC board.	Page 168
	Main PC board malfunction.	Replace the main PC board.	Page 146
The score LED PC board does not light.	A score LED PC board malfunction.	Replace the score LED PC board.	Page 169
	Main PC board malfunction.	Replace the main PC board.	Page 146

8B-3-11 Illuminator assembly

Symptom	Main cause	Action	Reference page
The circle LED does not light.	A circle LED malfunction.	Replace the circle LED.	Page 170
	Main PC board malfunction.	Replace the main PC board.	Page 146

- 1
- 2
- 3
- 4
- 5
- 6
- 7
- 8A
- 8B**
- 9
- 10
- 11
- 12

Troubleshooting

Test Mode

Troubleshooting

- Must be performed by a technician -

8B-4 Removing, Installing and Replacing Assemblies and Parts

8B-4-1 Table

(1) Removing and Installing the Goal (L) and (R) Assemblies

The description below explains how to remove and install the L side. Follow the same procedure to remove and install the R side.

WARNING

- To avoid electric shock, accidents or injuries to yourself or other people, or damage to the electronic circuits, be sure to turn off the power switch before starting work.

CAUTION

- When lifting up the goal (L) or (R) assembly, be sure to perform the work with two or more people.

- 1 Turn off the power switch. (See "7-6-1 Turning the Power Switch On" on page 39.)
- 2 Remove the two button head bolts (M6 x 40), one button head bolt (M6 x 25) and three flat washers (M6) from each corner cover.

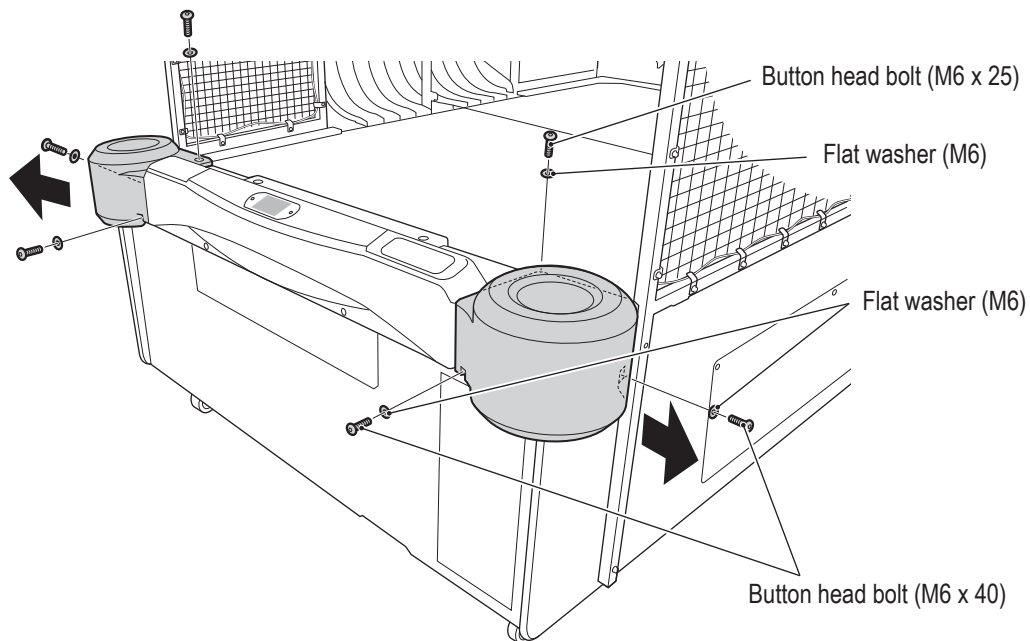

- 3 Slide the corner covers toward the outside, and remove them.

NOTICE

- When removing and installing, be careful not to pinch the harness and connectors.

- 4 Open the goal (L) assembly. (See "7-5-3 Opening and Closing the Goal (L) and (R) Assemblies" on page 38.)

- Must be performed by a technician -

5 Disconnect the two connectors.

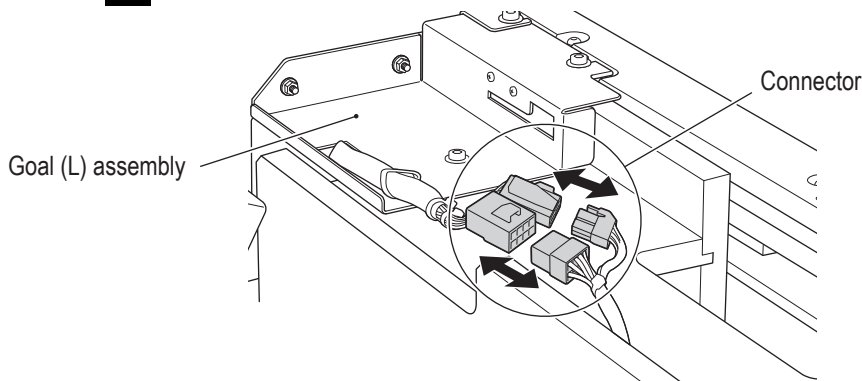

6 Remove the four flange socket bolts (M5 x 10) and two flange socket bolts (M5 x 16) from the right and left of the goal (L) assembly.

NOTICE

● When installing, be sure to use bolts of the specified length.

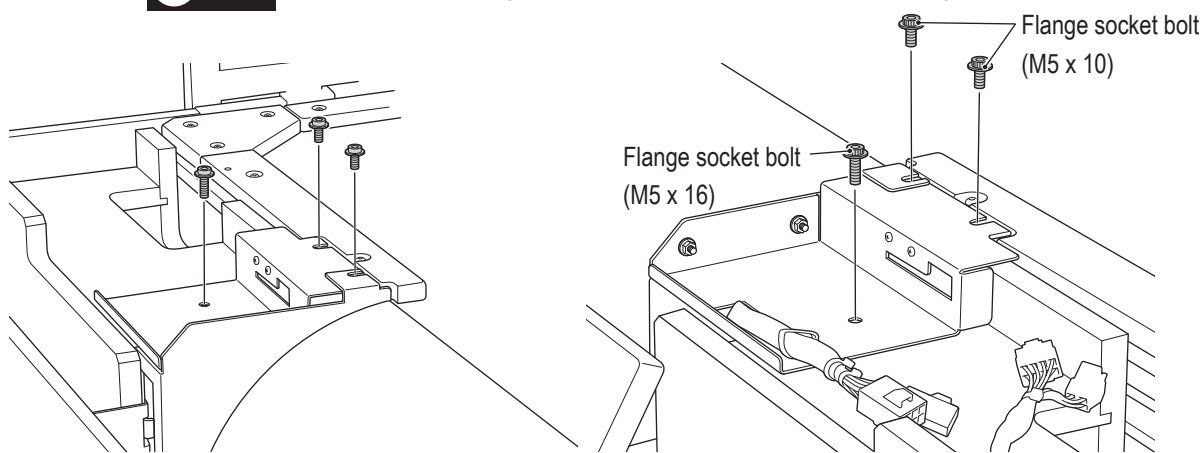

7 Close the goal (L) assembly. (See "7-5-3 Opening and Closing the Goal (L) and (R) Assemblies" on page 38.)

8 Lift the goal (L) assembly straight up with two people, and remove it.

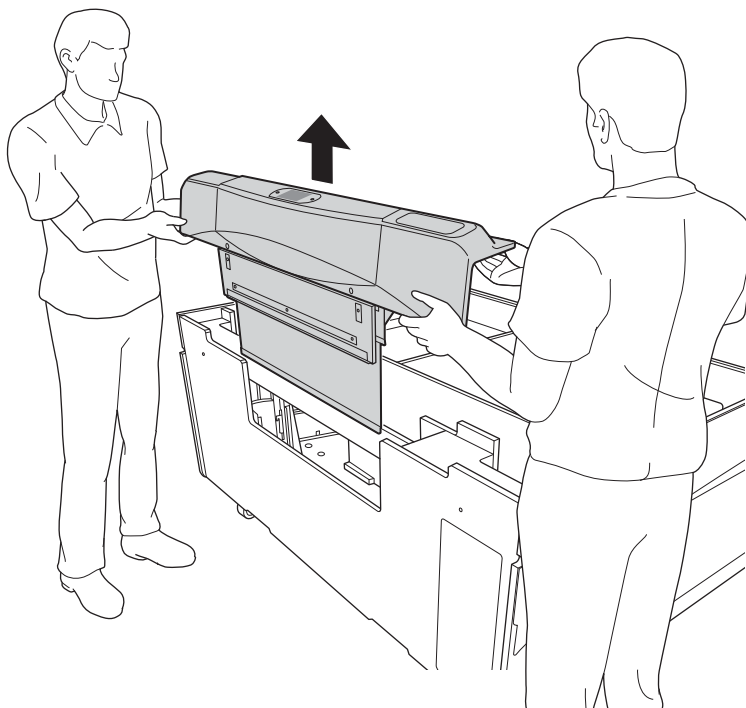

- 1
- 2
- 3
- 4
- 5
- 6
- 7
- 8A
- 8B**
- 9
- 10
- 11
- 12

Removing, Installing and Replacing Assemblies and Parts

Test Mode

Troubleshooting

8B. Service

- Must be performed by a technician -

- 9** To install, perform the procedure in reverse.

(2) Removing and Installing the Rail (L) and (R) Assemblies

 **WARNING**

- To avoid electric shock, accidents or injuries to yourself or other people, or damage to the electronic circuits, be sure to turn off the power switch before starting work.

- 1** Turn off the power switch. (See “7-6-1 Turning the Power Switch On” on page 39.)
- 2** Remove the rail (L) and (R) assemblies by reversing the installation procedure. (See steps **5** to **14** of “8A-2-5 Installing the Side Tower Assembly” on page 96.)

- Must be performed by a technician -

(3) Replacing the Blower Fan

! WARNING

- To avoid electric shock, accidents or injuries to yourself or other people, or damage to the electronic circuits, be sure to turn off the power switch before starting work.

- 1** Turn off the power switch. (See "7-6-1 Turning the Power Switch On" on page 39.)
- 2** Open the front door. (See "8A-5-1 Opening and Closing the Front Doors" on page 107.)
- 3** Disconnect the connector.
- 4** Remove the four flange socket bolts (M5 x 30) and the four flat washers (ø24 for M5).

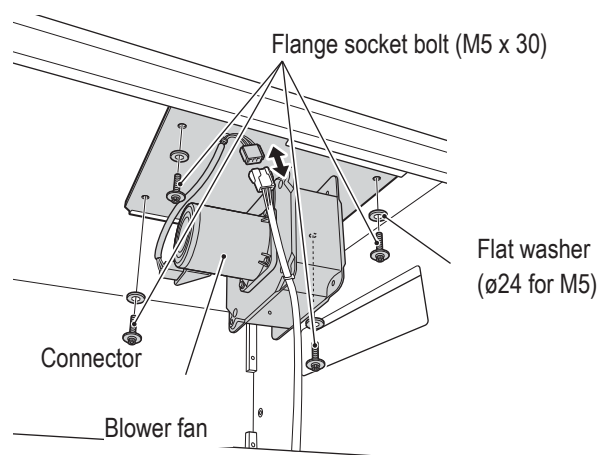

- 5** Slide the blower mounting plate toward the left side, and remove it.

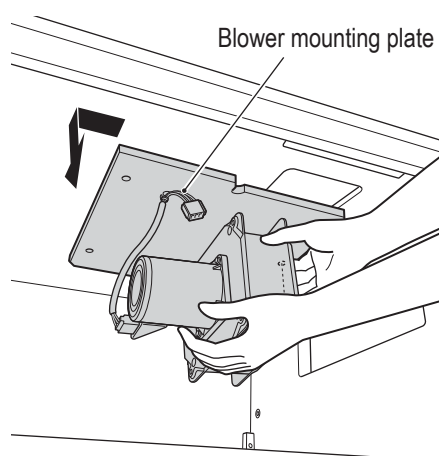

1

2

3

4

5

6

7

8A

8B

9

10

11

12

Removing, Installing and Replacing Assemblies and Parts

Test Mode

Troubleshooting

8B. Service

- Must be performed by a technician -

- 6** Remove the four flange socket bolt (M5 x 16), the four Flat washer($\varnothing 24$ for M5), and remove the blower fan from the blower fan mounting plate.

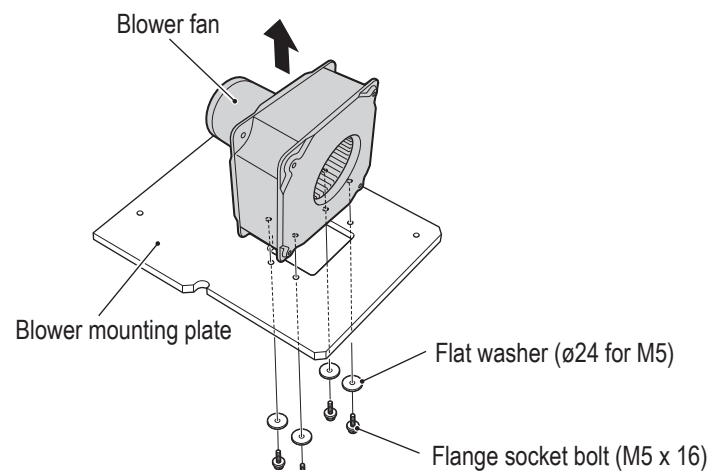

- 7** To install, perform the procedure in reverse.

- Must be performed by a technician -

8B-4-2 Goal (L) and (R) Assemblies

(1) Replacing the Goal (L) and (R) Sensors (Photosensor Side) and (Photo-emitter Side)

The description below explains how to replace the (L) side. Follow the same procedure for replacement of the (R) side.

! WARNING

- To avoid electric shock, accidents or injuries to yourself or other people, or damage to the electronic circuits, be sure to turn off the power switch before starting work.

- 1** Turn off the power switch. (See "7-6-1 Turning the Power Switch On" on page 39.)
- 2** Remove the goal (L) assembly. (See "8B-4-1 (1) Removing and Installing the Goal (L) and (R) Assemblies" on page 136.)
- 3** Disconnect the two connectors of the goal (L) sensor (photosensor side) and (photo-emitter side).

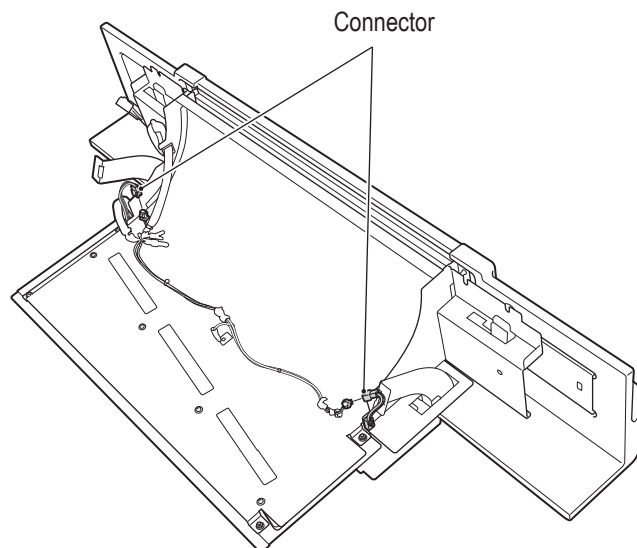

- 4** Remove the two Hex nuts with flange (M3), and remove the goal (L) sensor (photosensor side) and (photo-emitter side).

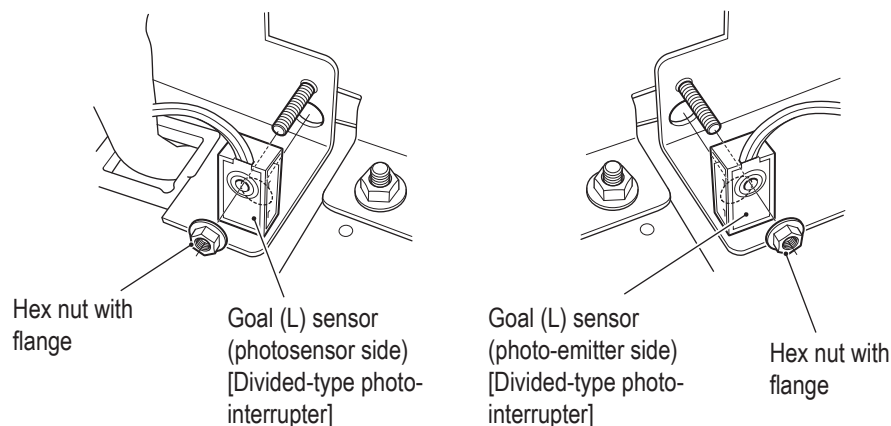

- 5** To install, perform the procedure in reverse.

1

2

3

4

5

6

7

8A

8B

9

10

11

12

Removing, Installing and Replacing Assemblies and Parts

Test Mode

Troubleshooting

- Must be performed by a technician -

8B-4-3 Rail (L) and (R) Assemblies

(1) Replacing the Rail (L) and (R) Sensors (Upper) and (Middle)

The description below explains how to replace the (L) side. Follow the same procedure for replacement of the (R) side.

⚠ WARNING

- To avoid electric shock, accidents or injuries to yourself or other people, or damage to the electronic circuits, be sure to turn off the power switch before starting work.

- 1** Turn off the power switch. (See "7-6-1 Turning the Power Switch On" on page 39.)
- 2** Remove the rail (L) assembly by reversing the installation procedure. (See steps **5** - **9** of "8A-2-5 Installing the Side Tower Assembly" on page 96.)
- 3** Disconnect the two connectors of the rail (L) sensor (upper) and (middle).
- 4** Remove the two Hex nuts with flange (M3), and remove the rail sensor bracket (B).

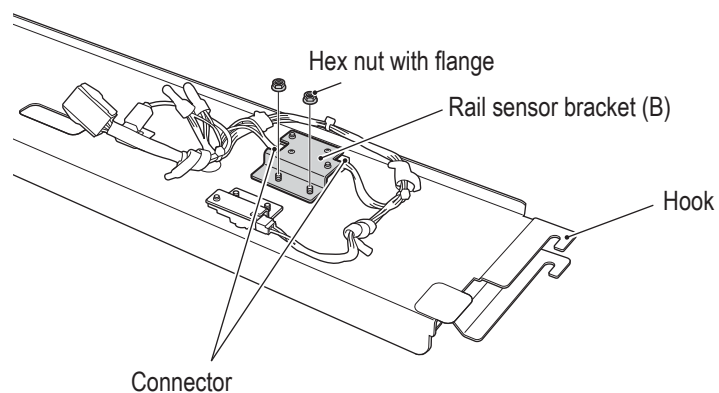



- Must be performed by a technician -

5 Remove the two pan head screws (M3 x 6), and remove the rail (L) sensors (upper) and (middle).

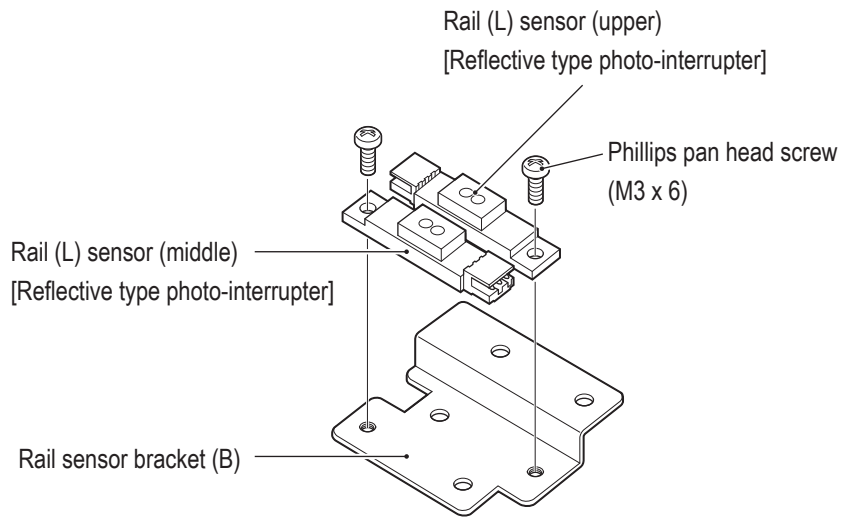

6 To install, perform the procedure in reverse.

- 1
- 2
- 3
- 4
- 5
- 6
- 7
- 8A
- 8B**
- 9
- 10
- 11
- 12

Removing, Installing and Replacing Assemblies and Parts

Test Mode

Troubleshooting

- Must be performed by a technician -

(2) Replacing the Rail (L) and (R) Sensors (Lower)

The description below explains how to replace the (L) side. Follow the same procedure for replacement of the (R) side.

! WARNING

- To avoid electric shock, accidents or injuries to yourself or other people, or damage to the electronic circuits, be sure to turn off the power switch before starting work.

- 1** Turn off the power switch. (See "7-6-1 Turning the Power Switch On" on page 39.)
- 2** Remove the rail (L) assembly. Reverse the installation procedure. (See steps **5** to **9** of "8A-2-5 Installing the Side Tower Assembly" on page 96.)
- 3** Disconnect the connector of the rail (L) sensor (lower).
- 4** Remove the two Hex nuts with flange (M3), and remove the rail sensor bracket (A).

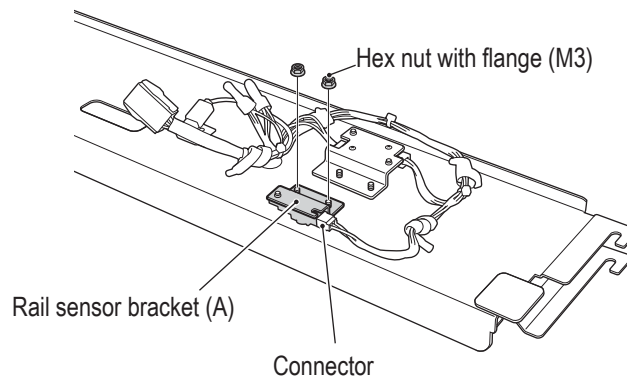

- 5** Remove the pan head screw (M3 x 6), and remove the rail (L) sensor (lower).

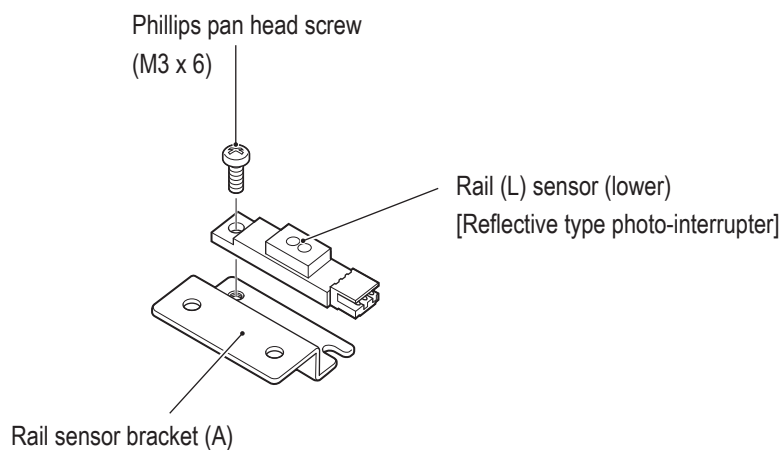

- 6** To install, perform the procedure in reverse.



- Must be performed by a technician -

8B-4-4 Side tower assembly

(1) Removing and Installing the Side Tower Assembly

! WARNING

● To avoid electric shock, accidents or injuries to yourself or other people, or damage to the electronic circuits, be sure to turn off the power switch before starting work.

- 1** Turn off the power switch. (See "7-6-1 Turning the Power Switch On" on page 39.)
- 2** Remove the side tower assembly by reversing the installation procedure. (See steps **2** - **16** of "8A-2-5 Installing the Side Tower Assembly" on page 96.)
- 3** To install, perform the procedure in reverse.

- 1
- 2
- 3
- 4
- 5
- 6
- 7
- 8A
- 8B**
- 9
- 10
- 11
- 12

Removing, Installing and Replacing Assemblies and Parts

Test Mode

Troubleshooting

- Must be performed by a technician -

(2) Replacing the Main PC Board

⚠ WARNING

- To avoid electric shock, accidents or injuries to yourself or other people, or damage to the electronic circuits, be sure to turn off the power switch before starting work.

NOTICE

- PC boards are sensitive to static electricity. If a person handles a PC board while charged with static electricity, the parts on the PC board may be damaged. Before handling a PC board, discharge the static electricity from your body; for example, by touching the surface of grounded metal.

- 1 Turn off the power switch. (See "7-6-1 Turning the Power Switch On" on page 39.)
- 2 Remove the two wing bolts (M5 x 16), disconnect the 15 connectors, and pull out the PCB base.

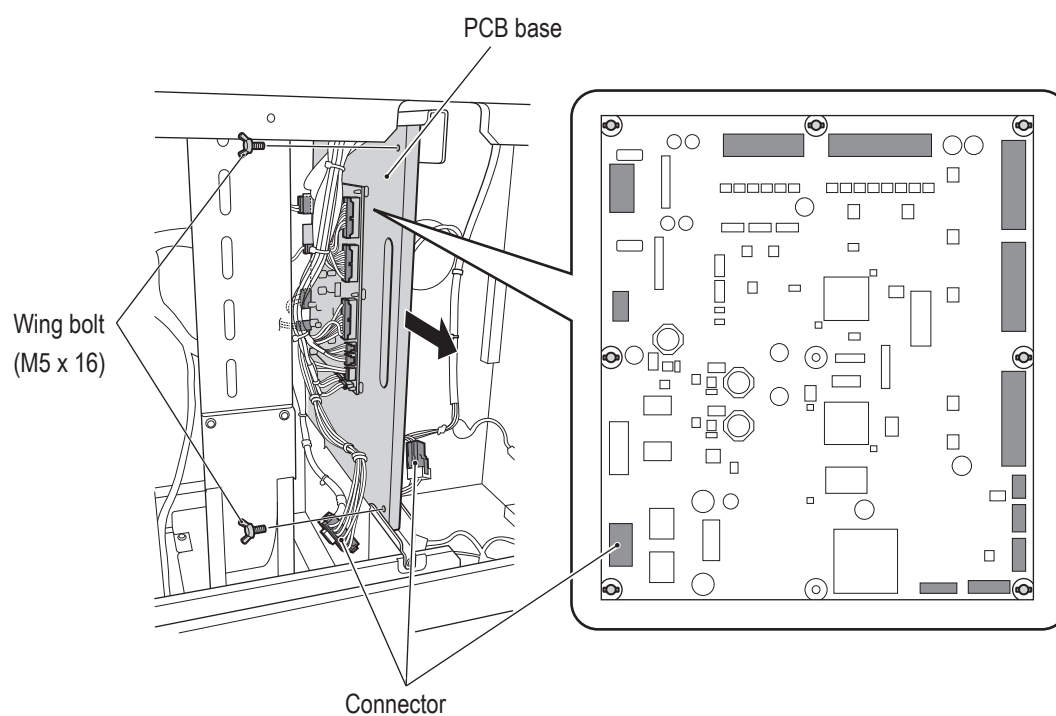



- Must be performed by a technician -

3 Unlock the 7 spacer locks, and replace the main PC board.

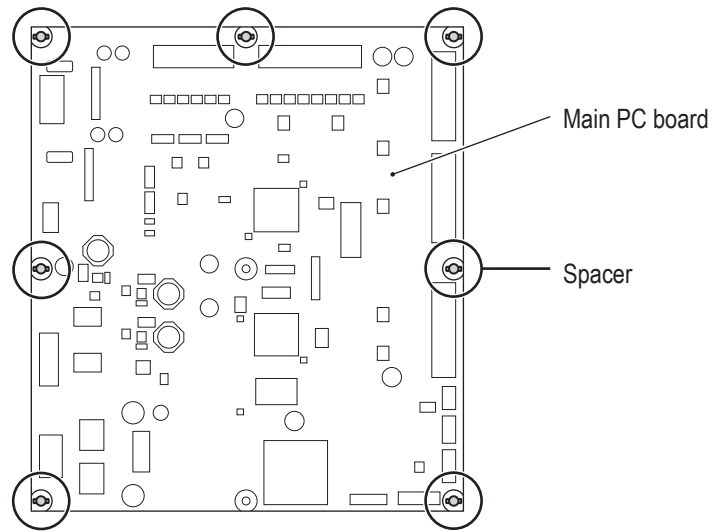

4 To install, perform the procedure in reverse.

- 1
- 2
- 3
- 4
- 5
- 6
- 7
- 8A
- 8B**
- 9
- 10
- 11
- 12

Removing, Installing and Replacing Assemblies and Parts

Test Mode

Troubleshooting

- Must be performed by a technician -

(3) Replacing the Switching Regulator

! WARNING

- To avoid electric shock, accidents or injuries to yourself or other people, or damage to the electronic circuits, be sure to turn off the power switch before starting work.

NOTICE

- PC boards are sensitive to static electricity. If a person handles a PC board while charged with static electricity, the parts on the PC board may be damaged. Before handling a PC board, discharge the static electricity from your body; for example, by touching the surface of grounded metal.

- 1** Turn off the power switch. (See "7-6-1 Turning the Power Switch On" on page 39.)
- 2** Pull out the PCB base. (See "8B-4-4 (2) Replacing the Main PC Board" on page 146.)
- 3** Disconnect the connectors (two in case of 12 V, three in case of 24 V) of the switching regulator to be replaced.

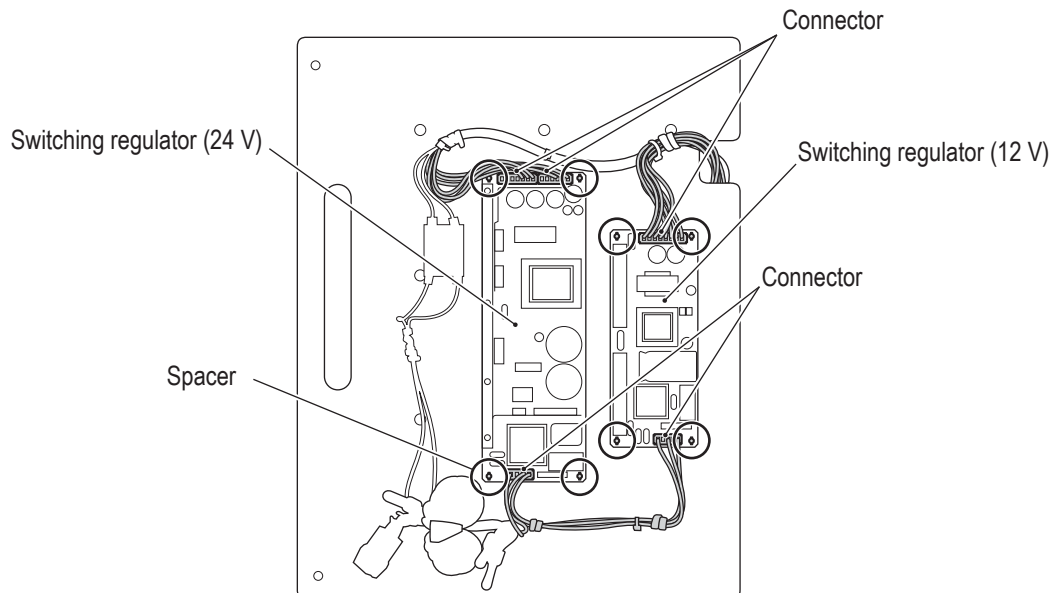

- 4** Unlock the four spacer locks, and replace the switching regulator.
- 5** To install, perform the procedure in reverse.

- Must be performed by a technician -

(4) Replacing the SSR

! WARNING

- To avoid electric shock, accidents or injuries to yourself or other people, or damage to the electronic circuits, be sure to turn off the power switch before starting work.

- 1** Turn off the power switch. (See "7-6-1 Turning the Power Switch On" on page 39.)
- 2** Pull out the PCB base. (See "8B-4-4 (2) Replacing the Main PC Board" on page 146.)
- 3** Disconnect the four Faston terminals.

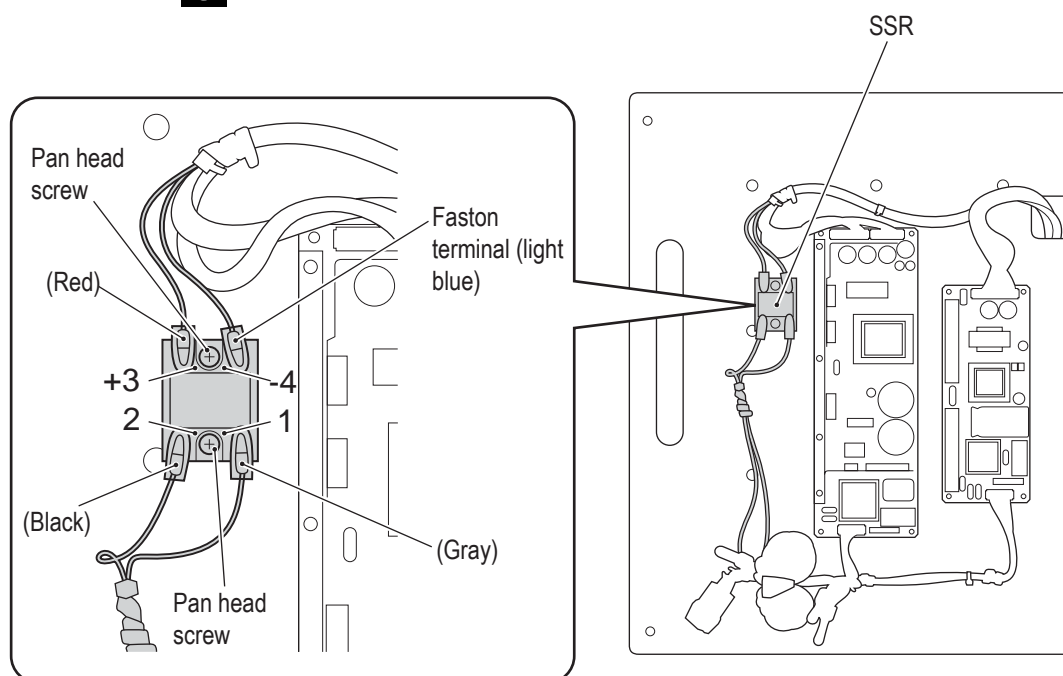

- 4** Remove the two pan head screws (with spring washer) (M4 x 16), and remove the SSR.
- 5** To install, perform the procedure in reverse.

NOTICE

- The SSR has a polarity. The numbers indicated in the figure are marked on the SSR, so be careful and install the SSR with the correct alignment.
- When installing, be careful not to mix up the Faston terminal colors.

1

2

3

4

5

6

7

8A

8B

9

10

11

12

Removing, Installing and Replacing Assemblies and Parts

Test Mode

Troubleshooting

- Must be performed by a technician -

8B-4-5 Hopper assembly

(1) Replacing the L Hopper Motor

! WARNING

- To avoid electric shock, accidents or injuries to yourself or other people, or damage to the electronic circuits, be sure to turn off the power switch before starting work.

- 1** Turn off the power switch. (See "7-6-1 Turning the Power Switch On" on page 39.)
- 2** Remove the side tower assembly by reversing the installation procedure. (See steps **2** - **15** of "8A-2-5 Installing the Side Tower Assembly" on page 96.)
- 3** Remove the wing bolt (M4 x 6), and remove the L hopper cover.

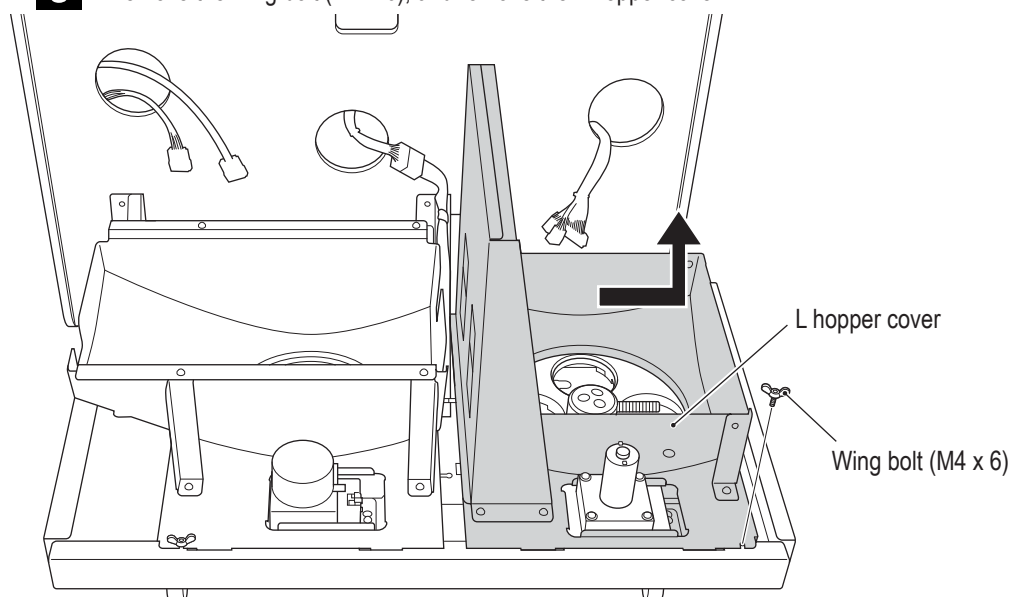

- 4** Remove the cord clip and disconnect the connector.

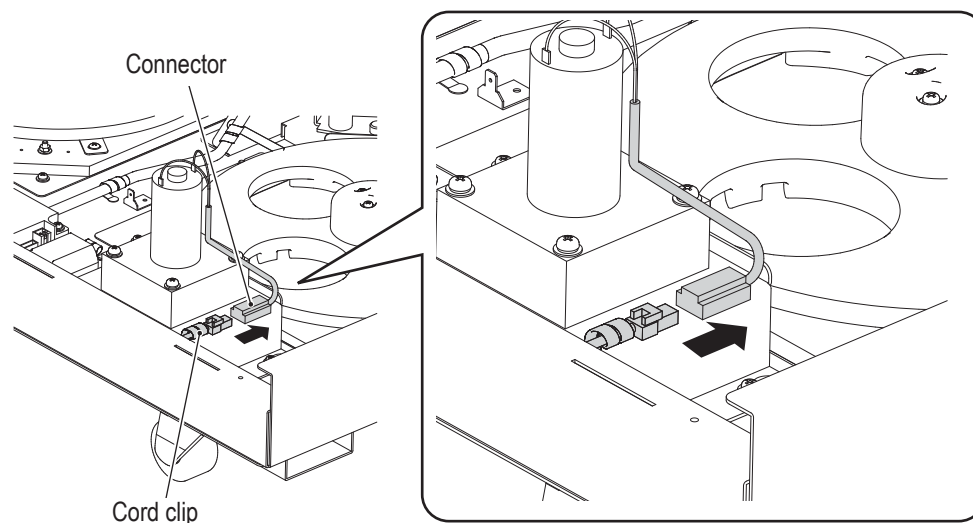

- Must be performed by a technician -

- 5** Loosen the four pan head screws (with flat and spring washers) (M4 x 10), and remove the L hopper motor bracket.

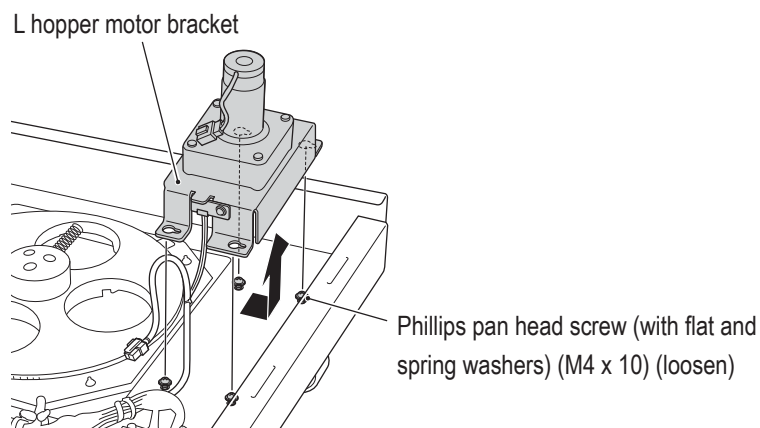

- 6** Disconnect the connector.

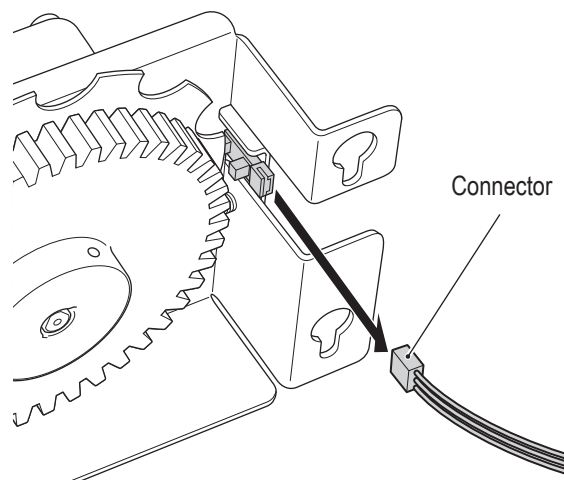

- 7** Remove the encoder bracket. (See the step **3** of "8B-4-5 (2) Replacing the L Hopper Motor Sensor" on page 154.)

- 8** Remove the two double points (M4 x 10), and remove the L hopper gear.

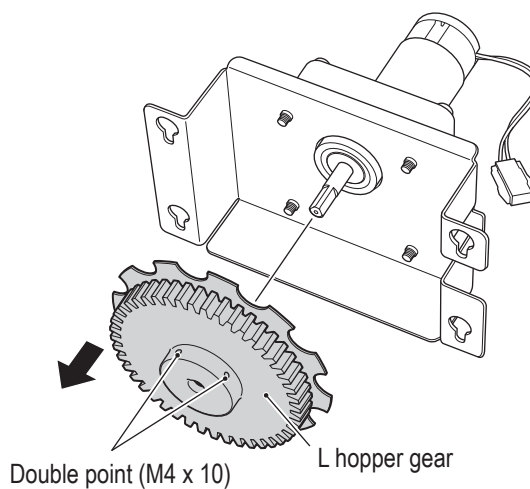

8B. Service

- Must be performed by a technician -

- 9 Remove the four Phillips pan head screws (with flat and spring washers) (M5 x 40), and replace the L hopper motor.

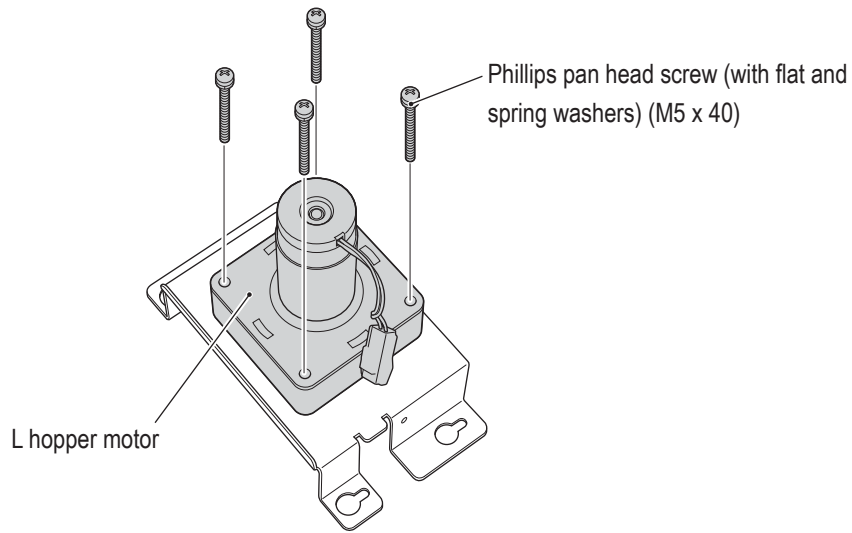

- 10 To install, perform the procedure in reverse.

NOTICE

- When installing, align the lower surface of the hopper gear with the tip of the motor shaft.

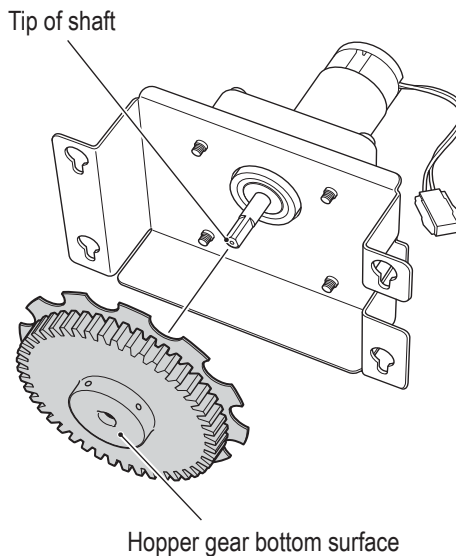

- When installing, install so that the double points are perpendicular to the flat surfaces of the motor shaft.

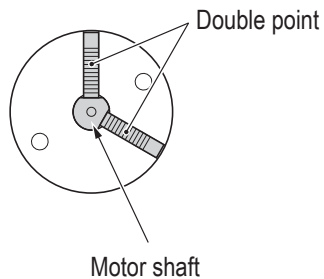

- When installing, press the hopper motor bracket toward the hopper disk so that the hopper gear and hopper disk teeth mesh properly.



8B. Service

- Must be performed by a technician -



- 1
- 2
- 3
- 4
- 5
- 6
- 7
- 8A
- 8B**
- 9
- 10
- 11
- 12

Removing, Installing and Replacing Assemblies and Parts

Test Mode

Troubleshooting

- Must be performed by a technician -

(2) Replacing the L Hopper Motor Sensor

! WARNING

- To avoid electric shock, accidents or injuries to yourself or other people, or damage to the electronic circuits, be sure to turn off the power switch before starting work.

- 1** Turn off the power switch. (See "7-6-1 Turning the Power Switch On" on page 39.)
- 2** Remove the L hopper motor bracket. (See steps **2** - **6** of "8B-4-5 (1) Replacing the L Hopper Motor" on page 150.)
- 3** Remove the Phillips pan head screw (with flat and spring washers) (M4 x 10), and remove the encoder bracket.

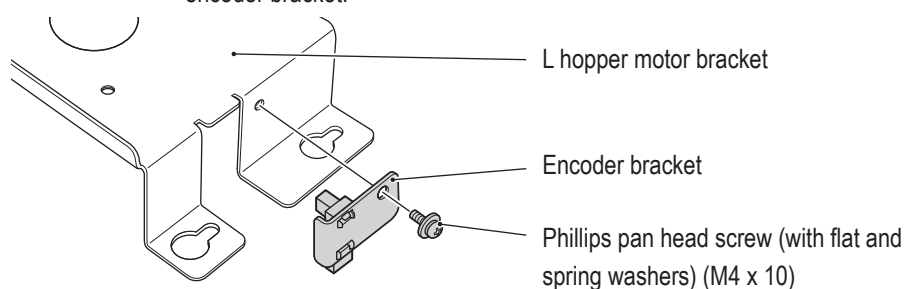

- 4** Release the lock, and replace the L hopper motor sensor.

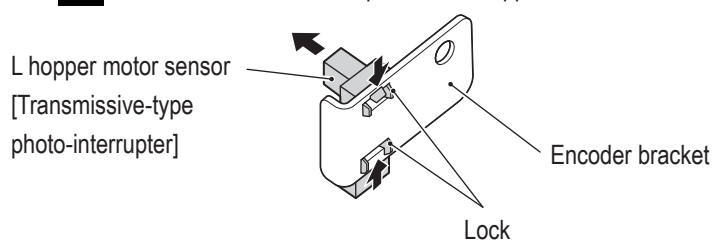

- 5** To install, perform the procedure in reverse.

- Must be performed by a technician -

(3) Replacing the S Hopper Motor

! WARNING

- To avoid electric shock, accidents or injuries to yourself or other people, or damage to the electronic circuits, be sure to turn off the power switch before starting work.

- 1** Turn off the power switch. (See "7-6-1 Turning the Power Switch On" on page 39.)
- 2** Remove the side tower assembly by reversing the installation procedure. (See steps **2** - **15** of "8A-2-5 Installing the Side Tower Assembly" on page 96.)
- 3** Remove the wing bolt (M4 x 6), slide the S hopper cover toward the outside, and remove it.

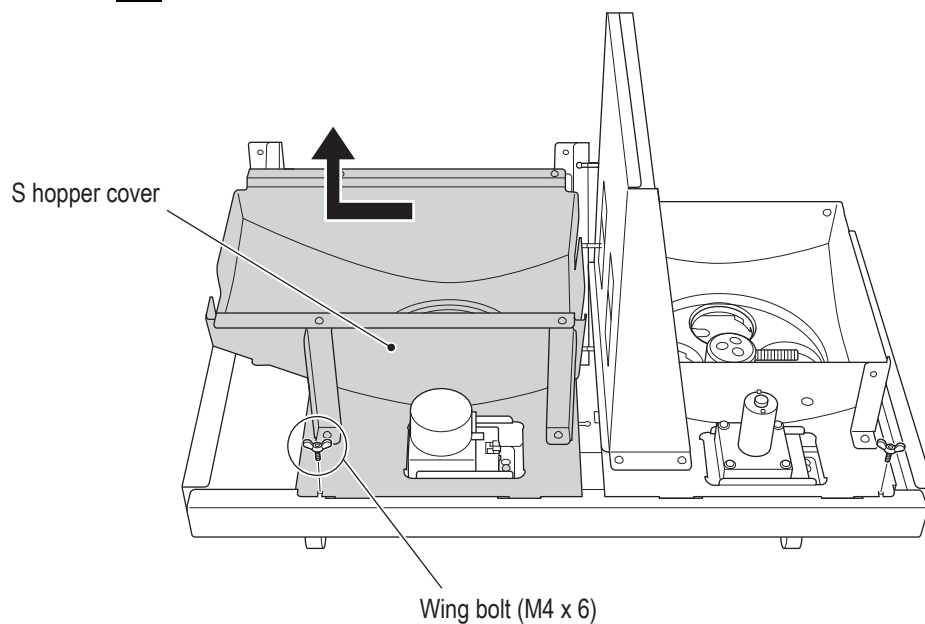

- 4** Remove the cord clip and disconnect the two connectors.
- 5** Loosen the four pan head screws (with flat and spring washers) (M4 x 10), and remove the S hopper motor bracket.

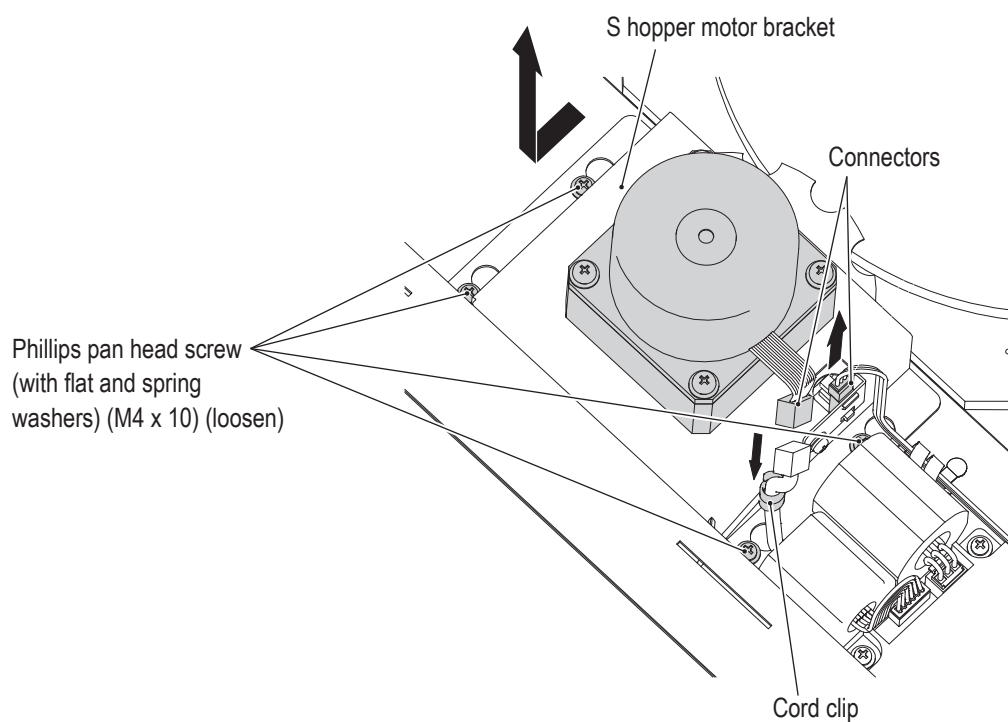

8B. Service

- Must be performed by a technician -

6 Remove the encoder bracket. (See the step **3** of “8B-4-5 (4) Replacing the S Hopper Motor Sensor” on page 158.)

7 Remove the two set screws (M4 x 10), and remove the S hopper gear.

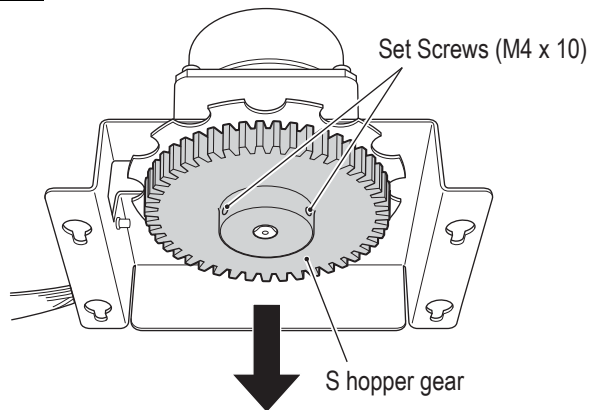

8 Remove the four Phillips pan head screws (with flat and spring washers) (M5 x 8), and replace the S hopper motor.

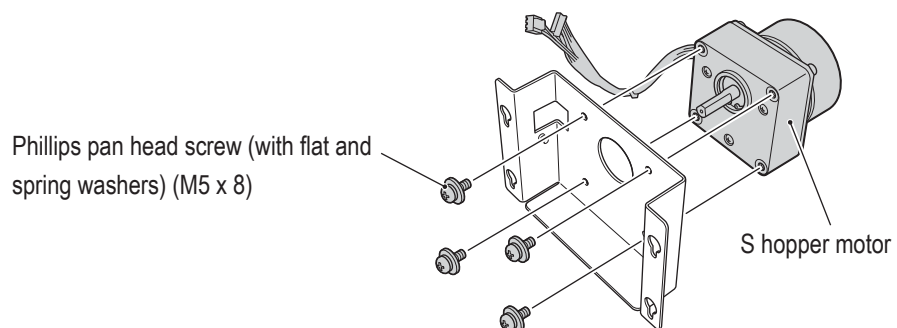



- Must be performed by a technician -

9 To install, perform the procedure in reverse.



- When installing, align the bottom surface of the hopper gear with the tip of the motor shaft.

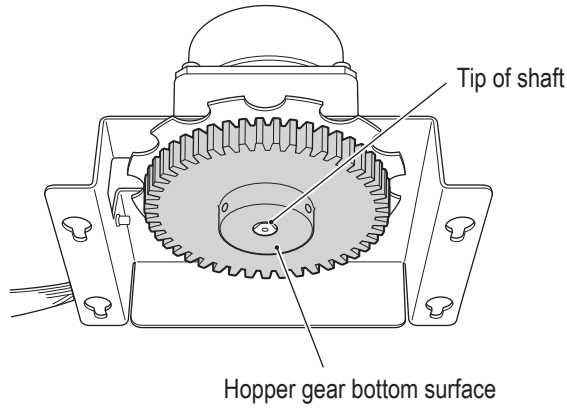

- When installing, install so that the double points are perpendicular to the flat surfaces of the motor shaft.

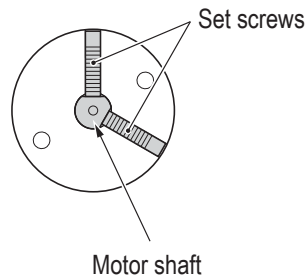

- When installing, press the hopper motor bracket toward the hopper disk so that the hopper gear and hopper disk teeth mesh properly.

- 1
- 2
- 3
- 4
- 5
- 6
- 7
- 8A
- 8B**
- 9
- 10
- 11
- 12

Removing, Installing and Replacing Assemblies and Parts

Test Mode

Troubleshooting

- Must be performed by a technician -

(4) Replacing the S Hopper Motor Sensor

⚠ WARNING

- To avoid electric shock, accidents or injuries to yourself or other people, or damage to the electronic circuits, be sure to turn off the power switch before starting work.

- 1** Turn off the power switch. (See "7-6-1 Turning the Power Switch On" on page 39.)
- 2** Remove the S hopper motor bracket. (See steps **2** - **5** of "8B-4-4 (3) Replacing the S Hopper Motor" on page 155.)
- 3** Remove the Phillips pan head screw (with flat and spring washers) (M4 x 10), and remove the encoder bracket.

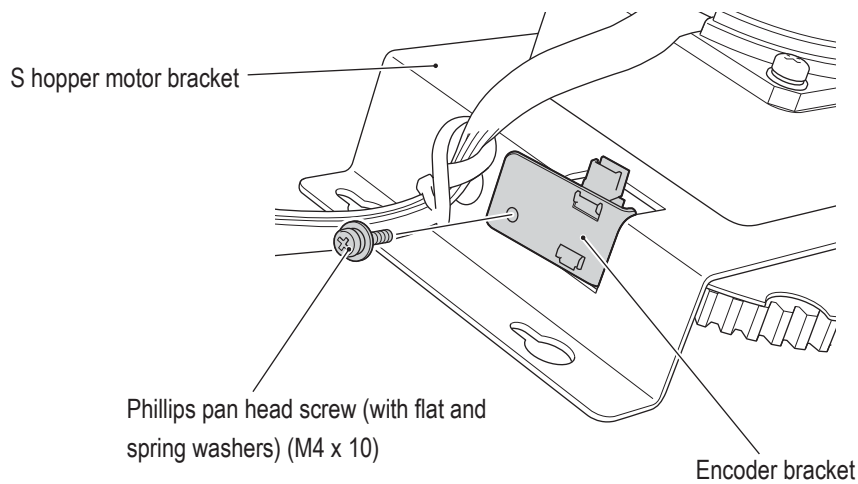

- 4** Release the lock, and replace the S hopper motor sensor.

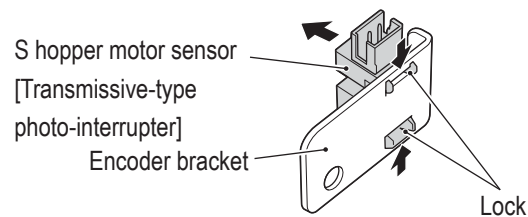

- 5** To install, perform the procedure in reverse.

- Must be performed by a technician -

(5) Replacing the S Hopper Motor Driver PC Board

WARNING

- To avoid electric shock, accidents or injuries to yourself or other people, or damage to the electronic circuits, be sure to turn off the power switch before starting work.

NOTICE

- PC boards are sensitive to static electricity. If a person handles a PC board while charged with static electricity, the parts on the PC board may be damaged. Before handling a PC board, discharge the static electricity from your body; for example, by touching the surface of grounded metal.

- 1** Turn off the power switch. (See "7-6-1 Turning the Power Switch On" on page 39.)
- 2** Remove the side tower assembly by reversing the installation procedure. (See steps **2** - **15** of "8A-2-5 Installing the Side Tower Assembly" on page 96.)
- 3** Remove the one wing bolt (M4 x 6) each, and remove the L hopper cover and the S hopper cover.

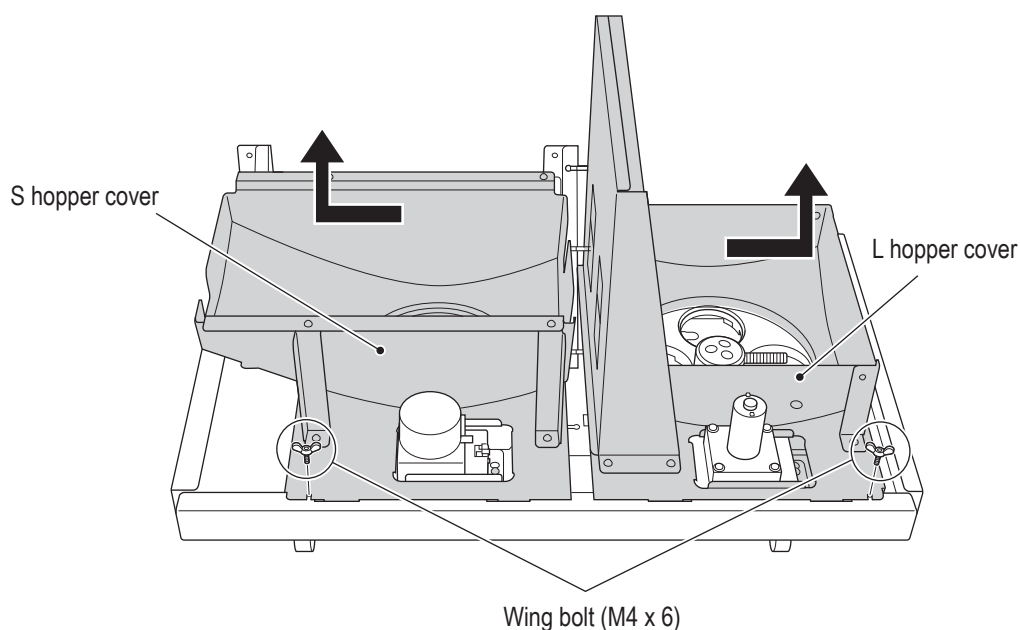

8B. Service

- Must be performed by a technician -

- 4** Disconnect the four connectors, remove the four Phillips pan head screws (with flat and spring washers) (M4 x 25), and replace the S hopper motor driver PC board.

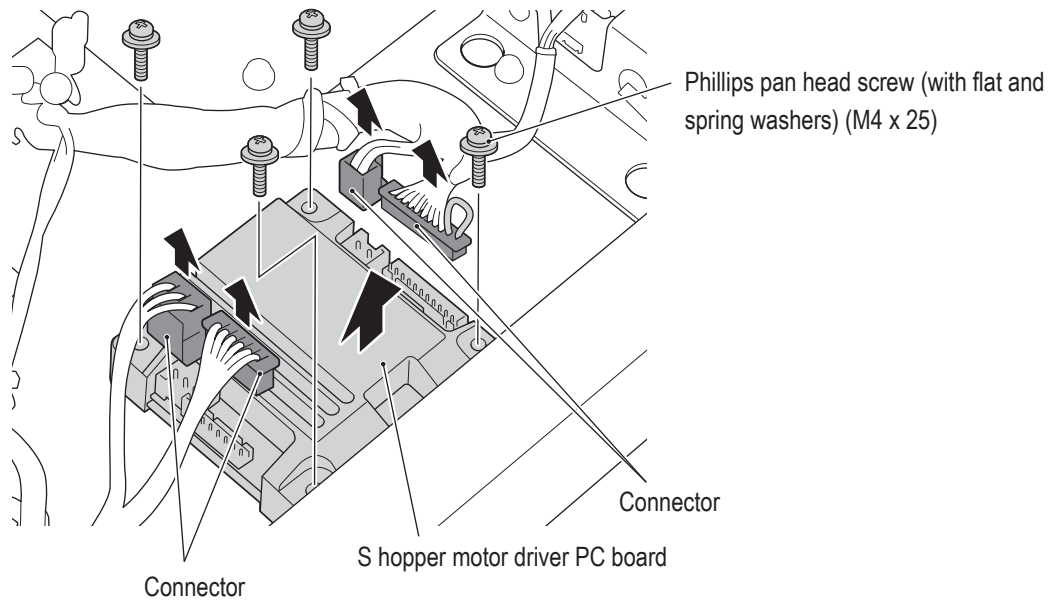

- 5** To install, perform the procedure in reverse.

- Must be performed by a technician -

8B-4-6 Slider Assembly

(1) Replacing the Stopper Solenoids (L) and (R)

The description below explains how to replace the (L) side. Follow the same procedure for replacement of the (R) side.

! WARNING

- To avoid electric shock, accidents or injuries to yourself or other people, or damage to the electronic circuits, be sure to turn off the power switch before starting work.

- 1** Turn off the power switch. (See "7-6-1 Turning the Power Switch On" on page 39.)
- 2** Remove the rear panel. (See "8A-5-3 Opening and Closing the Rear Panel" on page 108.)
- 3** Disconnect the connector, remove the four Hex nuts with flange (M4) and two Phillips pan head screws (with flat and spring washers) (M4 x 10), loosen the two Hex nuts with flange (M4), and remove the L rail (H).

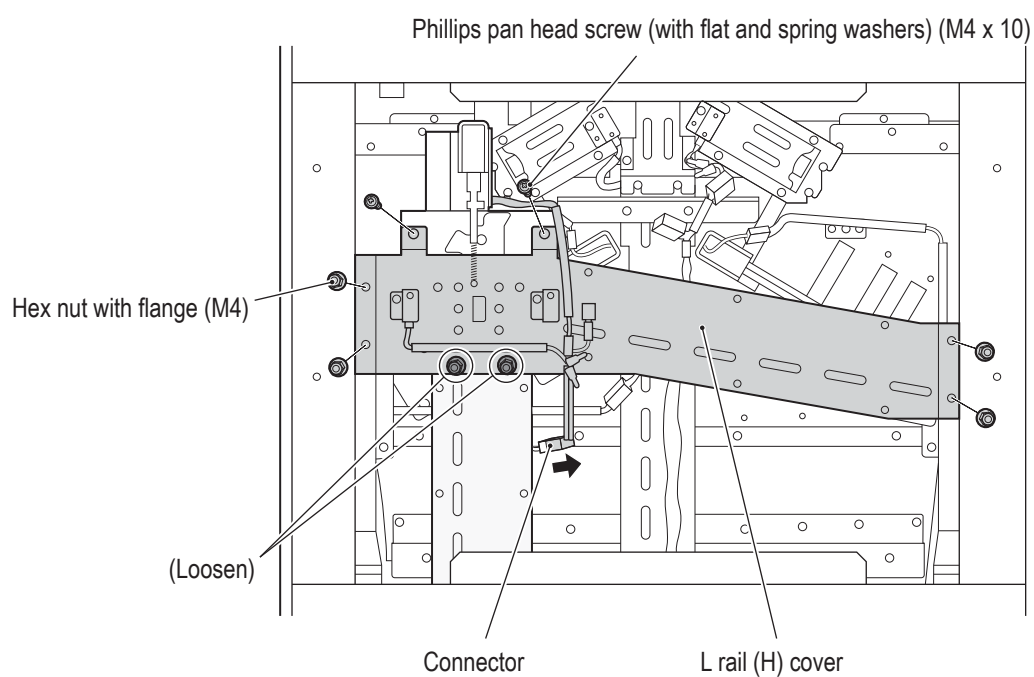

Removing, Installing and Replacing Assemblies and Parts

Test Mode

Troubleshooting

8B. Service

- Must be performed by a technician -

- 4** Disconnect the two connectors, remove the two Hex nuts with flange (M4), and remove the stopper base L.

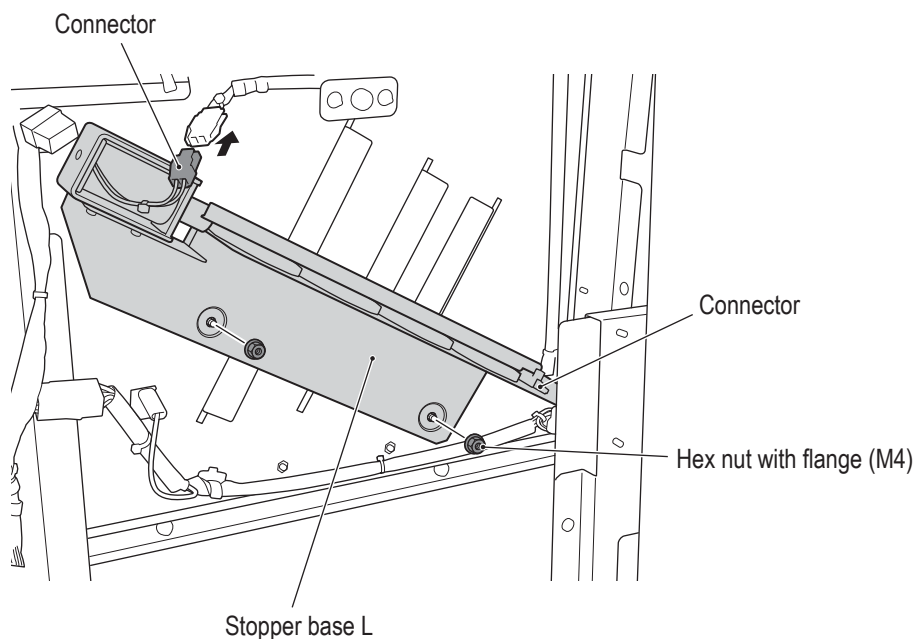

- 5** Remove the four Phillips pan head screw (with flat and spring washers) (M3 x 6), and replace the stopper solenoid.

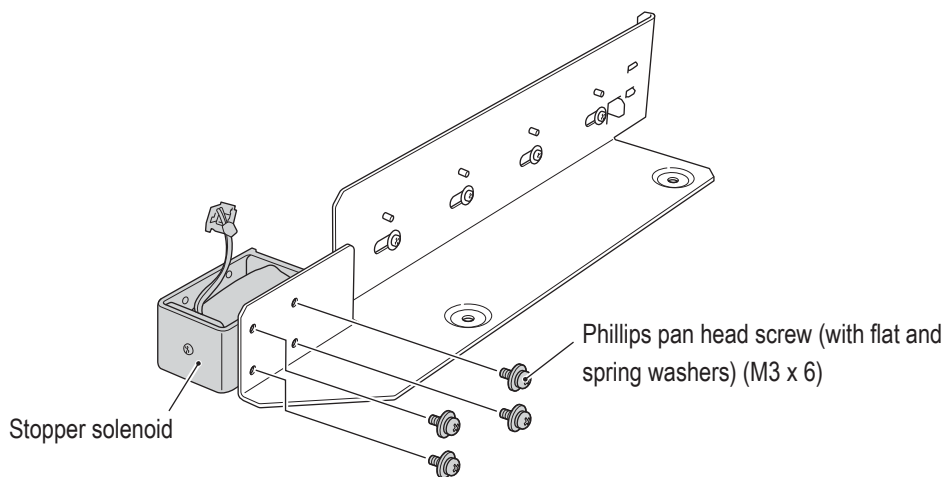

- 6** To install, perform the procedure in reverse.

- Must be performed by a technician -

(2) Replacing the Stopper (L) and (R) Sensors

The description below explains how to replace the (L) side. Follow the same procedure for replacement of the (R) side.

! WARNING

● To avoid electric shock, accidents or injuries to yourself or other people, or damage to the electronic circuits, be sure to turn off the power switch before starting work.

- 1** Turn off the power switch. (See “7-6-1 Turning the Power Switch On” on page 39.)
- 2** Remove the stopper base L. (See steps **2** - **4** of “8B-4-6 (1) Replacing the Stopper Solenoids (L) and (R)” on page 161.)

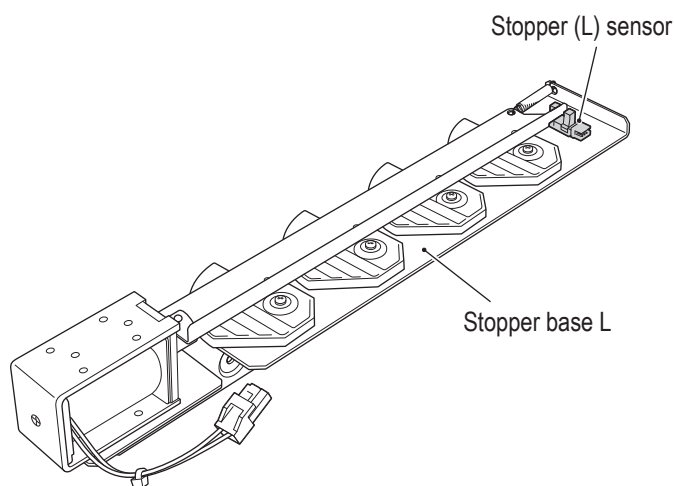

- 3** Release the lock, and replace the stopper (L) sensor.

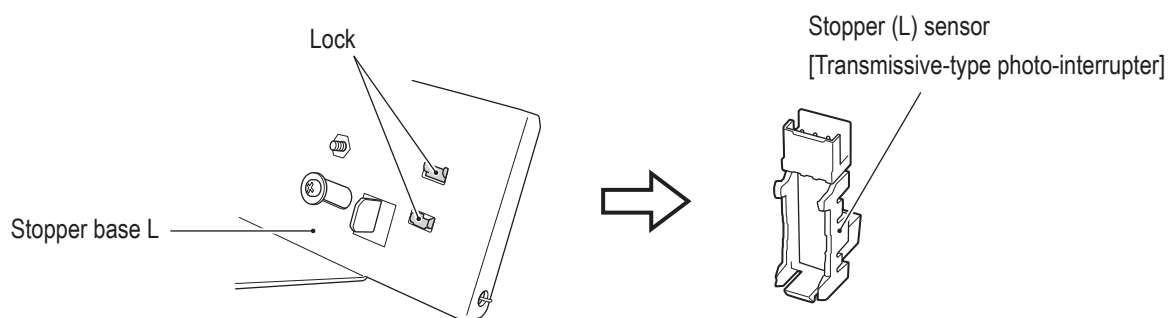

- 4** To install, perform the procedure in reverse.

- 1
- 2
- 3
- 4
- 5
- 6
- 7
- 8A
- 8B**
- 9
- 10
- 11
- 12

Removing, Installing and Replacing Assemblies and Parts

Test Mode

Troubleshooting

- Must be performed by a technician -

8B-4-7 S escalator Assembly

(1) Replacing the S divider (L) and (R) Outlet Sensors

The description below explains how to replace the (L) side. Follow the same procedure for replacement of the (R) side.

! WARNING

- To avoid electric shock, accidents or injuries to yourself or other people, or damage to the electronic circuits, be sure to turn off the power switch before starting work.

- 1** Turn off the power switch. (See "7-6-1 Turning the Power Switch On" on page 39.)
- 2** Remove the rear panel. (See "8A-5-3 Opening and Closing the Rear Panel" on page 108.)
- 3** Disconnect the connector, remove the Hex nuts with flange (M4), and remove the escalator sensor bracket.

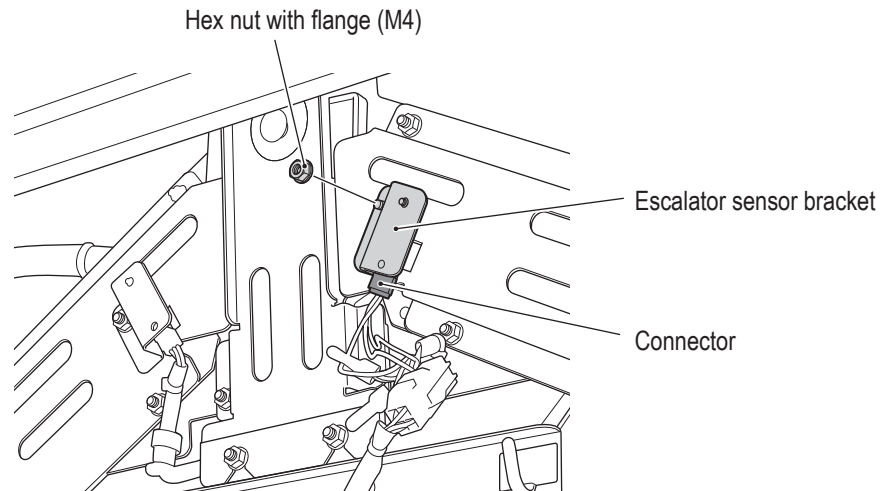

- 4** Remove the Phillips pan head screw (M3 x 6), and replace the S divider (L) outlet sensor.

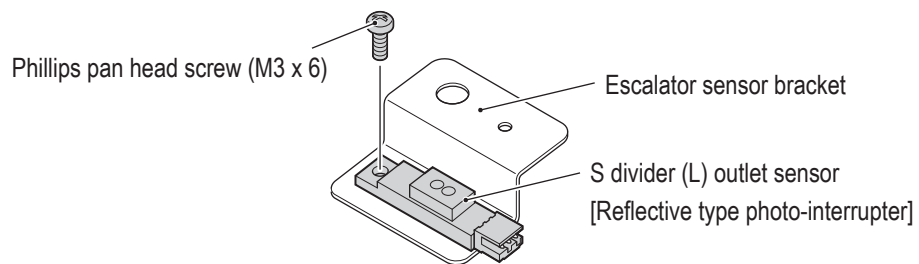

- 5** To install, perform the procedure in reverse.

- Must be performed by a technician -

8B-4-8 L escalator assembly

(1) Replacing the L divider Solenoid

! WARNING

- To avoid electric shock, accidents or injuries to yourself or other people, or damage to the electronic circuits, be sure to turn off the power switch before starting work.

- 1** Turn off the power switch. (See "7-6-1 Turning the Power Switch On" on page 39.)
- 2** Remove the rear panel. (See "8A-5-3 Opening and Closing the Rear Panel" on page 108.)
- 3** Disconnect the connector.

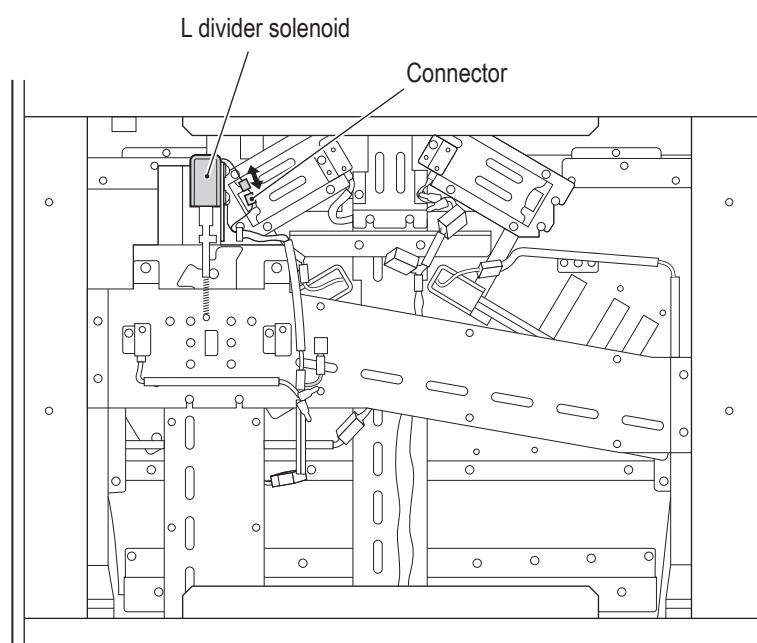

- 4** Remove the four Phillips pan head screws (with flat and spring washers) (M3 x 6), and replace the L divider solenoid.

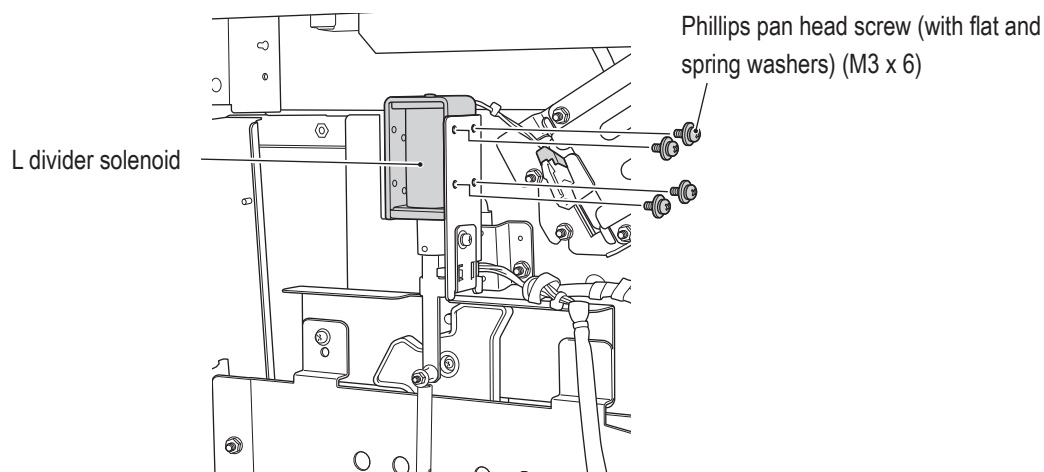

- 5** To install, perform the procedure in reverse.

1

2

3

4

5

6

7

8A

8B

9

10

11

12

Removing, Installing and Replacing Assemblies and Parts

Test Mode

Troubleshooting

- Must be performed by a technician -

(2) Replacing the L divider Sensor

! WARNING

- To avoid electric shock, accidents or injuries to yourself or other people, or damage to the electronic circuits, be sure to turn off the power switch before starting work.

- 1** Turn off the power switch. (See "7-6-1 Turning the Power Switch On" on page 39.)
- 2** Remove the rear panel. (See "8A-5-3 Opening and Closing the Rear Panel" on page 108.)
- 3** Disconnect the connector, remove the Phillips pan head screw (with flat and spring washers) (M4 x 10), and remove the encoder bracket.

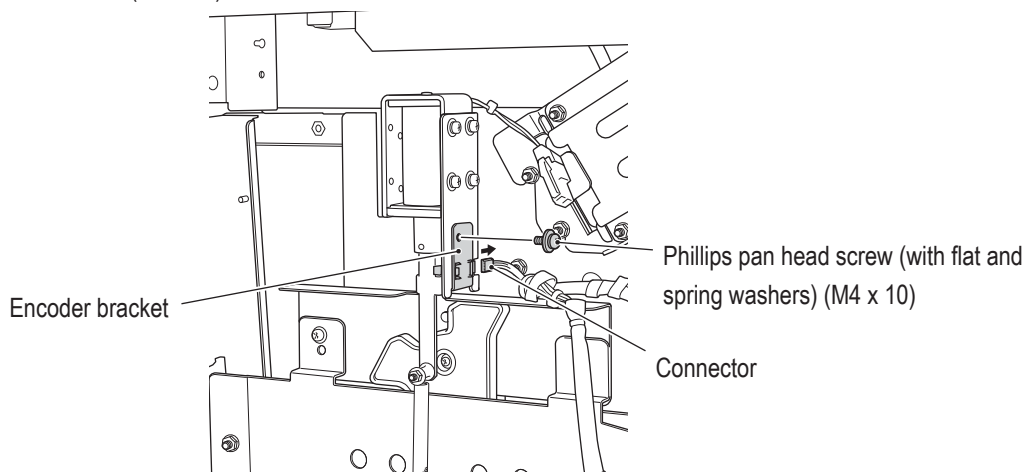

- 4** Release the lock, and replace the L divider sensor.

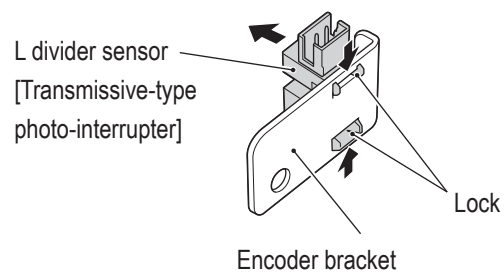

- 5** To install, perform the procedure in reverse.

- Must be performed by a technician -

(3) Replacing the L divider (L) and (R) Outlet Sensors

The description below explains how to replace the (L) side. Follow the same procedure for replacement of the (R) side.

! WARNING

- To avoid electric shock, accidents or injuries to yourself or other people, or damage to the electronic circuits, be sure to turn off the power switch before starting work.

- 1** Turn off the power switch. (See "7-6-1 Turning the Power Switch On" on page 39.)
- 2** Remove the rear panel. (See "8A-5-3 Opening and Closing the Rear Panel" on page 108.)
- 3** Disconnect the connector, remove the Hex nuts with flange (M4), and remove the escalator sensor bracket.

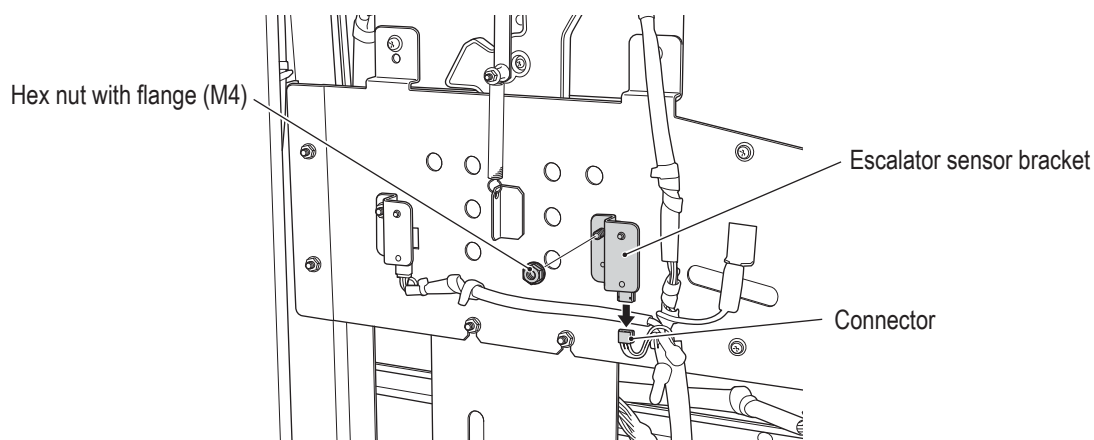

- 4** Remove the Phillips pan head screw (M3 x 6), and replace the L divider (L) outlet sensor.

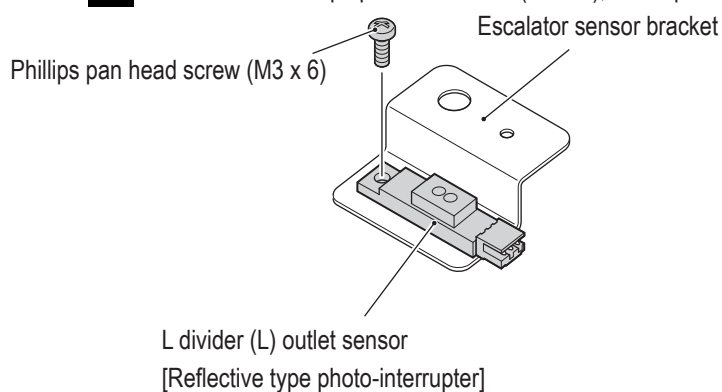

- 5** To install, perform the procedure in reverse.

1

2

3

4

5

6

7

8A

8B

9

10

11

12

Removing, Installing and Replacing Assemblies and Parts

Test Mode

Troubleshooting

- Must be performed by a technician -

8B-4-9 Signboard assembly

(1) Replacing the Time LED (Time LED PC Board)

! WARNING

- To avoid electric shock, accidents or injuries to yourself or other people, or damage to the electronic circuits, be sure to turn off the power switch before starting work.

NOTICE

- PC boards are sensitive to static electricity. If a person handles a PC board while charged with static electricity, the parts on the PC board may be damaged. Before handling a PC board, discharge the static electricity from your body; for example, by touching the surface of grounded metal.

- 1 Turn off the power switch. (See “7-6-1 Turning the Power Switch On” on page 39.)
- 2 Remove the side tower assembly by reversing the installation procedure. (See steps **2 - 15** of “8A-2-5 Installing the Side Tower Assembly” on page 96.)
- 3 Remove the eight Torx bolts (M5 x 12), and remove the signboard.

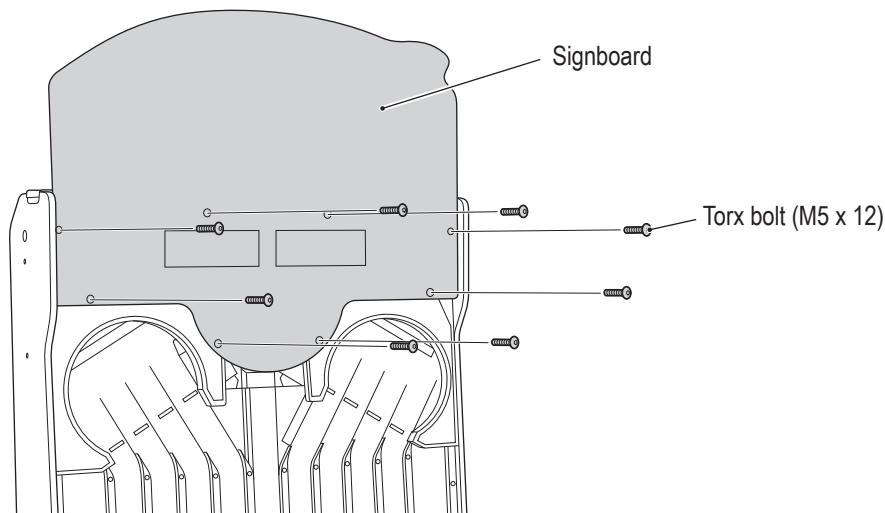

- 4 Disconnect the connector, remove the five Phillips pan head screws (with flat and spring washers) (M4 x 10), and replace the time LED (time LED PC board).

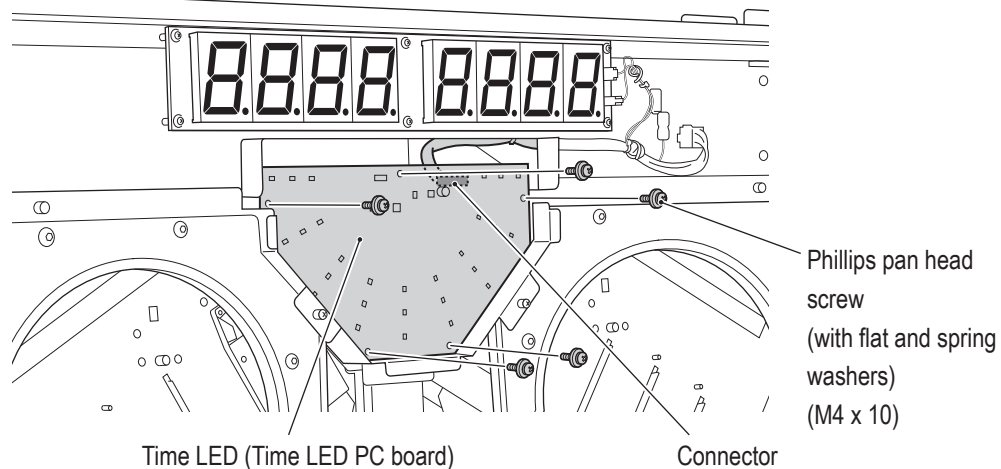

- Must be performed by a technician -

- 5** To install, perform the procedure in reverse.

(2) Replacing the Score LED (Score LED PC Board)

! WARNING

- To avoid electric shock, accidents or injuries to yourself or other people, or damage to the electronic circuits, be sure to turn off the power switch before starting work.

NOTICE

- PC boards are sensitive to static electricity. If a person handles a PC board while charged with static electricity, the parts on the PC board may be damaged. Before handling a PC board, discharge the static electricity from your body; for example, by touching the surface of grounded metal.

- 1** Turn off the power switch. (See "7-6-1 Turning the Power Switch On" on page 39.)
- 2** Remove the side tower assembly by reversing the installation procedure. (See steps **2** - **15** of "8A-2-5 Installing the Side Tower Assembly" on page 96.)
- 3** Disconnect the two connectors, remove the six Phillips pan head screws (with flat and spring washers) (M4 x 10), and replace the score LED (score LED PC board).

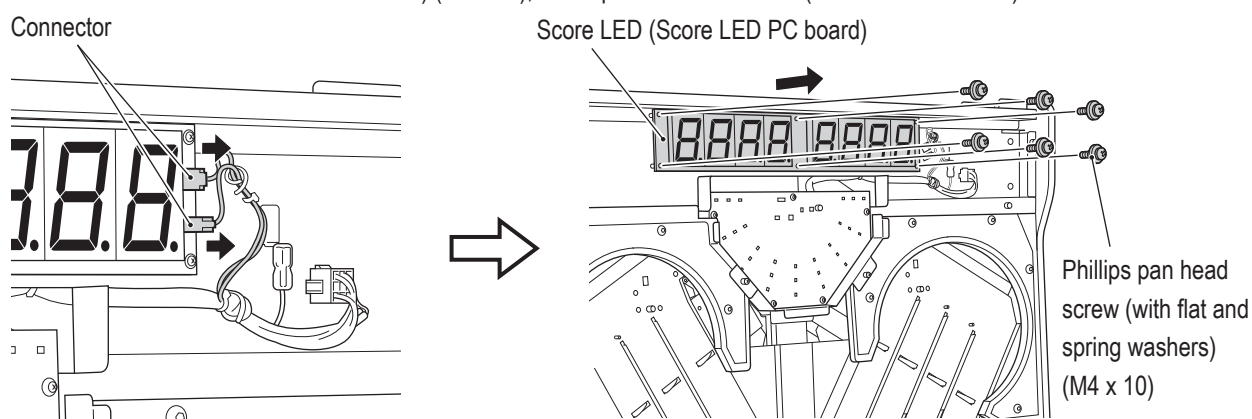

- 4** To install, perform the procedure in reverse.

- Must be performed by a technician -

8B-4-10 Illuminator assembly

(1) Replacing the Circle LED

The description below explains how to replace the L side. Follow the same procedure for replacement of the R side.

WARNING

- To avoid electric shock, accidents or injuries to yourself or other people, or damage to the electronic circuits, be sure to turn off the power switch before starting work.

NOTICE

- PC boards are sensitive to static electricity. If a person handles a PC board while charged with static electricity, the parts on the PC board may be damaged. Before handling a PC board, discharge the static electricity from your body; for example, by touching the surface of grounded metal.
 - When installing, be careful not to pinch the harnesses and connectors.
- 1** Turn off the power switch. (See “7-6-1 Turning the Power Switch On” on page 39.)
 - 2** Remove the side tower assembly by reversing the installation procedure. (See steps **2** - **15** of “8A-2-5 Installing the Side Tower Assembly” on page 96.)
 - 3** Remove the rear panel. (See “8A-5-3 Opening and Closing the Rear Panel” on page 108.)



- Must be performed by a technician -

- 4** Disconnect the connector, and remove the Phillips pan head screw (with flat and spring washers) (M4 x 10).

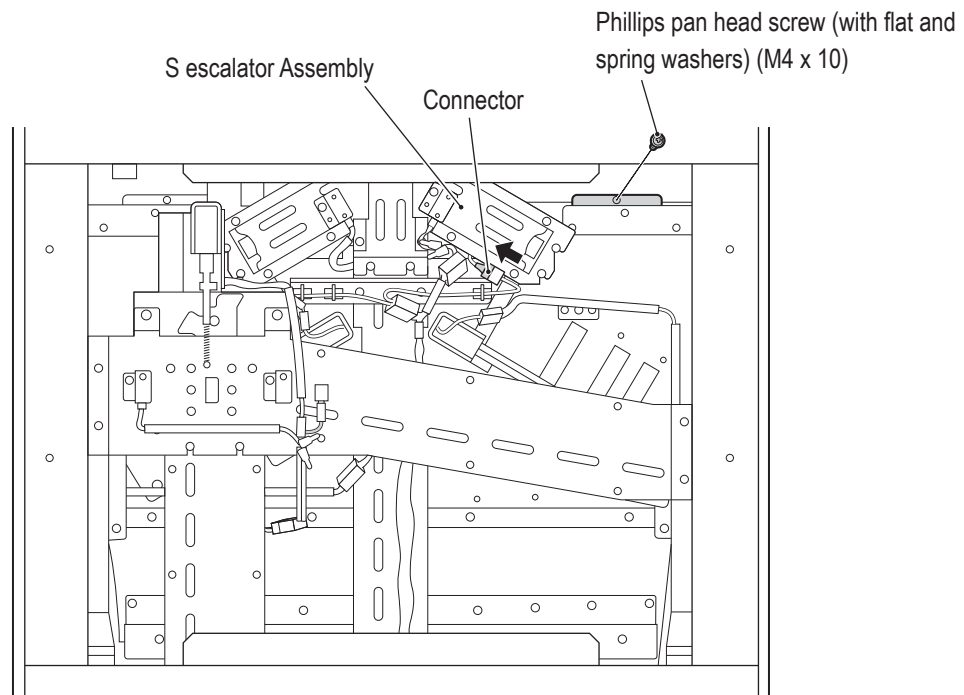

- 5** Remove the five Torx bolts (M5 x 25), and remove the illumination place (L) and illumination base plate (L).

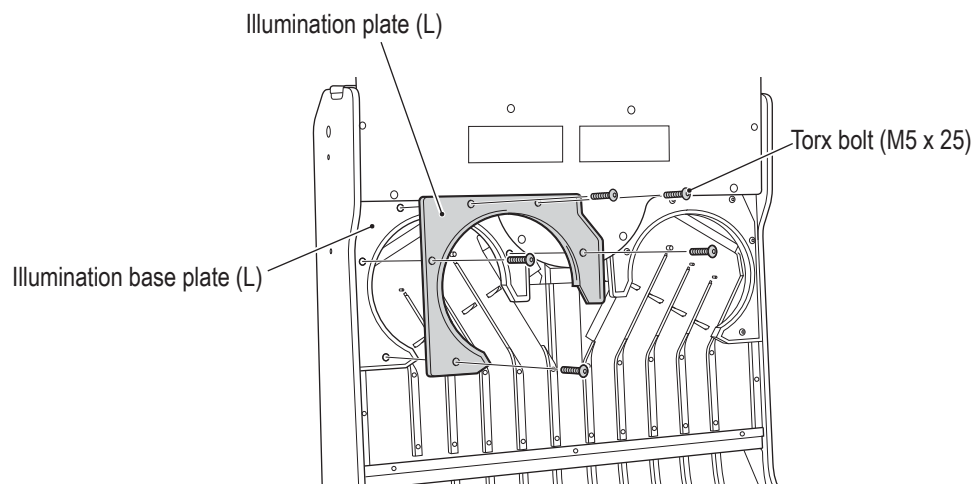

- 1
- 2
- 3
- 4
- 5
- 6
- 7
- 8A
- 8B**
- 9
- 10
- 11
- 12

Removing, Installing and Replacing Assemblies and Parts

Test Mode

Troubleshooting

8B. Service

- Must be performed by a technician -

- 6 Remove the four Phillips countersunk wood screws (3.1 x 8), and remove the illumination base plate.

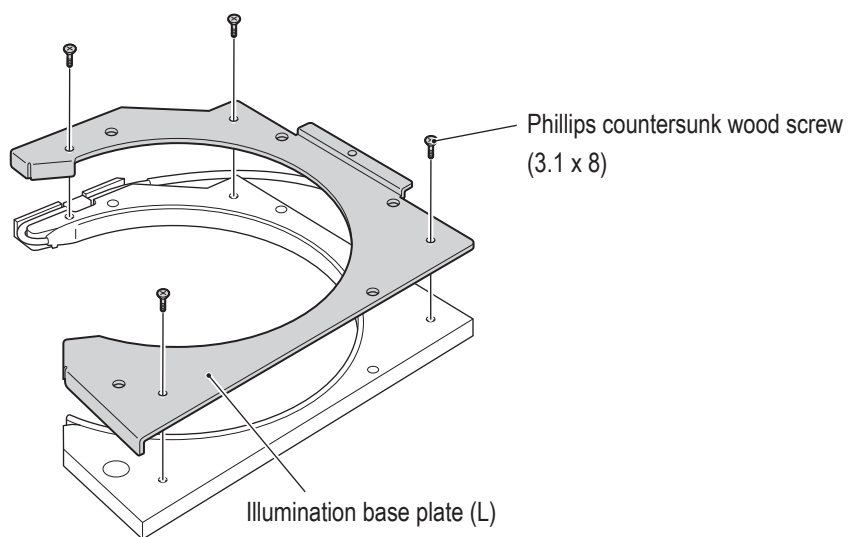

- 7 Disconnect the connector, and remove the circle LED.

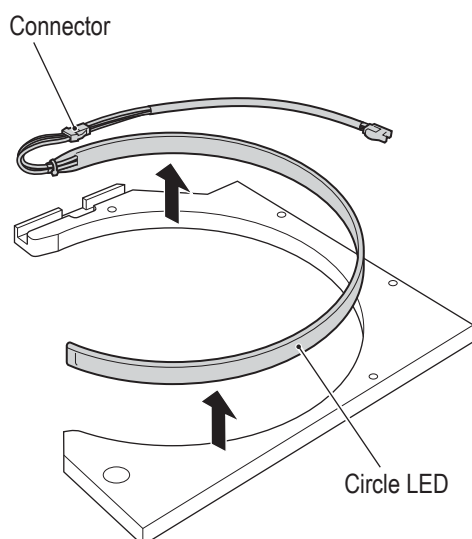

- 8 To install, perform the procedure in reverse.



- Must be performed by a technician -

8B-4-11 Replacing the LED Fluorescent Light

- 1** Remove the side tower assembly. (See the side tower assembly installation procedure.)
- 2** Remove the light frame unit. (See the light assembly installation procedure.)
- 3** Remove the five Phillips truss head machine screws (M4 x 10), and remove the two light cover retainers and the light cover.

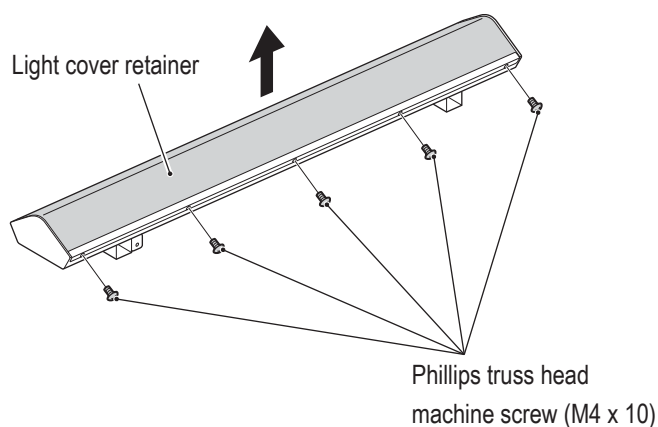

- 4** Replace the LED fluorescent light.

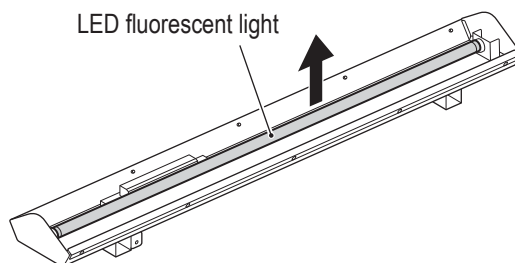

● Use only the specified LED fluorescent light.

- 1
- 2
- 3
- 4
- 5
- 6
- 7
- 8A
- 8B**
- 9
- 10
- 11
- 12

Removing, Installing and Replacing Assemblies and Parts

Test Mode

Troubleshooting

9. Disposal

WARNING

- When disposing of the machine, follow the applicable regulations for collection, transportation and disposal.
- When delegating the collection, transportation and disposal of the machine, be sure to delegate to specialists in each field.



- 1
- 2
- 3
- 4
- 5
- 6
- 7
- 8A
- 8B
- 9**
- 10
- 11
- 12

Disposal

Test Mode

Troubleshooting

10. Parts List

10-1 Overall

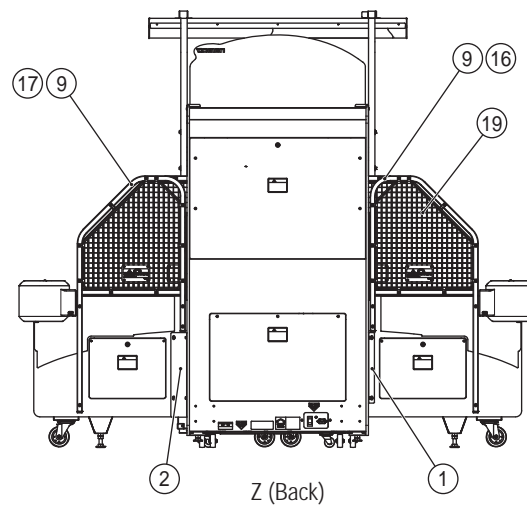
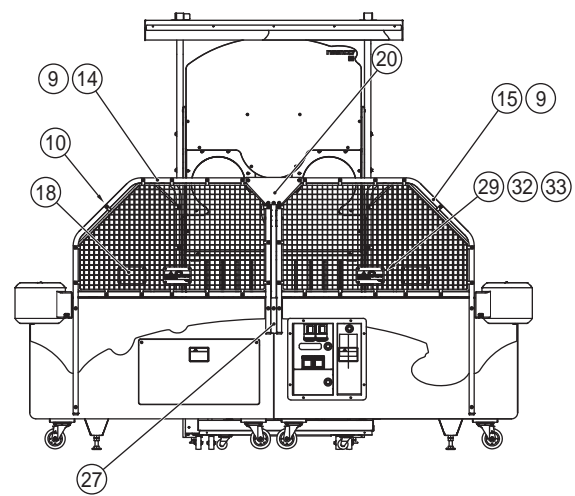
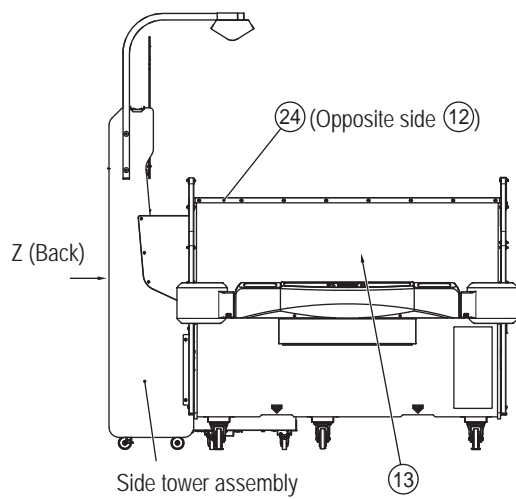
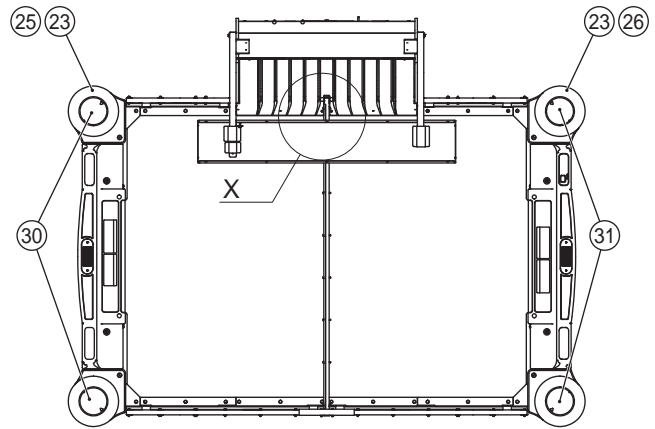
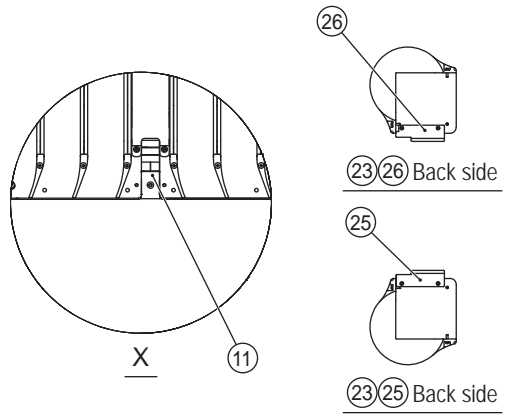

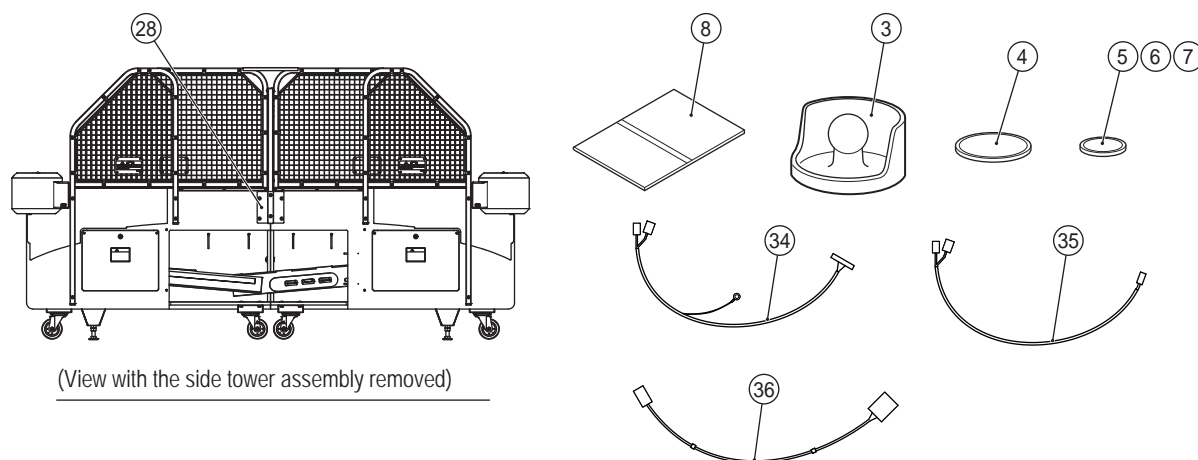

(View with the side tower assembly removed)

No.	Name	Qty.	Type and rating	Part No.
1	Side tower bracket (L)	1		PM10-15513-00
2	Side tower bracket (R)	1		PM10-15514-00
3	Mallet	4		PM90-15505-00
4	Big puck	100	(1 set: 10 pucks)	PM95-15479-00
5	Mini puck (green)	100	1 set: 60 pucks (20 pucks of each color)	PM95-15485-00
6	Mini puck (pink)	100		
7	Mini puck (orange)	100		
8	Operation Manual (English)	1		PM45-15507-00
9	Pipe cap	8		PM90-15740-00
10	Net fixing bracket	50		PM10-15480-00
11	Bumper SS	1		PM10-15515-00
12	Center guard frame	1		PM10-15516-00
13	Center guard	1		PM10-15481-00
14	Net L frame (L)	1		PM10-15517-00
15	Net L frame (R)	1		PM10-15518-00
16	Net S frame (L)	1		PM10-15519-00
17	Net S frame (R)	1		PM10-15520-00
18	Net L	2		PM97-15482-00
19	Net S	2		PM97-15483-00
20	Triangle bracket	1		PM10-15521-00
23	Corner cover	4		PM90-15484-00
24	Center guard retainer	1		PM10-15522-00
25	Corner cover bracket (L)	2		PM10-15523-00
26	Corner cover bracket (R)	2		PM10-15524-00
27	Center guard bracket A	1		PM10-15525-00
28	Center guard bracket B	1		PM10-15526-00
29	Sticker plate	4		PM10-15527-00
30	Stand sticker (red) EXP	2		PM40-15717-00
31	Stand sticker (blue) EXP	2		PM40-15716-00
32	Caution sticker Do Not Approach Net EXP	4		PM40-15698-00
33	Tie-wrap (1,000)	18	CONVEX CV-100N	007-143
34	CASHFLOW selector option cable	1		PM50-15758-00
35	CASHFLOW counter option cable	1		PM50-15758-01
36	Ticket dispenser option cable	2		PM50-15758-02

1

2

3

4

5

6

7

8A

8B

9

10

11

12

Overall

Test Mode

Troubleshooting



10-2 Table top assembly

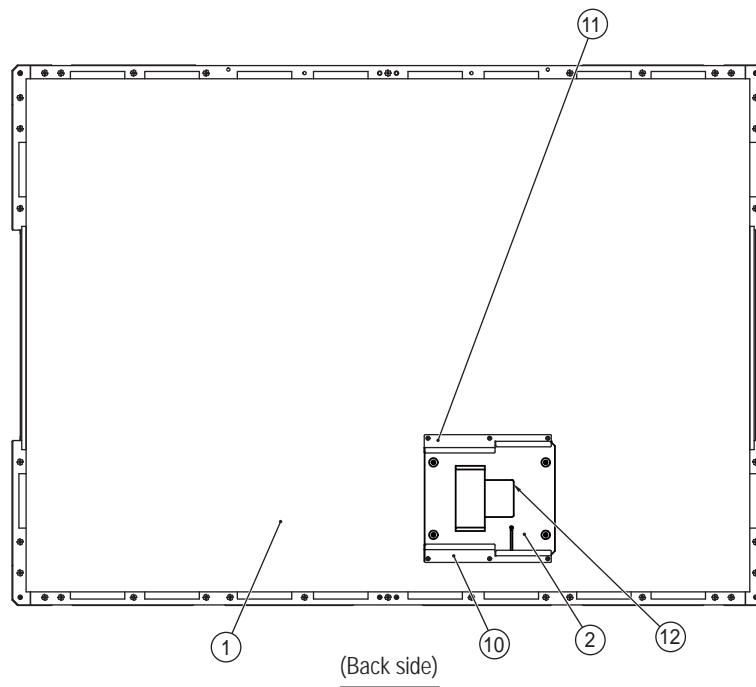
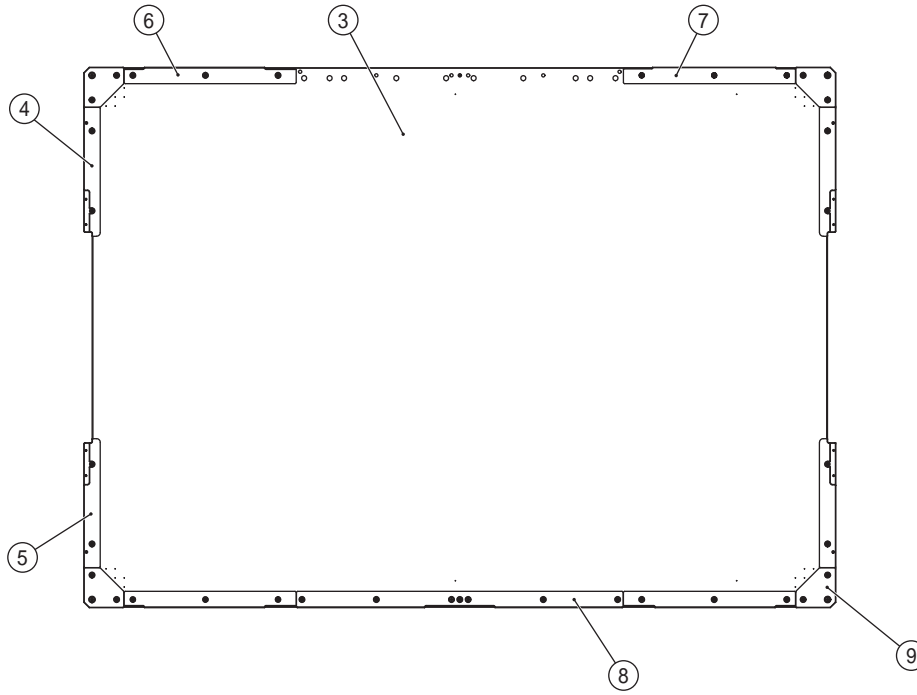

10. Parts List

No.	Name	Qty.	Type and rating	Part No.
1	Air chamber	1		PM63-15730-13
2	Blower mounting plate	1		PM63-15730-14
3	Field (PAC)	1		PM40-15703-00
4	Goal bumper (L)	2		PM10-15639-00
5	Goal bumper (R)	2		PM10-15640-00
6	Bumper S (L)	2		PM10-15641-00
7	Bumper S (R)	2		PM10-15642-00
8	Bumper L	1		PM10-15643-00
9	Corner bumper	4		PM10-15644-00
10	Blower bracket (L)	1		PM10-15645-00
11	Blower bracket (R)	1		PM10-15646-00
12	Blower fan	1	MBS20-BHL	PM55-15725-00

- 1
- 2
- 3
- 4
- 5
- 6
- 7
- 8A
- 8B
- 9
- 10
- 11
- 12

Table top assembly

Test Mode

Troubleshooting

10-3 Cabinet (L) assembly

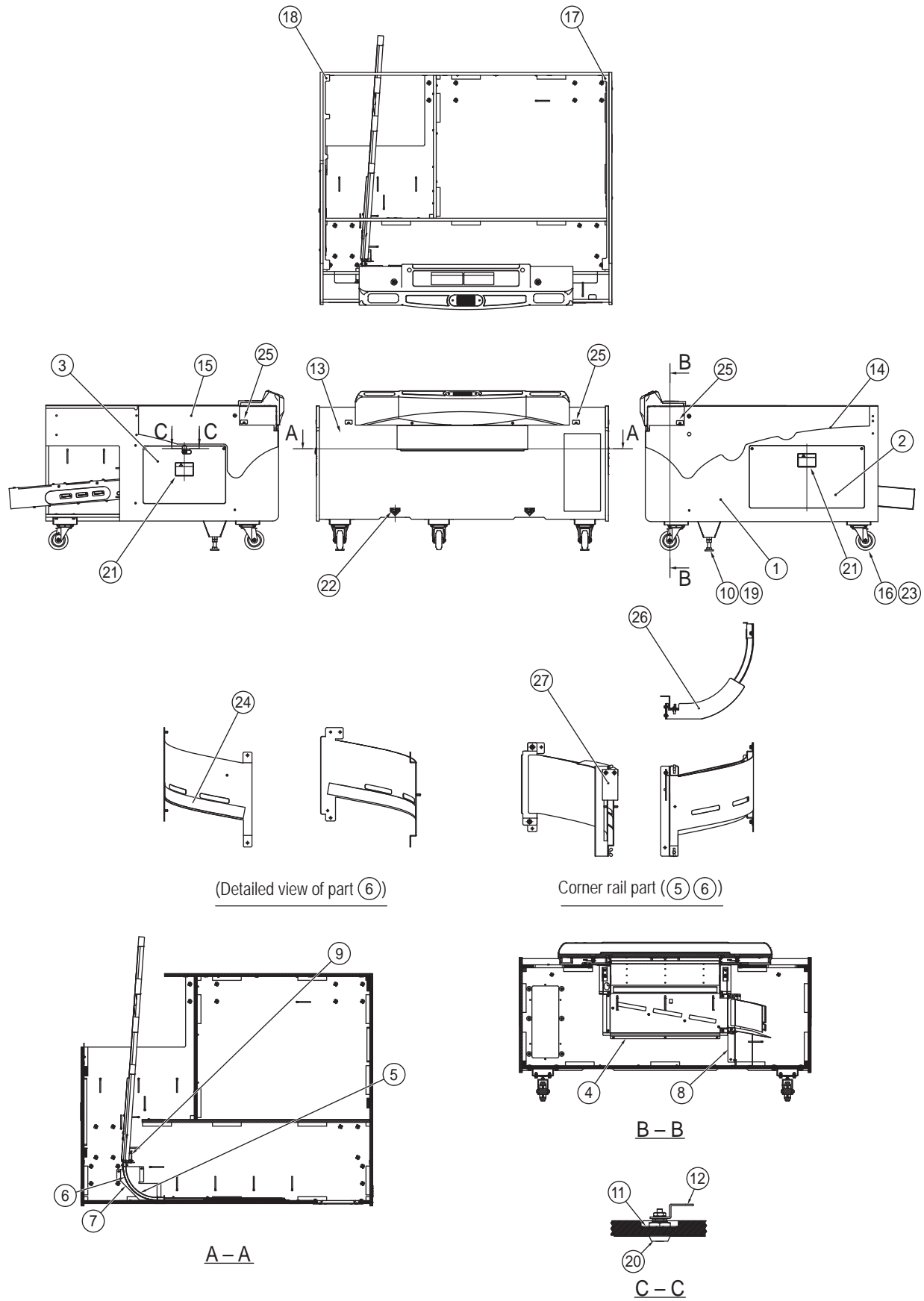

No.	Name	Qty.	Type and rating	Part No.
1	Table cabinet (L) EXP	1		PM63-15730-00
2	Front door	1		PM63-15730-01
3	Service door L	1		PM63-15730-02
4	Goal set bracket	1		PM10-15647-00
5	Corner inner R (L)	1		PM10-15649-00
6	Corner outer R (L)	1		PM10-15650-00
7	Corner bracket 1 (L)	1		PM10-15651-00
8	Corner bracket 2 (L)	1		PM10-15652-00
9	Corner bracket 3 (L)	1		PM10-15653-00
10	Adjuster bracket	2		PM10-15654-00
11	Key washer	1		PM10-15655-00
12	Key plate	1		PM10-15657-00
13	Redemption dummy cover	1		PM10-15658-00
14	Cabinet sticker _L (red) _A_PAC	1		PM40-15704-00
15	Cabinet sticker _S (red) _A_PAC	1		PM40-15706-00
16	Caster bracket (B)	4		PM10-15662-00
17	Air chamber bracket F (L)	1		PM10-15660-00
18	Air chamber bracket R (L)	1		PM10-15661-00
19	Leveling bolt	2	KYW16-75-6B	FU11-05996-00
20	COIN LOCK	1	F750-DS8	VG26-15696-00
21	Warning sticker Service (B) EXP	2		461-677
22	Fork sticker PH	2		VG40-06882-00
23	Caster (swivel type)	4	ML-40039SNB	PM24-15695-00
24	Sliding surface sheet (B)	1		PM10-15502-00
25	Corner cover spacer	4		PM10-15664-00
26	Corner rail cover (L)	1		PM10-15663-00
27	Corner rail stopper	1		PM10-15503-00

1

2

3

4

5

6

7

8A

8B

9

10

11

12

Cabinet (L) assembly

Test Mode

Troubleshooting

10-4 Goal (L) assembly

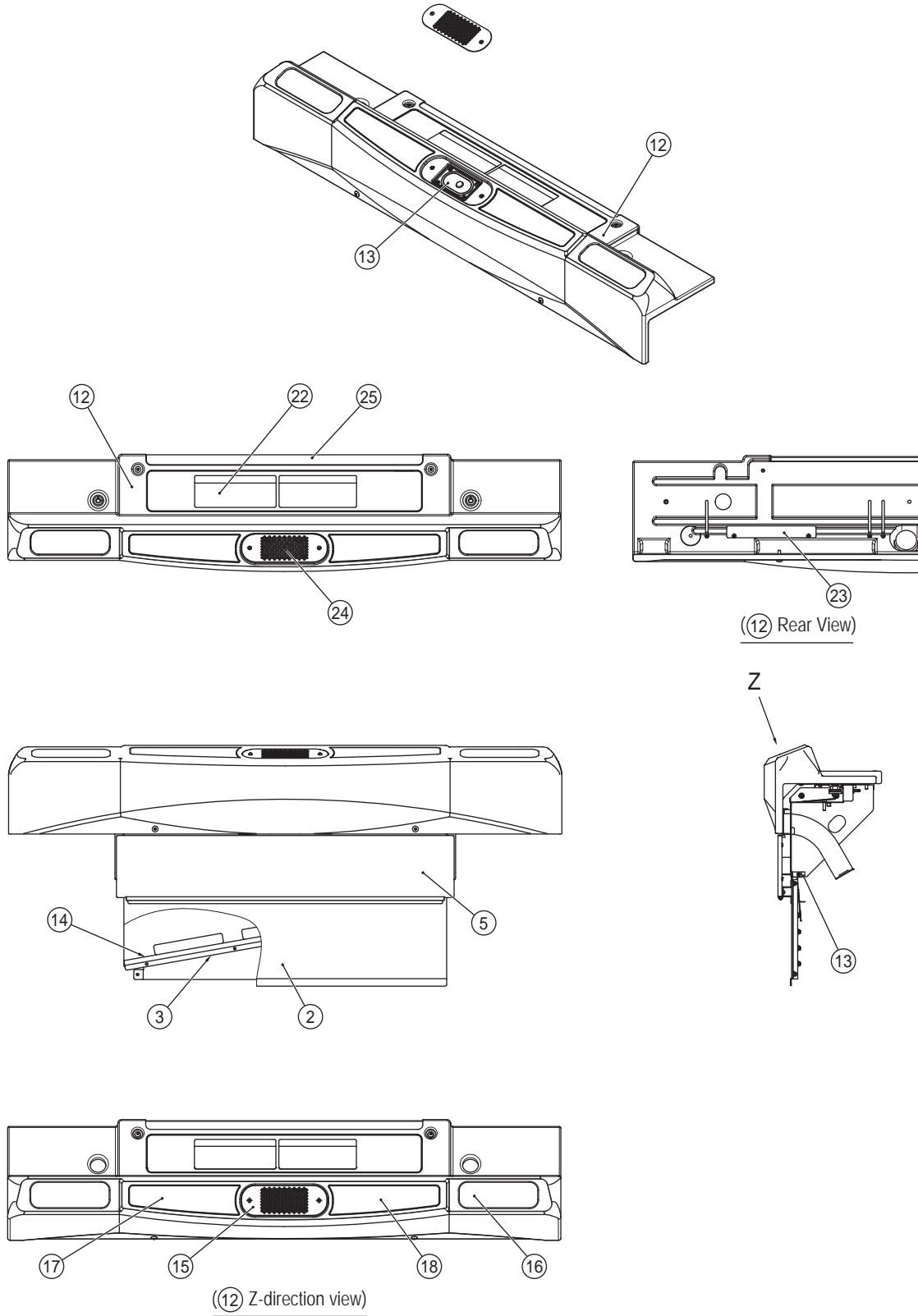

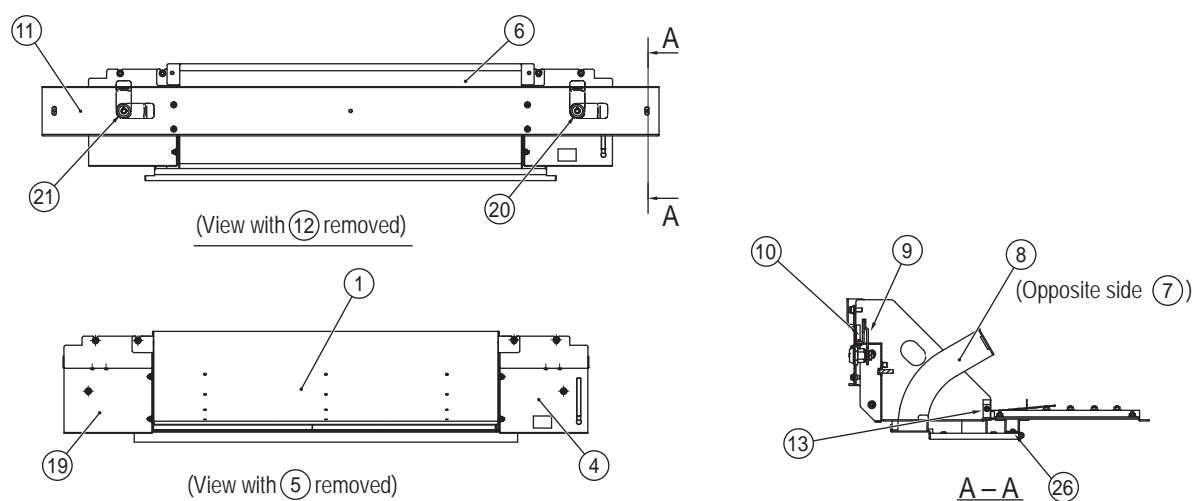

No.	Name	Qty.	Type and rating	Part No.
1	Goal inner R (L)	1		PM10-15528-00
2	Goal outer lower (L)	1		PM10-15529-00
3	Slope	1		PM10-15486-00
4	Lock bracket R	1		PM10-15530-00
5	Goal back plate	1		PM10-15531-00
6	Goal outer R	1		PM10-15532-00
7	Stopper (L)	1		PM10-15487-00
8	Stopper (R)	1		PM10-15487-01
9	Clasp	2		PM10-15533-00
10	Lock hole plate	2		PM10-15534-00
11	Goal outer beam	1		PM10-15535-00
12	Goal cover (B)	1		PM90-15741-00
13	Divided-type photo-interrupter	1	OMT-15D	VG79-09914-00
14	Cushioning rubber	2		PM96-15755-00
15	Speaker panel (R)	1		PM10-15536-00
16	Dummy plate sticker EXP 2	1		PM10-15673-00
17	Instruction sticker (A) (red) EXP	1		PM40-15715-00
18	Instruction sticker (B) (red) EXP	1		PM40-15713-00
19	Lock bracket L	1		PM10-15537-00
20	COIN LOCK	1	F750-DS8	PM26-15696-00
21	COIN LOCK	1	F750-DS8 (two openings)	PM26-15697-00
22	Warning sticker Goal (red) EXP	1		461-769
23	Harness fixing bracket	1		731-381
24	Speaker	1	F2E35A07-4	PM54-15724-00
25	Goal guard sticker (red)	1		PM40-15699-00
26	Goal hinge spacer	1		PM10-15538-00

Goal (L) assembly

Test Mode

Troubleshooting

10-5 Rail (L) assembly

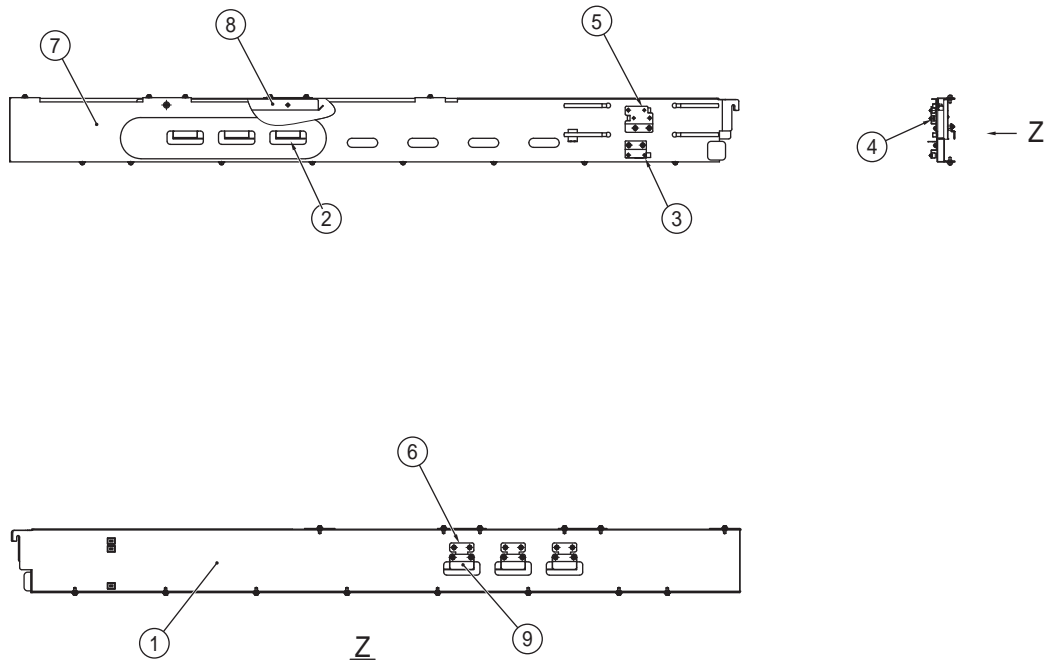

No.	Name	Qty.	Type and rating	Part No.
1	Rail L (A)	1		PM10-15542-00
2	Pendulum	3		PM10-15543-00
3	Rail sensor bracket A	1		PM10-15544-00
4	Reflective-type photo-interrupter	3	GP2A25J00004	PM79-15470-00
5	Rail sensor bracket B	1		PM10-15545-00
6	Pendulum stopper	3		PM10-15546-00
7	Rail L (B)	1		PM10-15547-00
8	L puck stopper	1		PM10-15548-00
9	Pendulum stopper B	3		PM10-15549-00



10-6 Cabinet (R) assembly

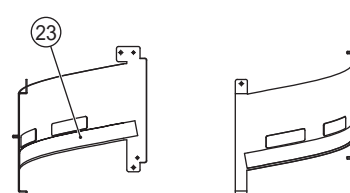
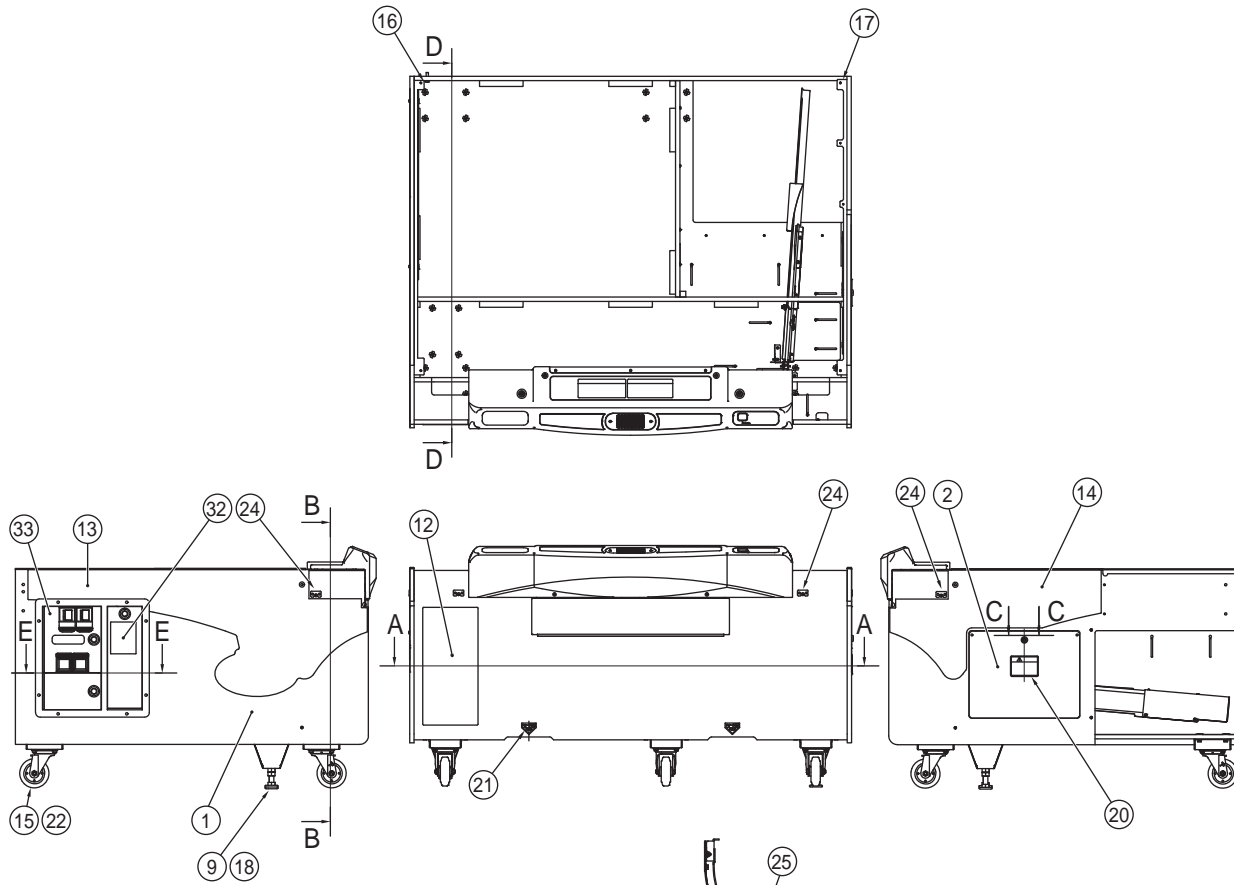

(Detailed view of part 5)

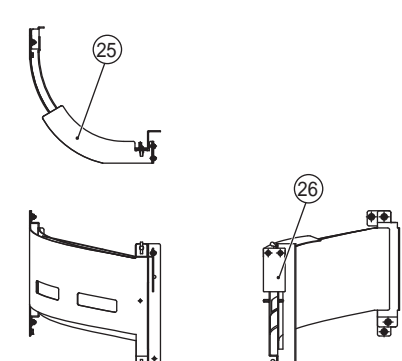

Corner rail part (4 5)

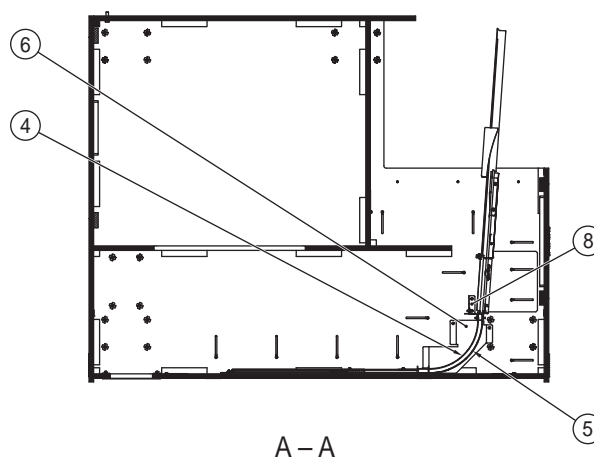

A-A

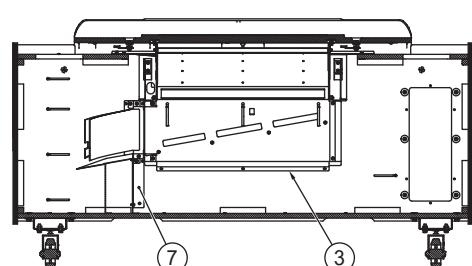

B-B

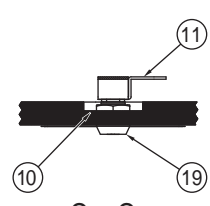

C-C

- 1
- 2
- 3
- 4
- 5
- 6
- 7
- 8A
- 8B
- 9
- 10
- 11
- 12

Rail (L) assembly / Cabinet (R) assembly

Test Mode

Troubleshooting

10. Parts List

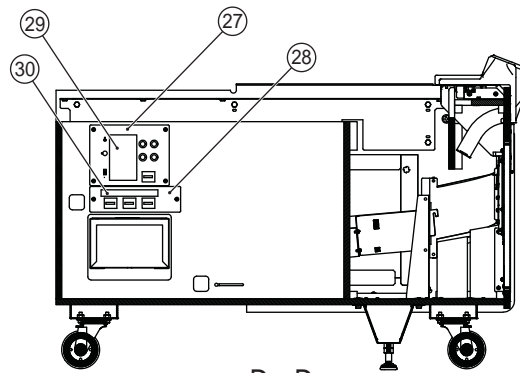

D-D

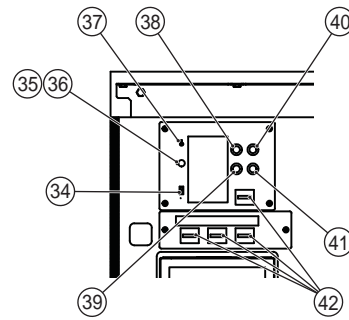

Detailed view of Service panel EX

No.	Name	Qty.	Type and rating	Part No.
1	Table cabinet (R) EXP	1		PM63-15730-03
2	Service door R	1		PM63-15730-04
3	Goal set bracket	1		PM10-15647-00
4	Corner inner (R)	1		PM10-15665-00
5	Corner outner (R)	1		PM10-15666-00
6	Corner bracket 1 (R)	1		PM10-15667-00
7	Corner bracket 2 (R)	1		PM10-15668-00
8	Corner bracket 3 (R)	1		PM10-15669-00
9	Adjuster bracket	2		PM10-15654-00
10	Key washer	1		PM10-15656-00
11	Key plate	1		PM10-15657-00
12	Redemption dummy cover	1		PM10-15658-00
13	Cabinet sticker _L (blue) _A_PAC	1		PM40-15705-00
14	Cabinet sticker _S (blue) _A_PAC	1		PM40-15707-00
15	Caster bracket (B)	4		PM10-15659-00
16	Air chamber bracket F (R)	1		PM10-15670-00
17	Air chamber bracket R (R)	1		PM10-15671-00
18	Leveling bolt	2	KYW16-75-6B	FU11-05996-00
19	COIN LOCK	1	F750-DS8	PM26-15696-00
20	Warning sticker Service (B) (EXP)	2		461-539
21	Fork sticker PH	2		VG40-06882-00
22	Caster (swivel type)	4	ML-40039SNB	PM24-15695-00
23	Sliding surface sheet (B)	1		PM10-15502-00
24	Corner cover spacer	4		PM10-15664-00
25	Corner rail cover (R)	1		PM10-15672-00
26	Corner rail stopper	1		PM10-15503-00
27	Service panel EX	1		PM10-15682-00
28	Counter panel EX	1		PM10-15683-00
29	Service ST (EXP)	1		731-734
30	Counter ST (EXP)	1		731-735
31	Coin cover	1		PM10-15684-00
32	Bill validator cover	1		PM10-15685-00
33	DR ASSY 3IN1 W / DOWNSTACKER VALIDATOR C/O NO MWCHS	1		731-738
34	Slide switch	1	SDS-103A-03#13BJ	PM53-15721-00
35	Volume	1	RK1631110-F20-C0-B103-L	PM78-15733-00
36	Volume knob	1	K-8075-6.1	PM64-15731-00
37	Toggle switch	1	SDSA-331G-CR	PM53-15720-00
38	Push switch (red)	1	SDP-103C-22RB	PM53-15719-00
39	Push switch (green)	1	SDP-103C-22GB	DE453-15411-00
40	Push switch (yellow)	1	SDP-103C-22YB	PM53-15722-00
41	Push switch (blue)	1	SDP-103C-22UB	PM53-15723-00
42	Electromagnetic counter	4	FX-06PD52(12VDC)	VG83-13196-00



10-7 Goal (R) assembly

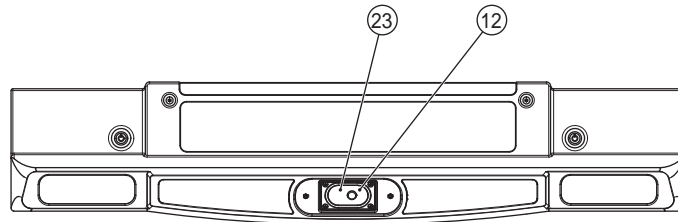

(View with 11 removed)

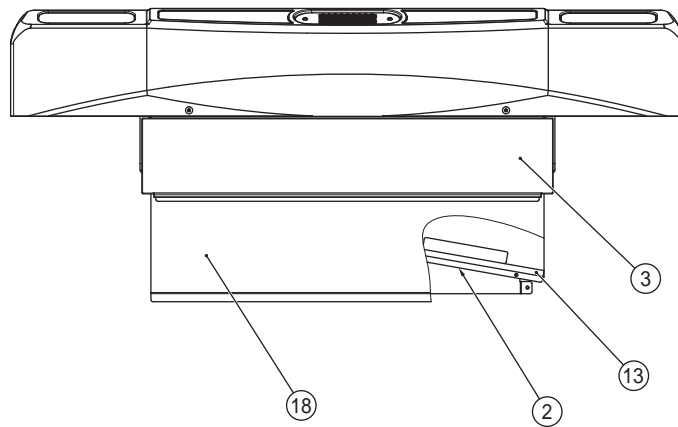
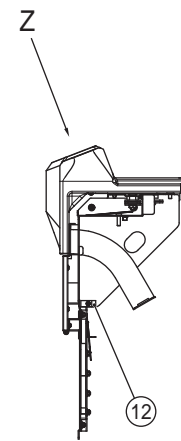
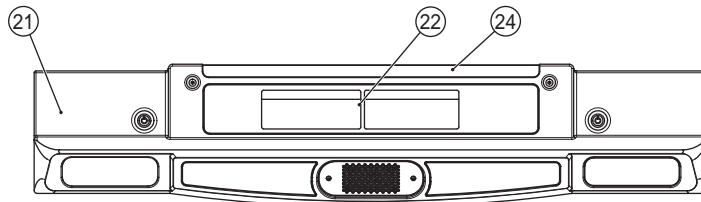

- 1
- 2
- 3
- 4
- 5
- 6
- 7
- 8A
- 8B
- 9
- 10**
- 11
- 12

Cabinet (R) assembly / Goal (R) assembly

Test Mode

Troubleshooting

10. Parts List

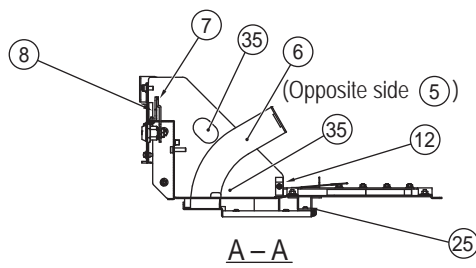
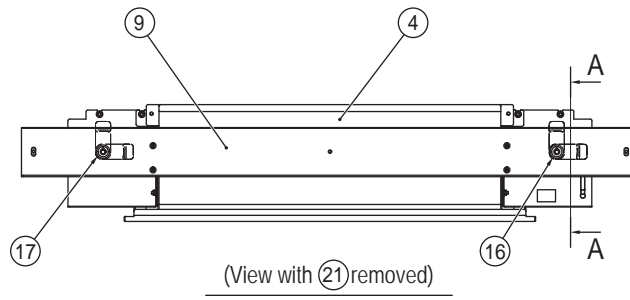
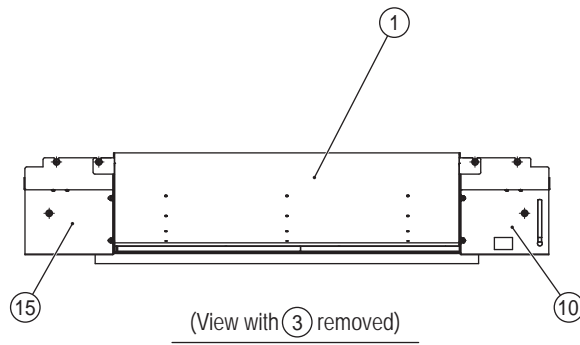
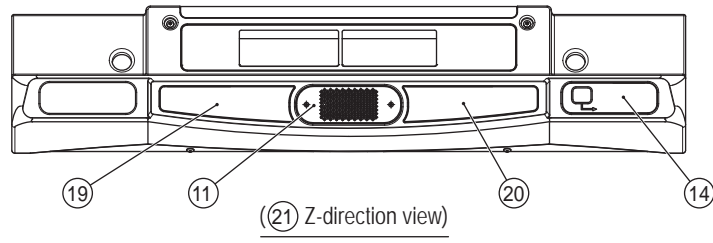

No.	Name	Qty.	Type and rating	Part No.
1	Goal inner R (R)	1		PM10-15539-00
2	Slope	1		PM10-15486-00
3	Goal back plate	1		PM10-15531-00
4	Goal outer R	1		PM10-15532-00
5	Stopper (L)	1		PM10-15487-00
6	Stopper (R)	1		PM10-15487-01
7	Clasp	2		PM10-15533-00
8	Lock hole plate	2		PM10-15534-00
9	Goal outer beam	1		PM10-15535-00
10	Lock bracket R	1		PM10-15530-00
11	Speaker panel (B)	1		PM10-15540-00
12	Divided-type photo-interrupter	1	OMT-15D	VG79-09914-00
13	Cushioning rubber	2		PM96-15755-00
14	Dummy plate sticker EXP 2	1		PM10-15673-00
15	Lock bracket L	1		PM10-15537-00
16	COIN LOCK	1	F750-DS8	PM26-15696-00
17	COIN LOCK	1	F750-DS8 (two openings)	PM26-15697-00
18	Goal outer lower (R)	1		PM10-15541-00
19	Instruction sticker (A) (blue) EXP	1		PM40-15714-00
20	Instruction sticker (B) (blue) EXP	1		PM40-15712-00
21	Goal cover (B)	1		PM90-15742-00
22	Warning sticker Goal (blue) EXP	1		
23	Speaker	1	F2E35A07-4	006-195
24	Goal guard sticker (blue)	1		PM54-15724-00
25	Goal hinge spacer	1		PM10-15538-00

1

2

3

4

5

6

7

8A

8B

9

10

11

12

Goal (R) assembly

Test Mode

Troubleshooting

10-8 Rail (R) assembly

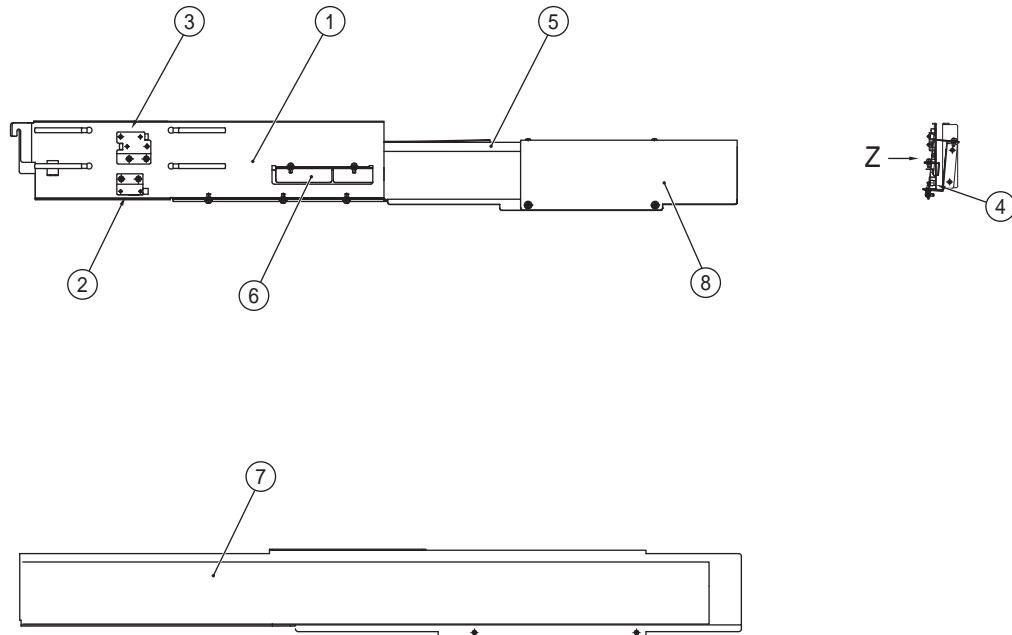

View with ① and ⑧ removed (Z direction)

No.	Name	Qty.	Type and rating	Part No.
1	Rail R (A)	1		PM10-15550-00
2	Rail sensor bracket A	1		PM10-15544-00
3	Rail sensor bracket B	1		PM10-15545-00
4	Reflective-type photo-interrupter	3	GP2A25J00004	PM79-15470-00
5	Rail R (B)	1		PM10-15551-00
6	Alignment plate	1		PM10-15552-00
7	Sliding surface sheet (A)	1		731-418
8	Rail R wall	1		PM10-15553-00



10-9 Side tower assembly

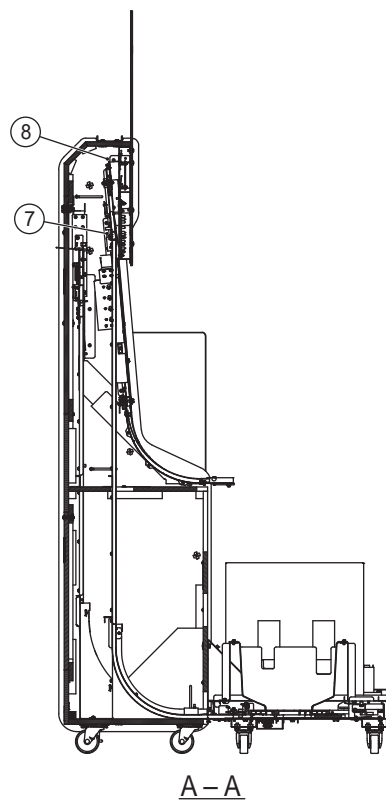
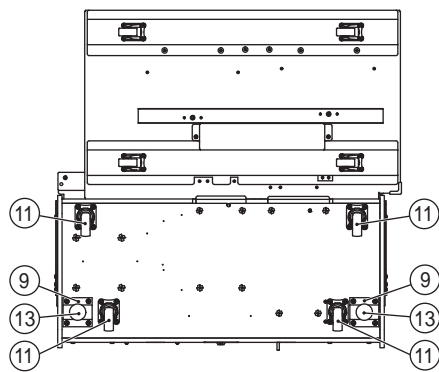
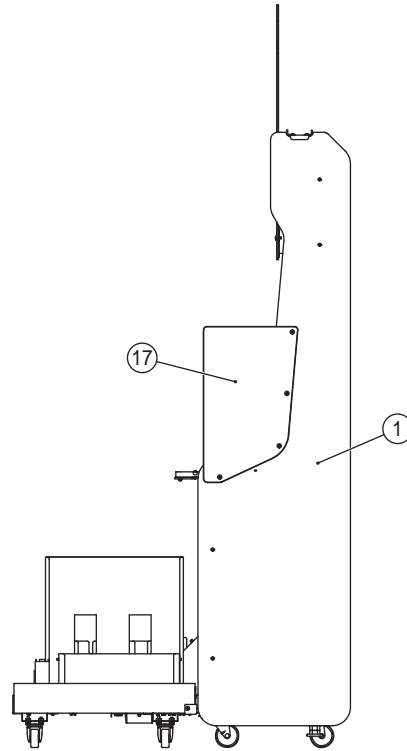
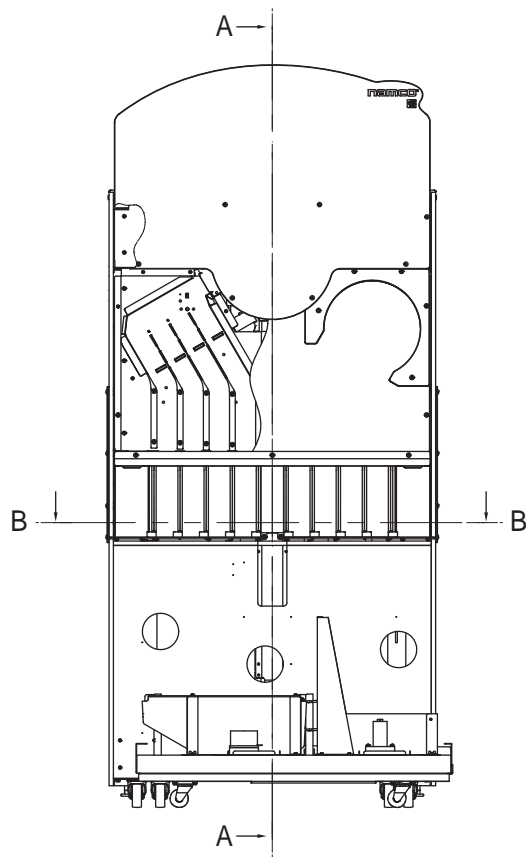

- 1
- 2
- 3
- 4
- 5
- 6
- 7
- 8A
- 8B
- 9
- 10
- 11
- 12

Rail (R) assembly / Side tower assembly

Test Mode

Troubleshooting

10. Parts List

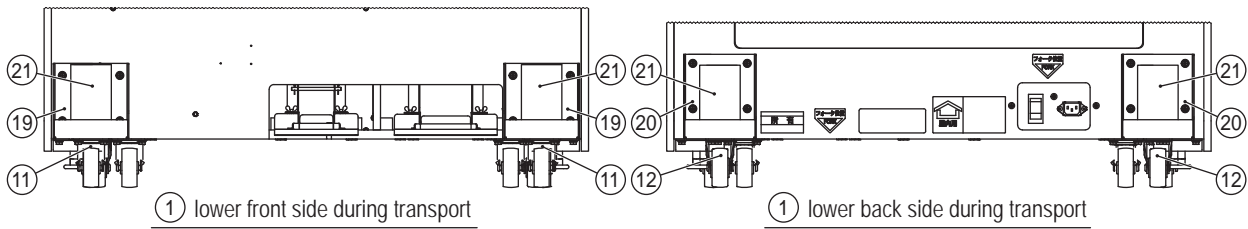
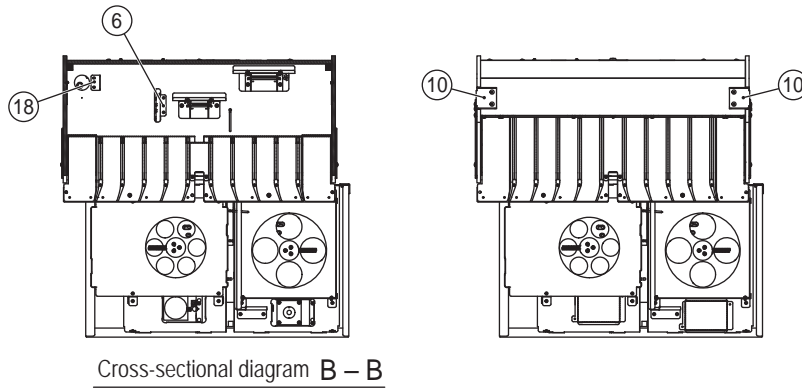
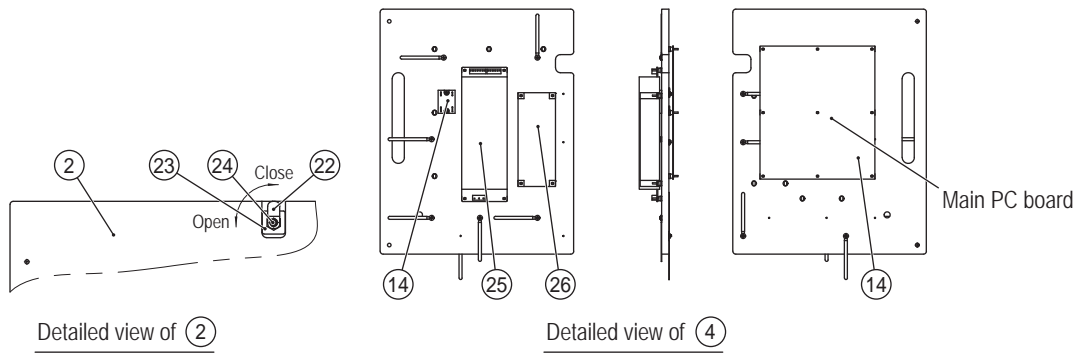
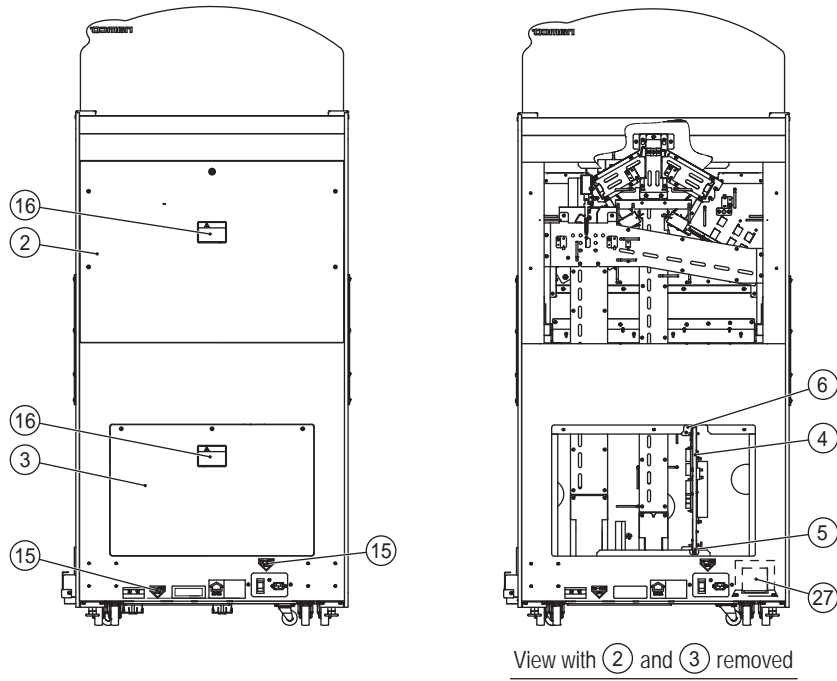

No.	Name	Qty.	Type and rating	Part No.
1	Side tower cabinet (EXP)	1		PM63-15730-05
2	Rear panel	1		PM63-15730-06
3	Service door	1		PM63-15730-07
4	PCB base EXP	1		PM63-15730-08
5	Rack rail L	1		PM10-15554-00
6	Rack rail U	1		PM10-15555-00
7	Slider bracket	2		PM10-15556-00
8	Signboard bracket	2		PM10-15557-00
9	Adjuster bracket	2		PM10-15511-00
10	Rope hook (E)	2		PM10-15512-00
11	Caster (swivel type)	6	ML-20050S	PM24-15692-00
12	Caster (stationary type)	2	ML-20050R	PM24-15693-00
13	Leveling bolt	2	KYW16-75-6B	FU11-05996-00
14	SSR	1	S5C-215LV	PM88-15736-00
15	Fork sticker PH	2		VG40-06882-00
16	Warning sticker Service (B) EXP	2		461-677
17	Side wall	2		PM95-15753-00
18	EX connector panel	1		731-449
19	Caster bracket (F)	2		PM10-15558-00
20	Caster bracket (R)	2		PM10-15559-00
21	Warning sticker Installation and Transport	4		461-770
22	Key plate B	1		PM10-15560-00
23	Key washer	1		PM10-15561-00
24	COIN LOCK	1	F750-DS8	PM26-15696-00
25	Switching regulator (24 V)	1	VS150P-24	PM88-15737-00
26	Switching regulator (12 V)	1	VS100E-12	PM88-15738-00
27	Transformer	1	S133V100PV	PM56-15726-00

1

2

3

4

5

6

7

8A

8B

9

10

11

12

Side tower assembly

Test Mode

Troubleshooting

10-10 Hopper assembly

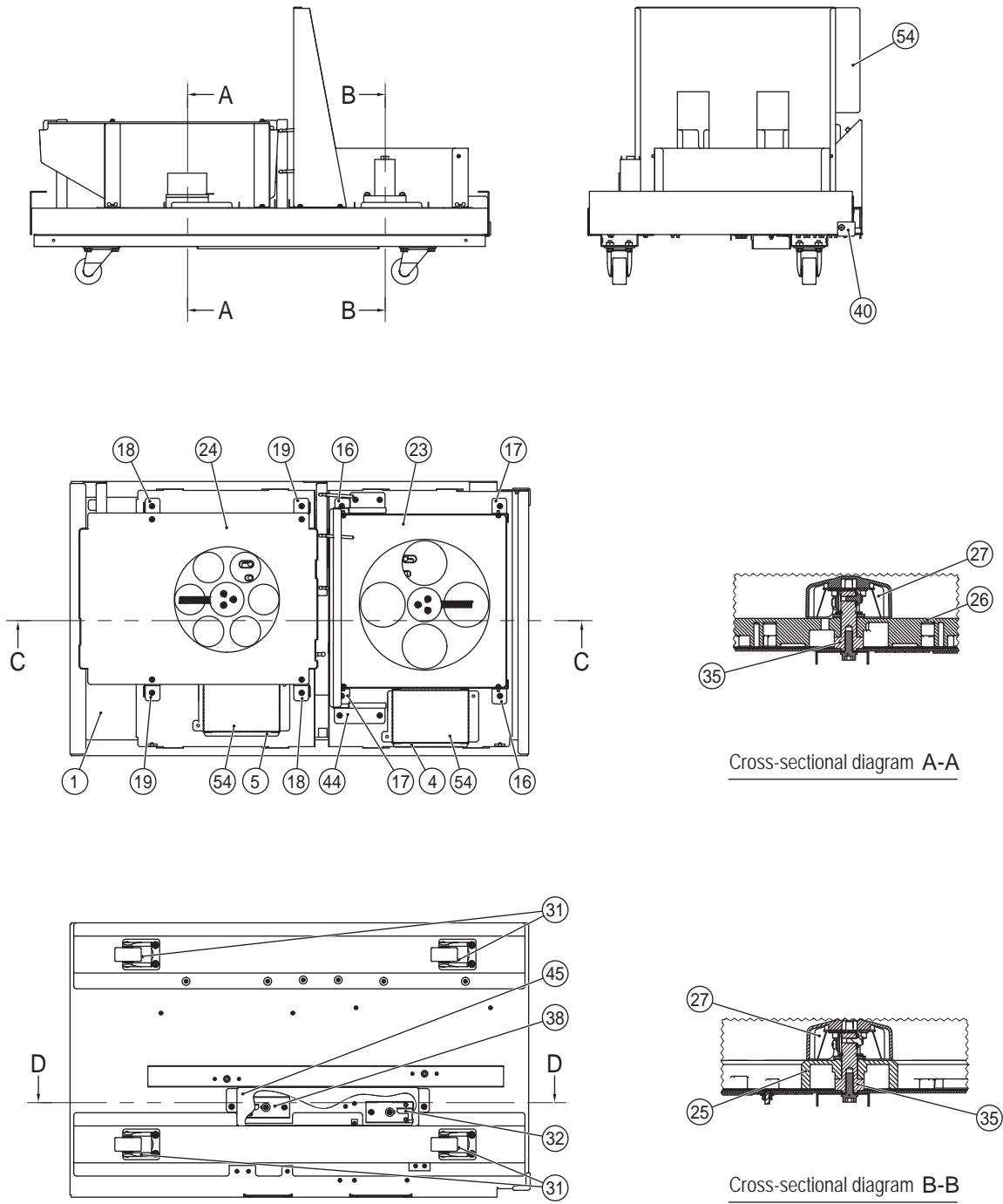



10. Parts List

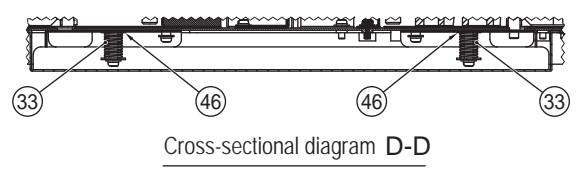
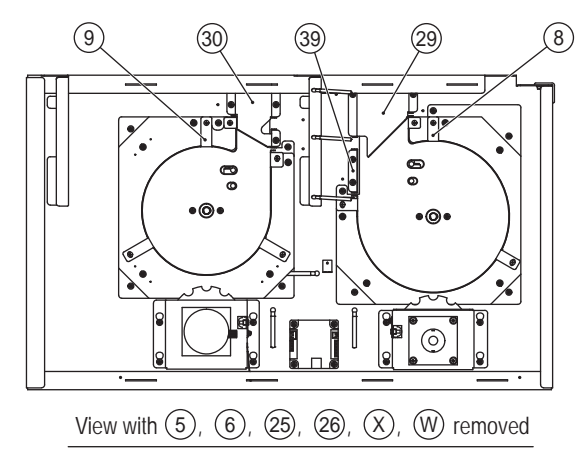
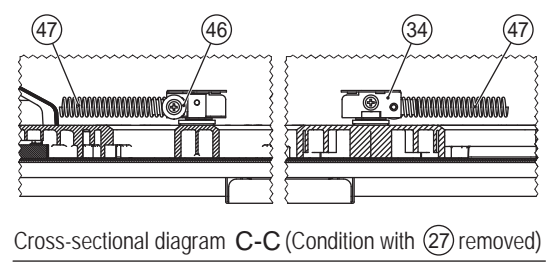
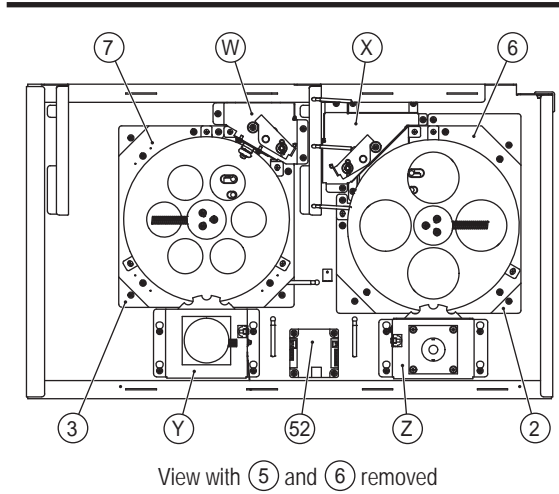

- 1
- 2
- 3
- 4
- 5
- 6
- 7
- 8A
- 8B
- 9
- 10**
- 11
- 12

Hopper assembly

Test Mode

Troubleshooting

10. Parts List

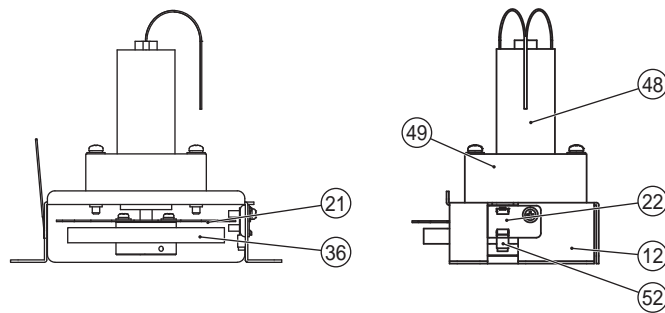

Detailed view of part (Z)

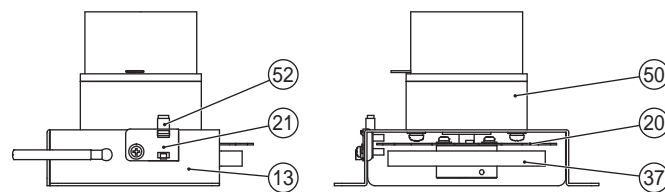

Detailed view of part (Y)

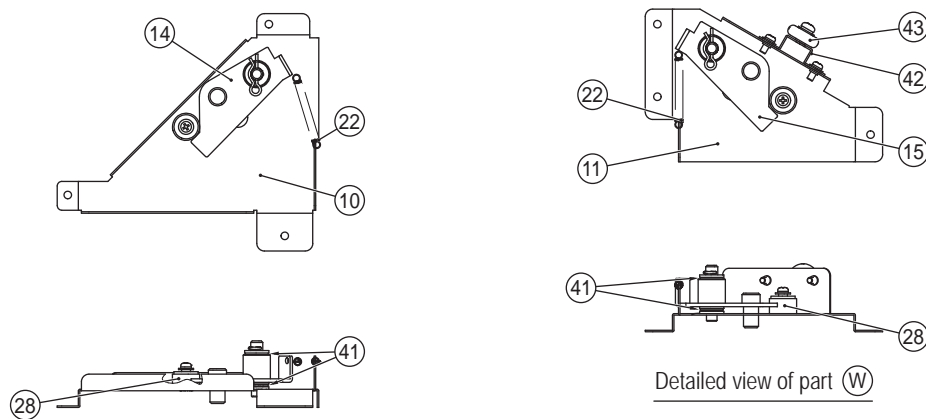

Detailed view of part (X)

Detailed view of part (W)

No.	Name	Qty.	Type and rating	Part No.
1	Hopper base	1		PM10-15562-00
2	L hopper bottom	1		PM10-15563-00
3	S hopper bottom	1		PM10-15564-00
4	L hopper cover (EXP)	1		PM10-15686-00
5	S hopper cover (EXP)	1		PM10-15687-00
6	L hopper under	1		PM63-15730-09
7	S hopper under	1		PM63-15730-10
8	L hopper puck guide	1		PM10-15565-00
9	S hopper puck guide	1		PM10-15566-00
10	L hopper latch base	1		PM10-15567-00
11	S hopper latch base	1		PM10-15568-00

No.	Name	Qty.	Type and rating	Part No.
12	L hopper motor bracket EXP	1		PM10-15688-00
13	S hopper motor bracket	1		PM10-15569-00
14	L hopper latch	1		PM10-15570-00
15	S hopper latch	1		PM10-15571-00
16	L bucket base A	2		PM10-15572-00
17	L bucket base B	2		PM10-15573-00
18	S bucket base A	2		PM10-15574-00
19	S bucket base B	2		PM10-15575-00
20	Encoder disk	2		PM10-15576-00
21	Encoder bracket	2		PM10-15577-00
22	Latch spring	2		PM10-15488-00
23	L bucket	1		PM90-15743-00
24	S bucket	1		PM90-15744-00
25	L hopper disk	1		PM90-15745-00
26	S hopper disk	1		PM90-15746-00
27	Disk top	2		PM90-15747-00
28	Latch stopper rubber	2		PM96-15756-00
29	L hopper exit	1		PM10-15579-00
30	S hopper exit	1		PM10-15580-00
31	Caster (swivel type)	4	ML-112-ANB	PM24-15694-00
32	Guide pin L	1		PM10-15581-00
33	Guide pin spring	2		PM22-15489-00
34	Hopper spring base	2		PM10-15490-00
35	Disk shaft	2		PM11-15491-00
36	L hopper gear	1		PM90-15748-00
37	S hopper gear	1		PM90-15749-00
38	Guide pin S	1		PM10-15582-00
39	L hopper exit B	1		PM10-15583-00
40	Point cover (S)	1		PM90-15739-00
41	Flange bushing	4	80F-0805	PM59-15729-00
42	Disk retainer bracket	1		PM10-15584-00
43	Roller	1		PM90-15750-00
44	Hopper wall	1		PM10-15585-00
45	Guide pin cover	1		PM10-15586-00
46	S washer	2		PM21-15492-00
47	Hopper spring	2		PM22-15493-00
48	DC motor (L hopper motor)	1	DMN37H8HP-017	PM58-15727-00
49	Gear head (for DC brush motor)	1	8DG60-10	PM58-15759-00
50	DC brushless motor (S hopper motor) (with gear head)	1		PM58-15478-00
51	Motor driver PC board	1	TD12900A-244M03	PM15-15477-00
52	Transmissive-type photo-interrupter	2	GP5A71AJ000F	PM79-15471-00
53	Hopper wall B	1		PM10-15587-00
54	Motor cover	2		PM58-15728-00

1

2

3

4

5

6

7

8A

8B

9

10

11

12

Hopper assembly

Test Mode

Troubleshooting

10-11 Slider assembly

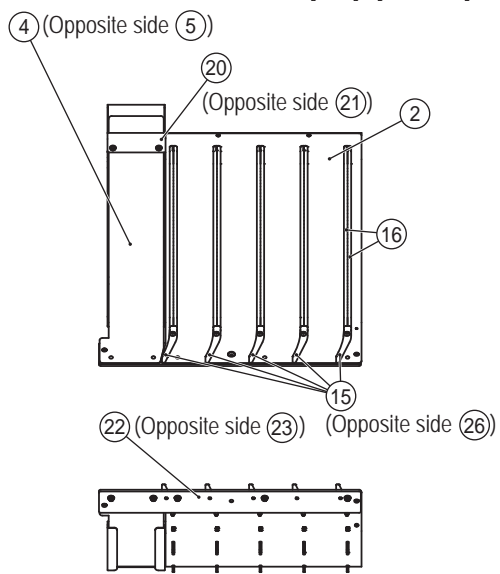
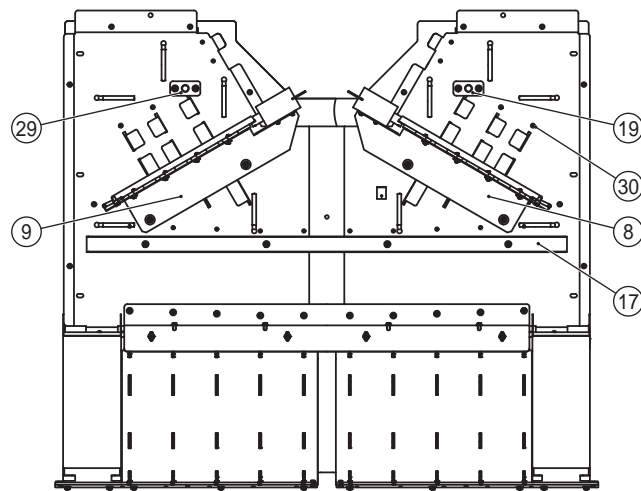
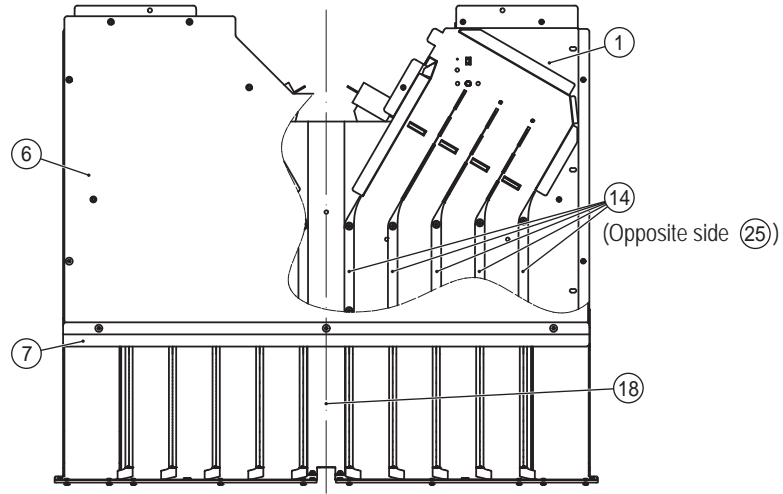

Detailed view of ② and ③ (The figure shows ②.)

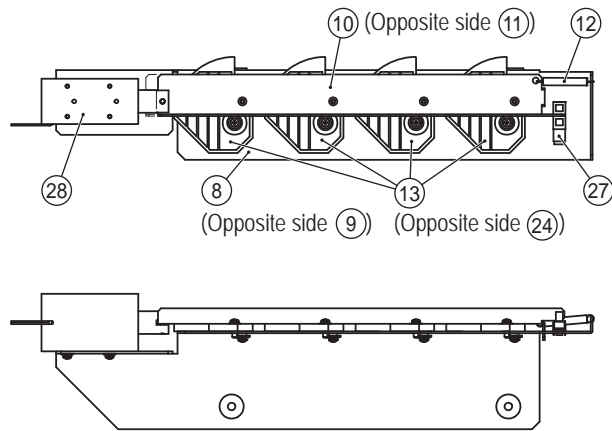

Detailed view of ⑧ and ⑨ (The figure shows ⑧.)

No.	Name	Qty.	Type and rating	Part No.
1	Slider base	1		PM10-15588-00
2	S slope L	1		PM10-15589-00
3	S slope R	1		PM10-15590-00
4	L slope L	1		PM10-15591-00
5	L slope R	1		PM10-15592-00
6	Cover panel (PAC)	1		PM40-15708-00
7	Cover panel retainer L	1		PM10-15593-00
8	Stopper base L	1		PM10-15594-00
9	Stopper base R	1		PM10-15595-00
10	Stopper link L	1		PM10-15596-00
11	Stopper link R	1		PM10-15597-00
12	Stopper spring	2		PM22-15690-00
13	Stopper L	4		PM90-15494-00
14	Slider rail L	5		PM90-15495-00
15	Guide L	5		PM90-15496-00
16	Slope rail	20		PM90-15497-00
17	Beam	1		PM10-15498-00
18	Blind	1		PM10-15499-00
19	Entrance pin L	2		PM10-15600-00
20	Slope joint U (L)	1		PM10-15601-00
21	Slope joint U (R)	1		PM10-15602-00
22	Slope bumper L	1		PM10-15703-00
23	Slope bumper R	1		PM10-15704-00
24	Stopper R	4		PM90-15494-01
25	Slider rail R	5		PM90-15495-01
26	Guide R	5		PM90-15496-01
27	Transmissive-type photo-interrupter (Stopper sensor)	2	GP5A71AJ000F	PM79-15471-00
28	Solenoid	2	SDC-1564-BNG	PM36-15476-00
29	Entrance pin R	1		PM10-15605-00
30	Entrance pin T	4		PM10-15606-00

1

2

3

4

5

6

7

8A

8B

9

10

11

12

Slider assembly

Test Mode

Troubleshooting

10-12 S escalator assembly

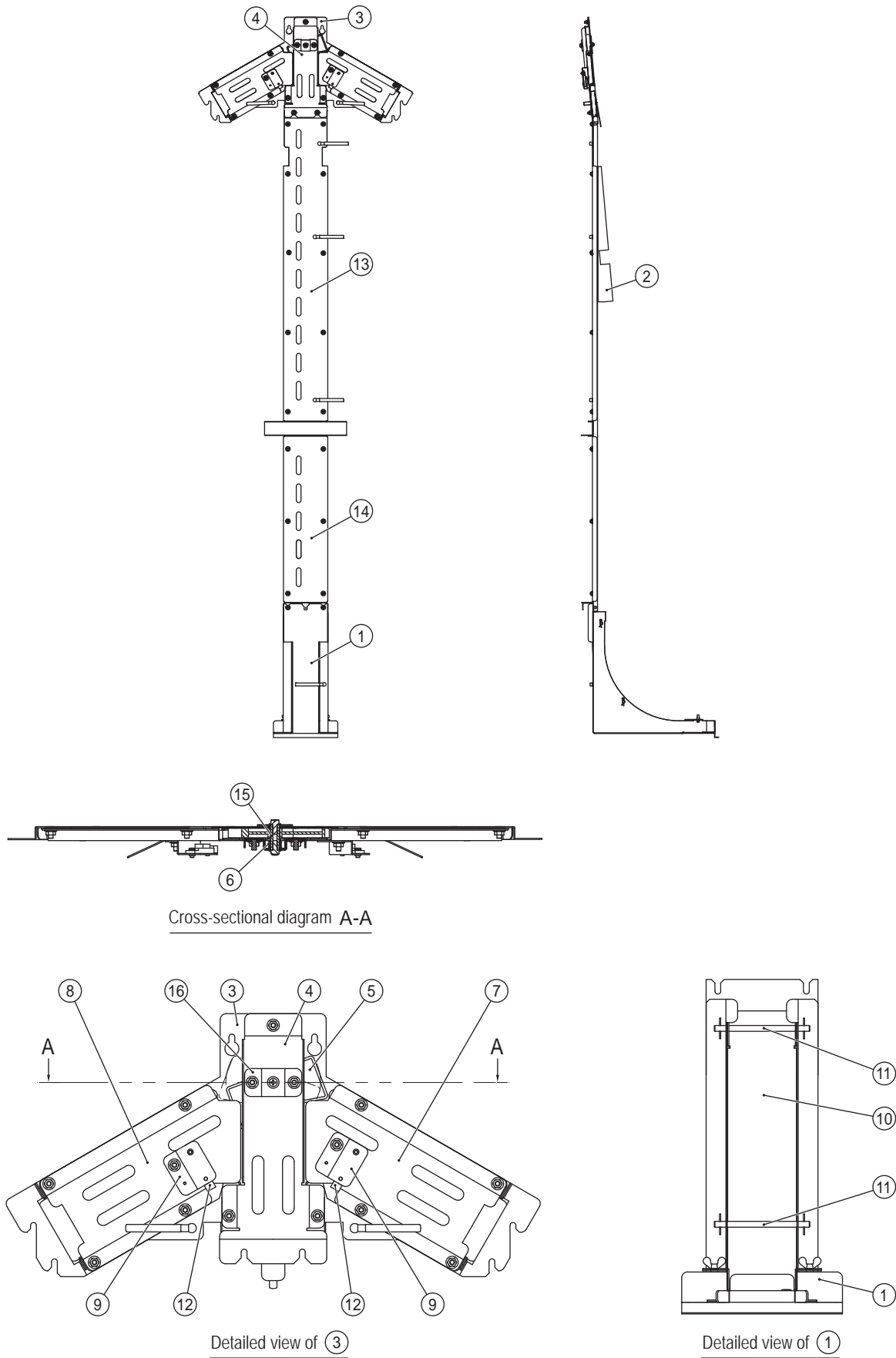

10. Parts List

No.	Name	Qty.	Type and rating	Part No.
1	S rail (R)	1		PM10-15607-00
2	S rail (L)	1		PM10-15608-00
3	S divider base	1		PM10-15609-00
4	S divider cover	1		PM10-15610-00
5	S divider	1		PM90-15498-00
6	S divider spring	1		PM22-15691-00
7	Joint rail cover L	1		PM10-15611-00
8	Joint rail cover R	1		PM10-15612-00
9	Escalator sensor bracket	2		PM10-15618-00
10	S rail (R) lid	1		PM10-15613-00
11	Lid pin S	2		PM10-15499-00
12	Reflective-type photo-interrupter	2	GP2A25J00004	PM79-15470-00
13	S rail (V) cover (U)	1		PM10-15614-00
14	S rail (V) cover (L)	1		PM10-15615-00
15	S divider shaft	1		PM10-15616-00
16	Shaft retainer	1		PM10-15617-00

- 1
- 2
- 3
- 4
- 5
- 6
- 7
- 8A
- 8B
- 9
- 10
- 11
- 12

Escalator assembly

Test Mode

Troubleshooting

10-13 L escalator assembly

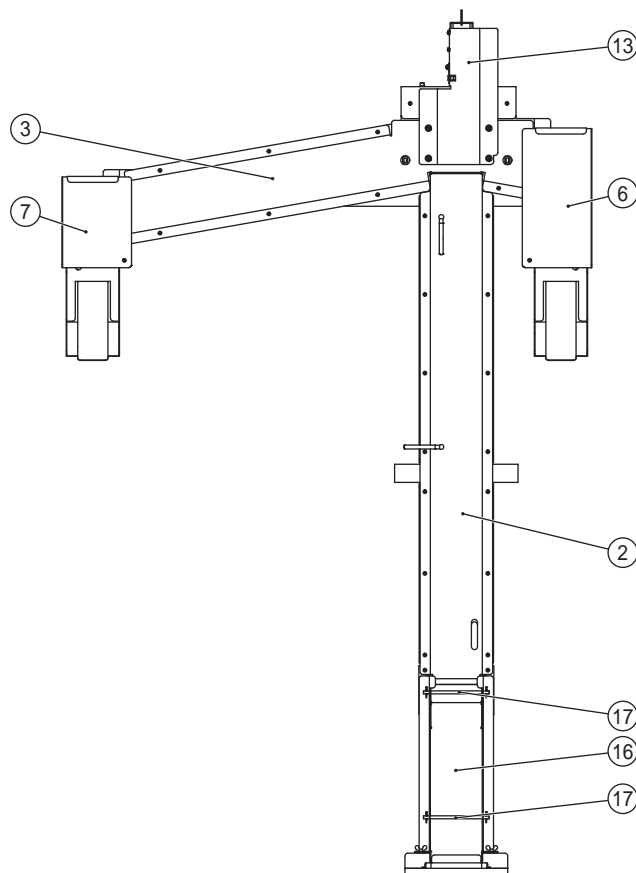
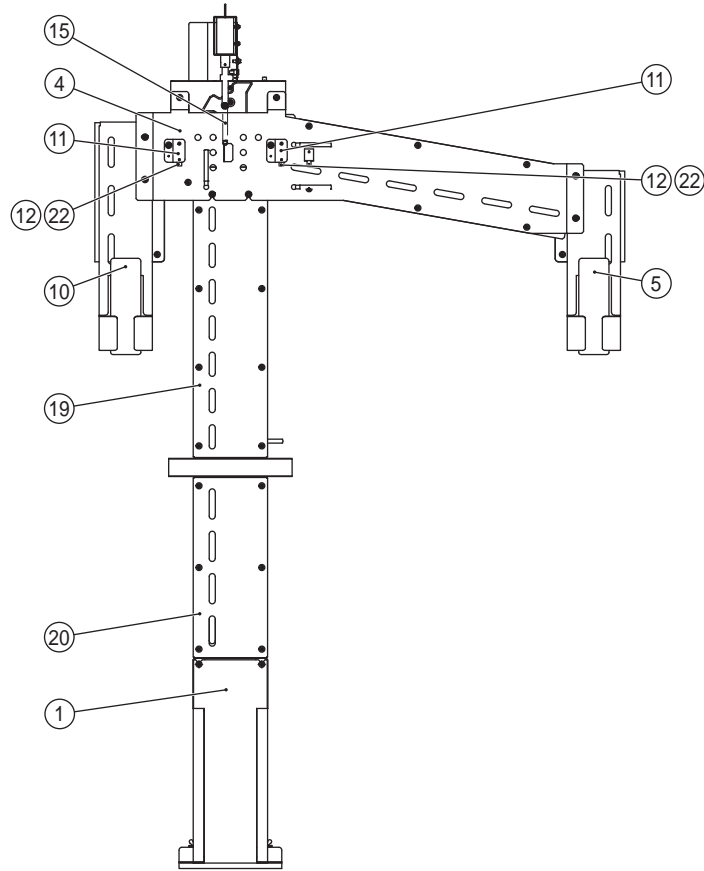

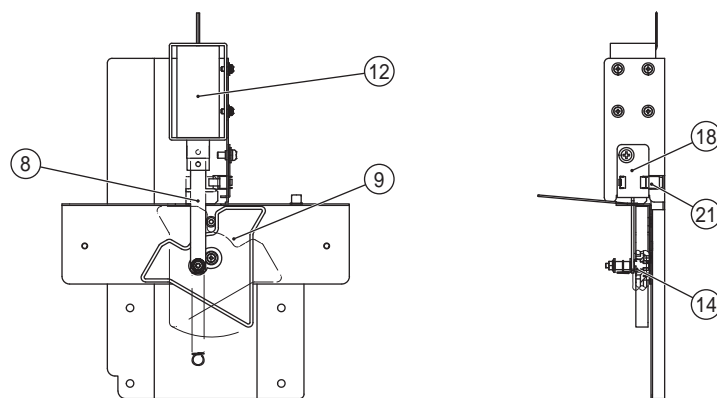

Detailed view of ③

- 1
- 2
- 3
- 4
- 5
- 6
- 7
- 8A
- 8B
- 9
- 10
- 11
- 12

Escalator assembly

No.	Name	Qty.	Type and rating	Part No.
1	L rail (R)	1		PM10-15620-00
2	L rail (V)	1		PM10-15621-00
3	L rail (H)	1		PM10-15622-00
4	L rail (H) cover	1		PM10-15623-00
5	L slope top L	1		PM10-15624-00
6	L slope top bracket _L	1		PM10-15625-00
7	L slope top bracket _R	1		PM10-15626-00
8	Divider link	1		PM10-15627-00
9	L divider	1		PM90-15751-00
10	L slope top R	1		PM10-15628-00
11	Escalator sensor bracket	2		PM10-15618-00
12	Solenoid	1	SDC-1564-BNG	PM36-15476-00
13	Solenoid base	1		PM10-15629-00
14	Divider link shaft	1		PM10-15630-00
15	Sivider spring	1		PM22-15500-00
16	L rail (R) lid	1		PM10-15631-00
17	Lid pin L	2		PM10-15510-00
18	Encoder bracket	1		PM10-15577-00
19	L rail (V) cover (U)	1		PM10-15632-00
20	L rail (V) cover (L)	1		PM10-15633-00
21	Transmissive-type photo-interrupter (L divider sensor)	1	GP5A71AJ000F	PM79-15471-00
22	Reflective-type photo-interrupter (L divider outlet sensor)	2	GP2A25J00004	PM79-15470-00

Test Mode

Troubleshooting

10-14 Signboard assembly

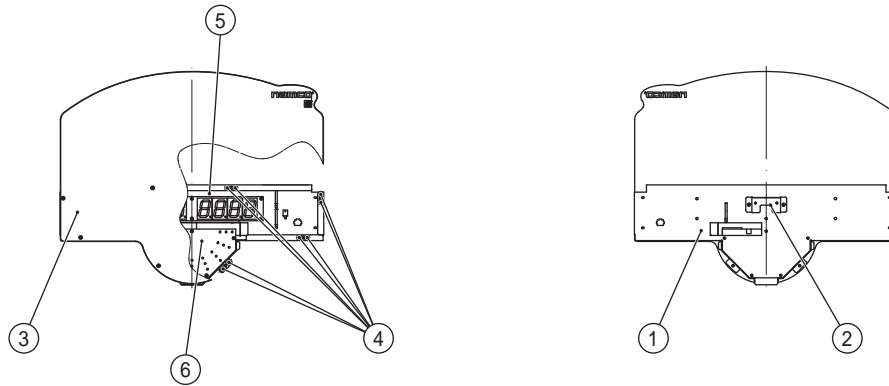

No.	Name	Qty.	Type and rating	Part No.
1	Signboard base	1		PM10-15634-00
2	Divider hook	1		PM10-15635-00
3	Signboard (PAC)	1		PM40-15709-00
4	Signboard cushion	16		731-588
5	Score LED PC board	1		PM15-15475-00
6	Time LED PC board	1		PM15-15474-00

10-15 Switch plate

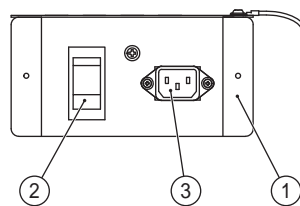

No.	Name	Qty.	Type and rating	Part No.
1	Switch plate	1		PM10-15636-00
2	Power switch	1	BAM210131	PM53-15760-00
3	Noise filter	1	10GEEG3E-R	PM78-15732-00

10-16 Illuminator assembly

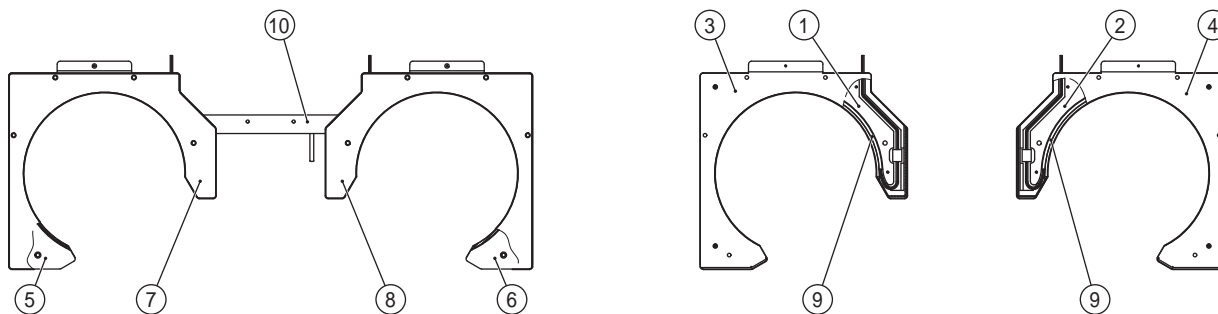

No.	Name	Qty.	Type and rating	Part No.
1	Illumination base (L)	1		PM63-15730-11
2	Illumination base (R)	1		PM63-15730-12
3	Illumination base plate (L)	1		PM10-15637-00
4	Illumination base plate (R)	1		PM10-15638-00
5	Illumination plate (L)	1		PM40-15701-00
6	Illumination plate (R)	1		PM40-15702-00
7	Illumination sticker_PAC (L)	1		PM40-15710-00
8	Illumination sticker_PAC (R)	1		PM40-15711-00
9	Circle LED	2	5050RGB-0C-12V- XA4R-L0600	PM79-15734-00
10	Illuminator harness base	1		731-608

- 1
- 2
- 3
- 4
- 5
- 6
- 7
- 8A
- 8B
- 9
- 10**
- 11
- 12

Signboard assembly / Cord box assembly / Illuminator assembly

Test Mode

Troubleshooting

10-17 Light Assembly

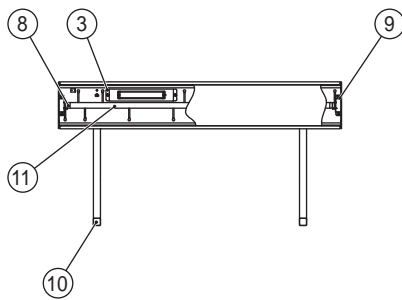
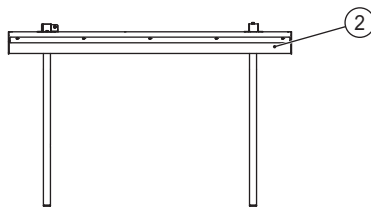
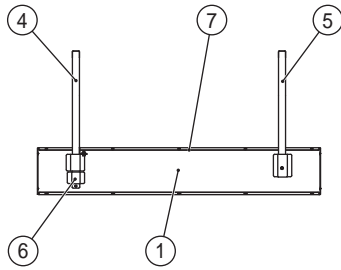

No.	Name	Qty.	Type and rating	Part No.
1	Light frame	1		PM10-15674-00
2	Light cover	1		PM40-15718-00
3	Ballast bracket	1		PM10-15675-00
4	Light arm L	1		PM10-15676-00
5	Light arm R	1		PM10-15677-00
6	Light connector cover	1		PM10-15678-00
7	Light cover retainer	1		PM10-15679-00
8	Socket base L	1		PM10-15680-00
9	Socket base R	1		PM10-15681-00
10	Pipe cap	1		PM90-15752-00
11	LED fluorescent light	1		PM79-15735-00

11. Wiring Diagram

(1/5)

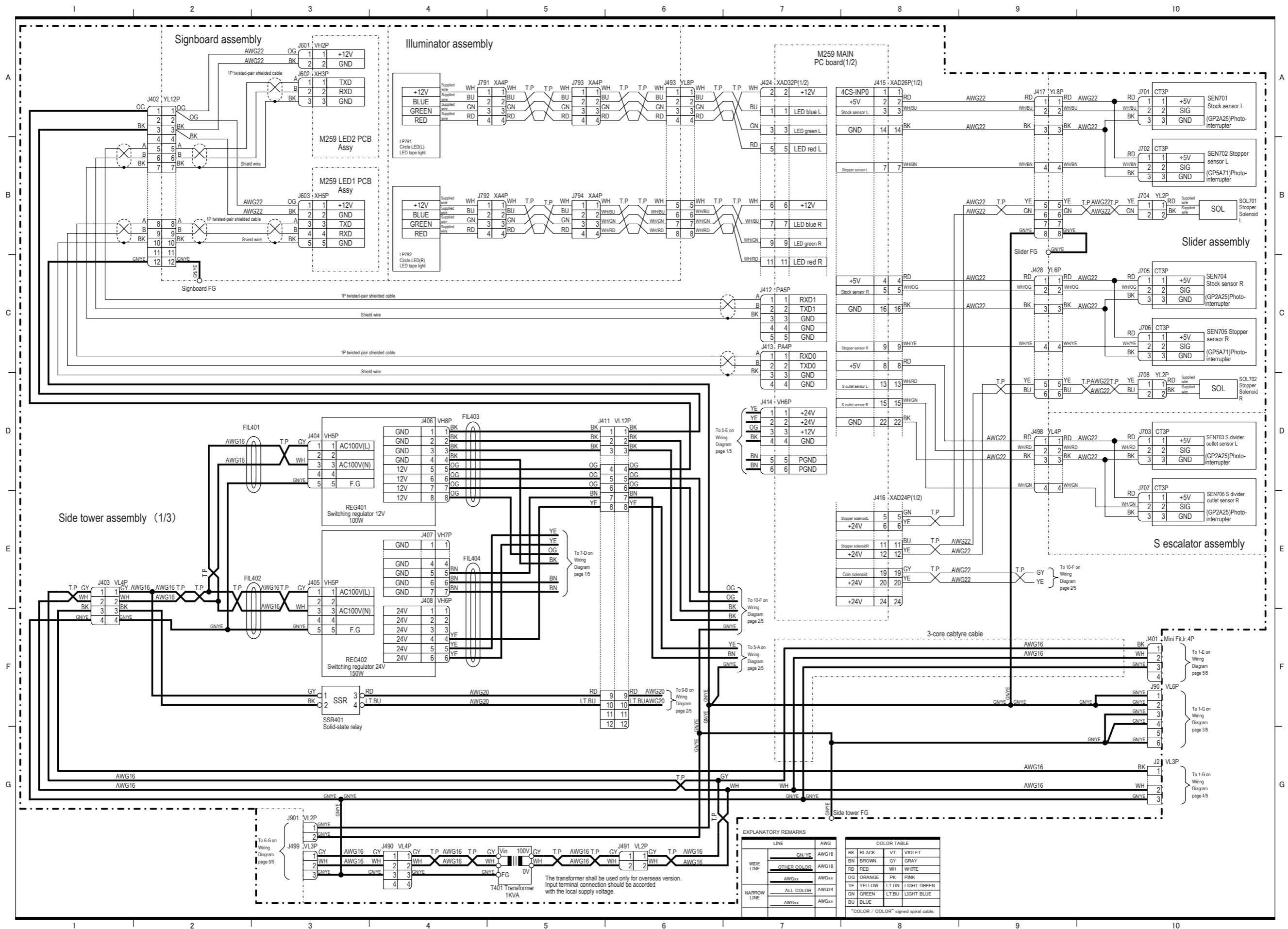

- 1
- 2
- 3
- 4
- 5
- 6
- 7
- 8A
- 8B
- 9
- 10
- 11
- 12

Wiring Diagram

Test Mode

Troubleshooting

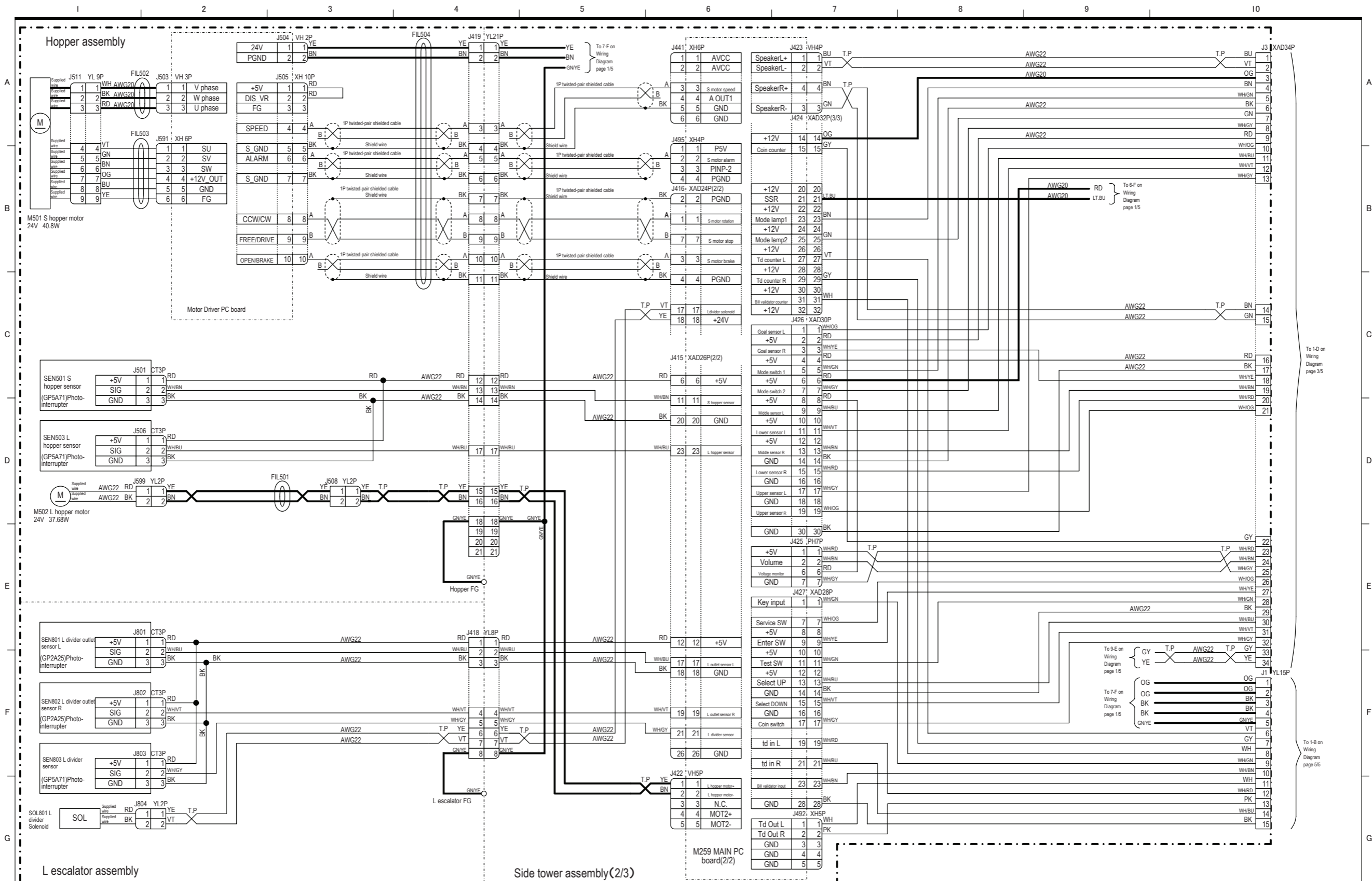

EXPLANATORY REMARKS

LINE	AWG	COLOR TABLE
WIDE LINE	GN/YE	AWG18
	OTHER COLOR	AWG18
	AWG22	AWG22
NARROW LINE	ALL COLOR	AWG24
	AWG22	AWG22

LINE	AWG	COLOR TABLE	
BK	BLACK	VT	VIOLET
BN	BROWN	GY	GRAY
RD	RED	WH	WHITE
OG	ORANGE	PK	PINK
YE	YELLOW	LTGN	LIGHT GREEN
GN	GREEN	LTBU	LIGHT BLUE
BU	BLUE		

*"COLOR / COLOR" signed spiral cable.

- 1
- 2
- 3
- 4
- 5
- 6
- 7
- 8A
- 8B
- 9
- 10
- 11
- 12

Wiring Diagram

Test Mode

Troubleshooting

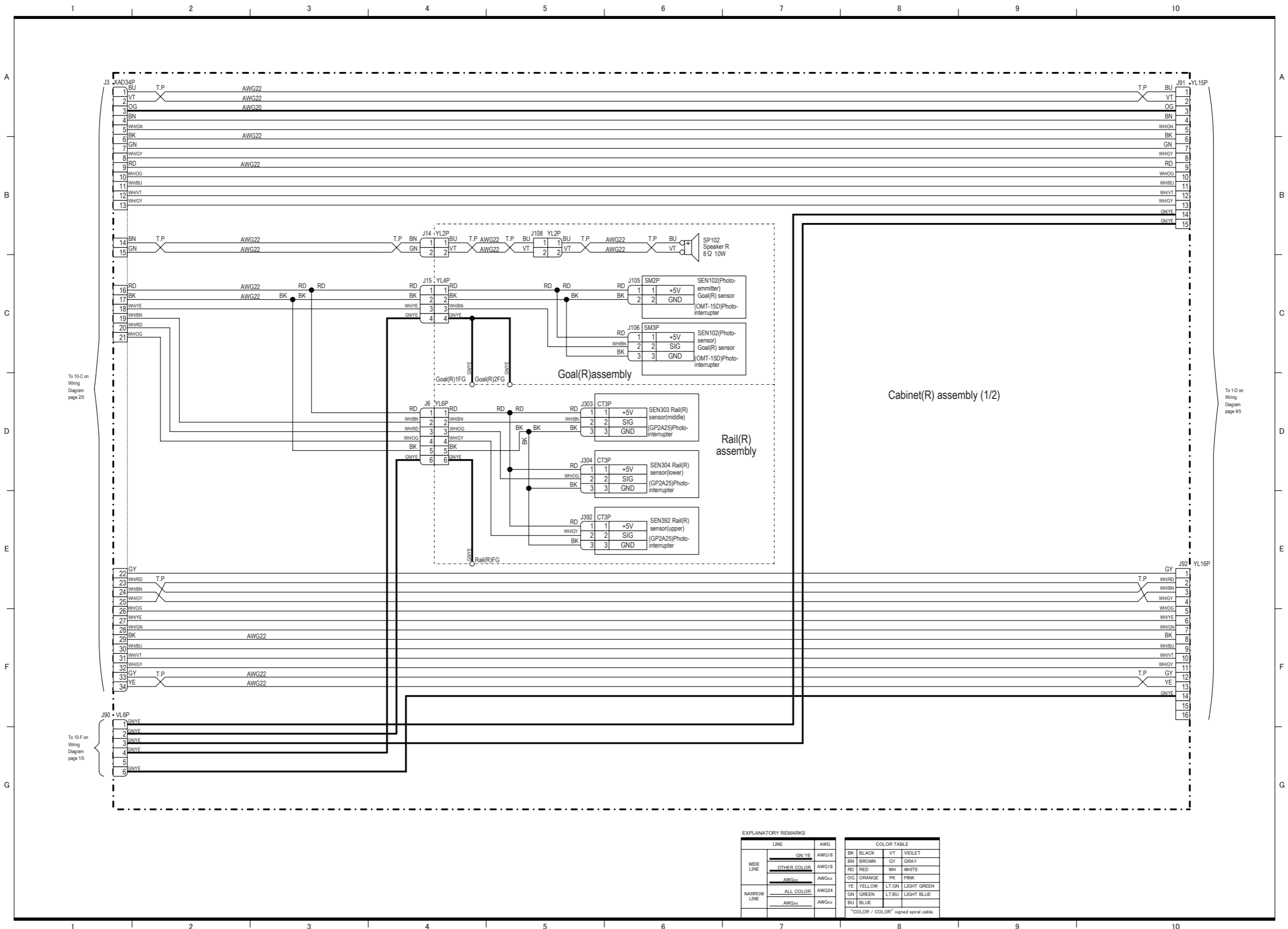

To 10-C on Wiring Diagram page 2/5

To 1-D on Wiring Diagram page 4/5

To 10-F on Wiring Diagram page 1/5

EXPLANATORY REMARKS

LINE	AWG	COLOR TABLE
WIDE LINE	GN/YE	AWG18
OTHER COLOR	AWG18	
NARROW LINE	ALL COLOR	AWG24
AWG24	AWG24	

COLOR	CODE	COLOR	CODE
BK	BLACK	VT	VIOLET
BN	BROWN	GY	GRAY
RD	RED	WH	WHITE
OG	ORANGE	PK	PINK
YE	YELLOW	LT.GN	LIGHT GREEN
GN	GREEN	LT.BU	LIGHT BLUE
BU	BLUE		

*"COLOR / COLOR" signed spiral cable.

- 1
- 2
- 3
- 4
- 5
- 6
- 7
- 8A
- 8B
- 9
- 10
- 11
- 12

Wiring Diagram

Test Mode

Troubleshooting

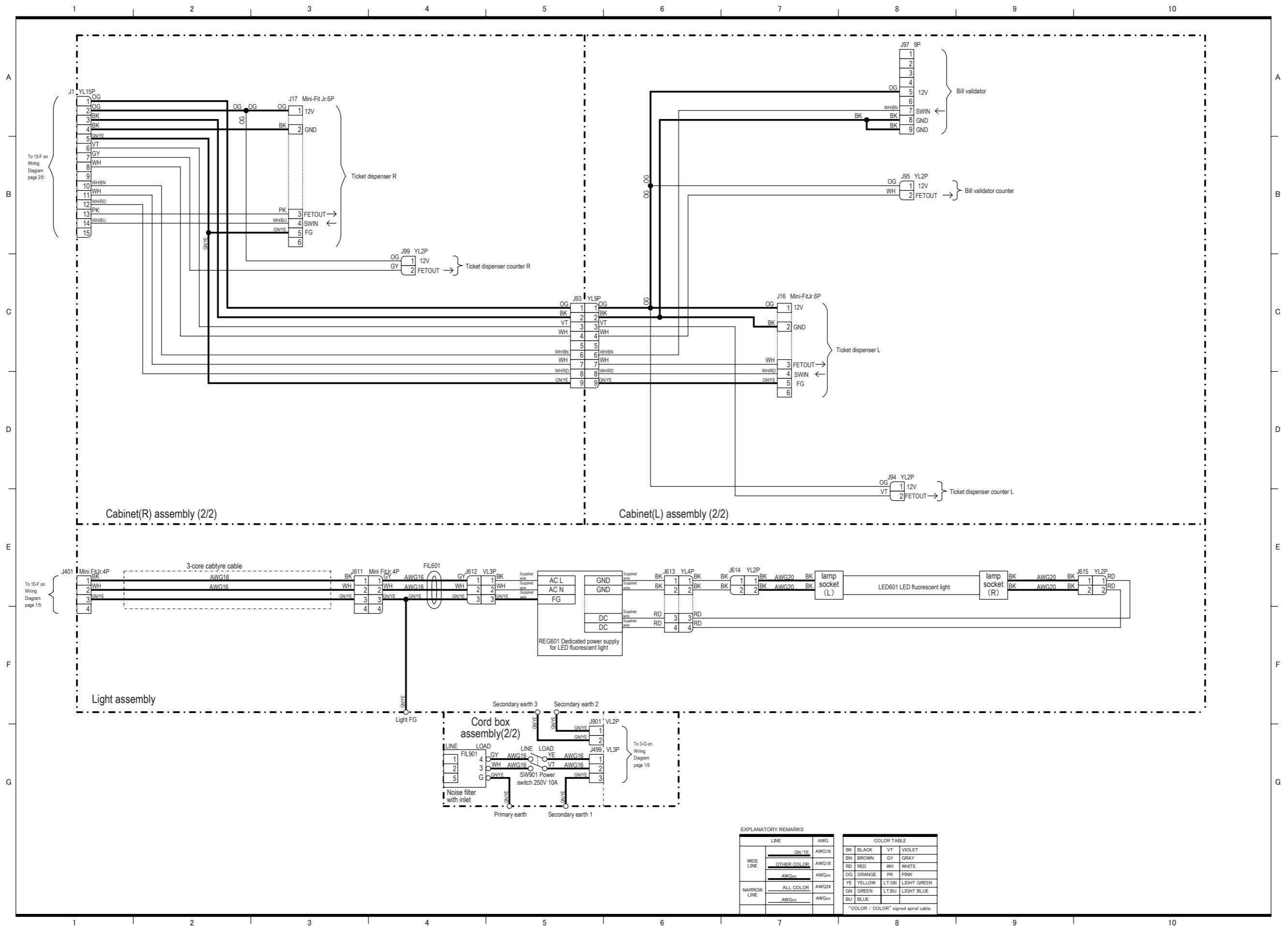

EXPLANATORY REMARKS

LINE	AWG	COLOR TABLE
WIDE LINE	GN/YE	AWG16
	OTHER COLOR	AWG18
	AWGxx	AWGxx
NARROW LINE	ALL COLOR	AWG24
	AWGxx	AWGxx
	"COLOR / COLOR" signed spiral cable.	

- 1
- 2
- 3
- 4
- 5
- 6
- 7
- 8A
- 8B
- 9
- 10
- 11
- 12

Wiring Diagram

Test Mode

Troubleshooting

© NAMCO BANDAI Games Inc.

Part No.: 731-695
First edition issued
December 2012